

STORA LISTAN



SWEBOLT AB

Tel: 08 - 584 909 60 Fax: 08 - 583 581 82

SWEBOLT AB

Järfälla

SWEBOLT AB

BOX 2029 176 02 Järfälla

Tel: 08 - 555 975 00

Fax: 08 - 583 581 82

E-mail: info@swebolt.se

Norrköping

Anders Kellerman

Tel: 08 - 555 975 10

Skåne

Ulf Qvist

Tel: 040 - 606 10 01

Stockholm Norr

Dag Ericsson

Tel: 08 - 555 975 11

Stockholm Syd

Joakim Oxelvik

Tel: 08 - 555 975 12

Tranås

SWEBOLT Tranås AB

BOX 60 573 21 Tranås

Tel: 0140 - 36 23 00

Fax: 0140 - 74 13 54

Mail: tranas@swebolt.se

Håkan Jonsson

Tel: 0140 - 36 23 01

Fredrik Axelsson

Tel: 0140 - 36 23 03

1. SEXKANTSKRUV

2. INSEXSKRUV

3. MUTTER

4. BRICKOR

5. LÅSRINGAR

6. GÄNGSTÅNG, PINNSKRUV

7. SPÅRSKRUV

8. PLÅTSKRUV

9. TRÄSKRUV, UNIVERSALSKRUV

10. ÖVRIGA SKALLFORMER

11. PINNAR, RÖRPROPPAR

12. KILAR, VAJERLÅS

13. NIT, BLINDNIT

14. SAXPINNAR, LÅSNÅLAR

15. BYGGPRODUKTER

16. MÖBEL, BESLAG

17. GÄNGINSATSER, DISTANSER

18. VERKTYG

Leveransvillkor

SWEBOLT AB levererar gods enligt de allmänna bestämmelserna i NLS 95.

- Priser: Samtliga priser i gällande prislista är exklusive moms, mervärdesskatt. Priserna är skrivna som brutto SEK per 100 stycken om inte annat anges.
- Betalningsvillkor: Betalningstid 30 dagar netto från fakturadatum. Därefter debiteras dröjsmålsränta. Vid sen betalning debiteras påminnelseavgift och ränta. Avvikelse i leverans och/eller levererat gods skall skriftligen meddelas leverantören inom 7 dagar.
- Frakter: Samtliga priser i aktuell prislista gäller fritt vårt lager i Järfälla. Expressleveranser debiteras enligt överenskomet per tillfälle. Leveranser inom Stor Stockholm levereras med anlitat transportföretag och debiteras enligt fraktavtal. Eventuella restleveranser levereras fraktfritt eller enligt överenskommelse.
- Förpackningar: Förpackningsstorlek anges per artikeltyp och sida. Avvikelse kan förekomma.
- Bruten förpackning: Priserna i aktuell prislista är baserade på hel förpackning. Bruten förpackning debiteras 30 kronor per artikelrad.
- Minorder: Minsta fakturabelopp är 500 kronor netto, exkl. frakt och emballage. Gäller ej eventuella restleveranser.
- Emballage: Debiteras till självkostnad.
- Retur av gods: Godkännes endast med bifogad kopia på vår följesedel och godkännande av oss. Kontakta oss för returinstruktion. Returer krediteras med 80% av debiterat pris.
- Annullering: Order kan endast annulleras enligt överenskommelse med oss. Annullering av specialbeställda artiklar kan inte accepteras.
- Certifikat: Certifikat och intyg debiteras till självkostnad, för närvarande 75 kronor. Gäller lagerförda artiklar och intyg/certifikat beställda vid ordertillfället. Övriga certifikat debiteras enligt överenskomet.
- Tryckfel: **SWEBOLT AB** ansvarar inte för följderna orsakat av eventuella tryckfel i aktuell prislista.

SWEBOLT AB

TEL 08 – 584 909 60 FAX 08 – 583 581 82

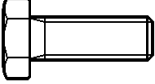
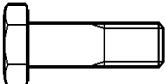
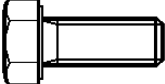
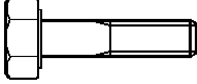
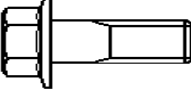
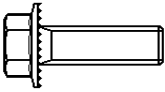
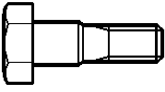
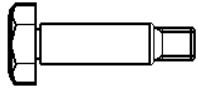
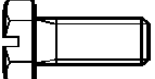
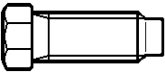
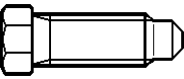
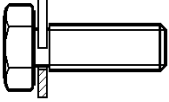
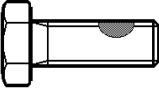
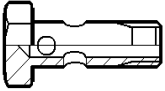
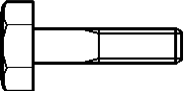
- 1 - 	- 2 - 	- 3 - 	- 4 - 
- 5 - 	- 6 - 	- 7 - 	- 8 - 
- 9 - 	- 10 - 	- 11 - 	- 12 - 
- 13 - 	- 14 - 	- 15 - 	- 16 -
- 17 -	- 18 -	- 19 -	- 20 -
- 21 -	- 22 -	- 23 -	- 24 -
- 25 -	- 26 -	- 27 -	- 28 -
- 29 -	- 30 -	- 31 -	- 32 -

SWEBOLT AB

TEL. 08-584 909 60 FAX. 08-583 581 82

PRODUKTER I STÅL

1	11101	M6SH, 6-KANT, HELGÄNGA	558	4018	5.8	OBEH	1:39
1	11102	M6SH, 6-KANT, HELGÄNGA	558	4018	5.8	FZB	1:39
2	11105	M6S, 6-KANT, HELGÄNGA	601	4016	4.6-6.8	OBEH	1:40
2	11106	M6S, 6-KANT, DELGÄNGA	601	4016	4.6-6.8	FZB	1:41
2	11107	M6S, 6-KANT, DELGÄNGA	601		4.6	FZV	1:42
4	11110	M6S, 6-KANT, DELGÄNGA		4014	8.8	OBEH	1:1
4	11111	M6S, 6-KANT, DELGÄNGA		4014	8.8	FZB	1: 4
4	11111	M6S, 6-KANT, DELGÄNGA		4014	8.8	DEPO	1: 102
4	11112	M6S, 6-KANT, DELGÄNGA		4014	8.8	FZV	1:9
4	11113	M6S, 6-KANT, DELGÄNGA	931		8.8	OBEH	1:3
4	11114	M6S, 6-KANT, DELGÄNGA	931		8.8	FZB	1:7
4	11114	M6S, 6-KANT, DELGÄNGA	931		8.8	DEPO	1:102
4	11115	M6S, 6-KANT, DELGÄNGA	931		8.8	FZV	1:10
4	11130	M6S, 6-KANT, DELGÄNGA		4014	10.9	OBEH	1:13
4	71131	M6S, 6-KANT, DELGÄNGA		4014	10.9	FZB/DEPO	1:106
4	11116	M6S, 6-KANT, DELGÄNGA	931		10.9	OBEH	1:13
4	71117	M6S, 6-KANT, DELGÄNGA	931		10.9	FZB/DEPO	1:106
4	11118	M6S, 6-KANT, DELGÄNGA	931		12.9	OBEH	1:20
4	11119	M6S, 6-KANT, DELGÄNGA		4014	12.9	OBEH	1:20
3	11120	M6SH, 6-KANT, HELGÄNGA		4017	8.8	OBEH	1:1
3	11121	M6SH, 6-KANT, HELGÄNGA		4017	8.8	FZB	1:5
3	71121	M6SH, 6-KANT, HELGÄNGA	933		8.8	DEPO	1:100
3	11122	M6SH, 6-KANT, HELGÄNGA		4017	8.8	FZV	1:9
3	11123	M6SH, 6-KANT, HELGÄNGA	933		8.8	OBEH	1:5
3	11124	M6SH, 6-KANT, HELGÄNGA	933		8.8	FZB	1:7
3	11125	M6SH, 6-KANT, HELGÄNGA	933		8.8	FZV	1:9
3	11126	M6SH, 6-KANT, HELGÄNGA	933		10.9	OBEH	1:11
3	71127	M6SH, 6-KANT, HELGÄNGA	933		10.9	FZB/DEPO	1:104
3	11132	M6SH, 6-KANT, HELGÄNGA		4017	10.9	OBEH	1:11
3	71133	UDDA LÄNGDER, 6-KANT, HELG.		4017	10.9	FZB/DEPO	1:104
3	11128	M6SH, 6-KANT, HELGÄNGA	933		12.9	OBEH	1:19
3	11129	M6SH, 6-KANT, HELGÄNGA		4017	12.9	OBEH	1:19
4	11134	FM6S, 6-KANT, DEL/ FINGÄNGA		8765	10.9	OBEH	1:13
4	71135	FM6S, 6-KANT, DELGÄNGA		8765	10.9	FZB/DEPO	17:18
3	11136	FM6SH, 6-KANT, DEL/ FINGÄNGA	960		10.9	OBEH	1:28
4	71137	FM6S, 6-KANT, DEL/ FINGÄNGA	960		10.9	FZB/DEPO	1:111
3	11138	FM6SH, 6-KANT, HELGÄNGA	961		12.9	OBEH	1:19
4	11139	FM6S, 6-KANT, DELGÄNGA	960		12.9	OBEH	1:20

BILD	ART.GR.	BENÄMNING	DIN	ISO	KVAL	YTBEH	SIDA
3	11140	FM6S, DELG., FINGÄNGAD		8765	8.8	OBEH	1:24
3	11141	FM6S, DELG., FINGÄNGAD		8765	8.8	FZB	1:26
4	11142	FM6S, DEL/ FINGÄNGAD	960		8.8	OBEH	1:24
4	11143	FM6S, DEL/ FINGÄNGAD	960		8.8	FZB	1:26
3	11144	FM6SH, HEL/ FINGÄNGAD		8676	10.9	OBEH	1:27
3	71145	FM6SH, FINGÄNGAD	8676		10.9	FZB/DEPO	1:110
3	11146	FM6SH, HEL/FINGÄNGAD	(961)		10.9	OBEH	1:27
4	71147	FM6S, HEL/ FINGÄNGAD	961		10.9	FZB/DEPO	1:110
	11148	FM6SH, HEL/ FINGÄNGAD		8676	12.9	OBEH	1:29
	11149	FM6S, DEL/FINGÄNGAD		8765	12.9	OBEH	1:30
3	11150	FM6SH, HELGÄNGA FINGÄNGA		8676	8.8	OBEH	1:23
3	11151	FM6SH, HELGÄNGA FINGÄNGA		8676	8.8	FZB	1:25
4	11152	FM6SH, HELGÄNGA FINGÄNGA		961	8.8	OBEH	1:23
4	11153	FM6SH, HELGÄNGA FINGÄNGA		961	8.8	FZB	1:25
3-4	11155	U6S, UNC-GÄNGA	B 18.2.1		8.8	OBEH	1:59
3-4	11156	U6S, UNC-GÄNGA	B 18.2.1		8.8	FZB	1:60
3-4	11157	U6S, UNC-GÄNGA	B 18.2.1		8.8	FZV	1:61
3-4	11158	U6S, UNC-GÄNGA	B 18.2.1		10.9	OBEH	1:62
3-4	11160	FU6S, UNF-GÄNGA, FINGÄNGAD	B 18.2.1		8.8	OBEH	1:63
3-4	11161	FU6S, UNF-GÄNGA, FINGÄNGAD	B 18.2.1		8.8	FZB	1:64
3-4	11163	FU6S, UNF-GÄNGA, FINGÄNGAD			10.9	OBEH	1:65
3-4	11165	W6S, WITHWORTH GÄNGAD			8.8	OBEH	1:66
3-4	11168	BSF-SAE OCH ANDRA GÄNGOR PÅ BEGÄRAN					
5	11170	M6SF, 6-KANT MED FLÄNS	6921		8.8	OBEH	1:31
5	11171	M6SF, 6-KANT MED FLÄNS	6921		8.8	FZB	1:32
5	11172	M6SF, 6-KANT MED FLÄNS	6921		10.9	OBEH	1:33
5	71173	M6SF, 6-KANT MED FLÄNS	6921		10.9	FZB/DEPO	1:112
5	11174	FM6SF, 6-KANT MED FLÄNS, FING.			8.8	OBEH	1:34
5	11175	FM6SF, 6-KANT MED FLÄNS, FING.			8.8	FZB	1:35
	11176	FM6SF	6921		8.8	FZG	
6	11180	M6SFT, RÄFFLAD 6-KANTSKRUV			8.8	OBEH	1:37
6	11181	M6SFT, RÄFFLAD 6-KANTSKRUV			8.8	FZB	1:38
	11182	M6SFT, RÄFFLAD 6-KANTSKRUV	KL. 90			OBEH	1:39
	11183	M6SFT, RÄFFLAD 6-KANTSKRUV	KL. 100			OBEH	1:40
6	11200	M6SPB, 6-KANT, PASSNING h11	7968		5.6	OBEH	1:47
7	11190	M6SPBK, K6, LÅNG GÄNGA	609		8.8	OBEH	1:57
7	11191	M6SBBL, K6, KORT GÄNGA	610		8.8	OBEH	1:58
8	11193	SBL, STÅLLBYGGNANDBULT	7990		4.6-5.6	OBEH	1:48
8	11194	SBL, STÅLLBYGGNADSBULT	7990		4.6-5.6	FZB	1:49
8	11195	SBL, STÅLLBYGGNADSBULT	7990		4.6-5.6	FZV	1:50
9	11250	M6SHSZ, 6-KANT+MEJSELSPÅR	933SZ		5.8	OBEH	1:51
9	11251	M6SHSZ, 6-KANT+MEJSELSPÅR	933SZ		5.8	FZB	1:51

SWEBOLT AB

TEL. 08-584 909 60 FAX. 08-583 581 82

BILD	ART.GR.	BENÄMNING	DIN	ISO	KVAL	YTBEH	SIDA
10	11260	M6STG, TAPP OCH GÄNGA	561A		8.8	OBEH	1:52
10	11261	M6STG, TAPP OCH GÄNGA	561A		8.8	FZB	1:52
11	11266	M6ST, TAPP	564B		8.8	OBEH	1:53
11	11267	M6ST, TAPP	564B		8.8	FZB	1:53
12	11290	M6SOB, 6-KANT + BRICKA	6900				1:54
13	11300	M6S - ESLOK YTBHANDLING ENL ÖNSKEMÅL					1:66
13	11301	M6S - DRYLOC YTBHANDLING ENL ÖNSKEMÅL					1:66
13	11302	M6S - DRYSEAL YTBHANDLING ENL ÖNSKEMÅL					1:66
13	11303	M6S - PRICOTE 5 YTBHANDLING ENL ÖNSKEMÅL					1:66
14	11320	6HS, HÅLSKRUV	7623A			OBEH	1:55
14	11321	6HS, HÅLSKRUV, 2-VÄGS	7623C			OBEH	1:56
15	11291	SB, STÅLBYGGNADSBULT			8.8	FZV	1:43
15	11295	HSB, STÅLBYGGNADSBULT	6914	7412	10.9	OBEH	1:44
15	11296	HSB, STÅLBYGGNADSBULT	6914	7412	10.9	FZB	1:45
15	11297	HSB, STÅLBYGGNADSBULT	6914	7412	10.9	FZV	1:46
	11330	UHM6S, VARMHÅLLFAST				OBEH	

ROSTFRITT / SYRAFAST

4	21110	M6S, ROSTFRI, DELGÄNGA		4014	A2		1:72
4	21111	M6S, SYRAFAST, DELGÄNGA		4014	A4		1:75
4	21112	M6S, SYRAFAST, DELGÄNGA		4014	A4-80		1:74
4	21210	M6S, ROSTFRI, DELGÄNGA		4014	A2	FZB	1:78
4	21211	M6S, SYRAFAST, DELGÄNGA		4014	A4-80	FZB	1:80
4	21212	M6S, SYRAFAST, DELGÄNGA		4014	A4	8.8 BUMAX	1:82
4	21113	M6S, ROSTFRI DELGÄNGA	931		A2		1:72
4	21114	M6S, SYRAFAST, DELGÄNGA	931		A4		1:75
4	21115	M6S, SYRAFAST, DELGÄNGA	931		A4-80		1:73
4	21213	M6S, ROSTFRI, DELGÄNGA	931		A2	FZB	1:78
4	21214	M6S, SYRAFAST, DELGÄNGA	931		A4-80	FZB	1:80
3	21120	M6SH, ROSTFRI HELGÄNGA		4017	A2		1:71
3	21121	M6SH, SYRAFAST, HELGÄNGA		4017	A4		1:75
3	21122	M6SH, SYRAFAST, HELGÄNGA		4017	A4-80		1:73
3	21220	M6SH, ROSTFRI, HELGÄNGA		4017	A2	FZB	1:77
3	21221	M6SH, SYRAFAST, HELGÄNGA		4017	A4-80	FZB	1:79
3	21222	M6SH, SYRAFAST HELGÄNGA		4017	A4-8.8	BUMAX	1:81
3	21123	M6SH ROSTFRI, HELGÄNGA	933		A2		1:71
3	21124	M6SH, SYRAFAST, HELGÄNGA	933		A4		1:75
3	21125	M6SH, SYRAFAST, HELGÄNGA	933		A4-80		1:73
3	21223	M6SH, ROSTFRI, HELGÄNGA	933		A2	FZB	1:77
3	21224	M6SH, SYRAFAST, HELGÄNGA	933		A4-80	FZB	1:79
4	21140	FM6S, ROSTFRI, DELG-FING.		8765	A2		1:86
4	21141	FM6S, SYRAFAST, DELG FING		8765	A4		1:88
4	21142	FM6S, ROSTFRI DELG-FING.	960		A2		1:86
4	21143	FM6S, SYRAFAST DELG-FING.	960		A4		1:88

SWEBOLT AB

TEL. 08-584 909 60 FAX. 08-583 581 82

BILD	ART.GR.	BENÄMNING	DIN	ISO	KVAL	YTBEH	SIDA
3	21150	FM6SH, ROSTFRI HELG-FING.		8676	A2		1:85
3	21151	FM6SH, SYRAFAST, HELG-FING.		8676	A4		1:87
3	21152	FM6SH, ROSTFRI, HELG-FING.	961		A2		1:85
3	21153	FM6SH, SYRAFAST, HELG-FING.	961		A4		1:87
3-4	21155	U6S, 6-KANT, UNC-GÄNGA	UNC		A2		1:77
3-4	21156	U6S, 6-KANT, UNC-GÄNGA	UNC		A4		1:77
3-4	21160	FU6S, 6-KANT, UNF-GÄNGA	UNF		A2		1:78
3-4	21161	FU6S, 6-KANT, UNGF-GÄNGA	UNF		A4		1:78
5	21170	M6SF, 6-KANT M. FLÄNS	6921		A2		1:89
5	21171	M6SF, 6-KANT M. FLÄNS	6921		A4		1:90
3	21250	M6SH SZ 6-KANT+MEJSELSPÅR	933SZ		A2		1:91
3	21251	M6SH SZ 6-KANT+MEJSELSPÅR	933SZ		A4		1:92
12	21290	M6SOB, 6-KANT + OF.BRICKA	6900		A4		1:80
3	21138	M6SH, 6-KANT, HELGÄNGA	933	4017	DUPLEX		
4	21137	M6S, 6-KANT, DELGÄNGA	931	4014	DUPLEX		

MÄSSING

3	31120	M6SH, 6-KANT, HELGÄNGA	933	4017			1:20
4	31110	M6S, 6-KANT, DELGÄNGA	931	4014			1:23
3	31121	M6SH, 6-KANT, HELGÄNGA	933	4017		FÖRNICKLAD	1:22
4	31111	M6S, 6-KANT, DELGÄNGA	931	4014		FÖRNICKLAD	1:23
9	31250	M6SHSZ, 6-KANT+MEJSELSPÅR	933SZ				1:22

POLYAMID

3	41120	M6SH, 6-KANT, HELGÄNGA	933	4017			1:30
4	41110	M6S, 6-KANT, DELGÄNGA	931	4014			1:31

KOPPAR

3	51120	M6SH, 6-KANT, HELGÄNGA	933	4017			1:40
---	-------	------------------------	-----	------	--	--	------

ALUMINIUM

3	61120	M6SH, 6-KANT, HELGÄNGA	933	4017			1:50
---	-------	------------------------	-----	------	--	--	------

TITAN

3	71120	M6SH, 6-KANT, HELGÄNGA	933	4017			1:60
---	-------	------------------------	-----	------	--	--	------

SWEBOLT AB

TEL. 08-584 909 60 FAX. 08-583 581 82

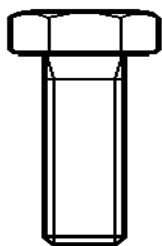

ARTIKELLISTA

2013-2014

HELGÄNGAD SEXKANTSKRUV

M6SH 8.8 ISO 4017 / DIN 933

OBEHANDLAD

		ISO	DIN	ISO	DIN	ISO	DIN	ISO	DIN				
GÄNGA	M4	M5	M6	M8	M10	M10	M12	M12	M14	M14	M16	M18	M20
Nyckelv	7	8	10	13	16	17	18	19	21	22	24	27	30
Skallh	2.8	3.5	4	5.3	6.4	6.4	7.5	7.5	8.8	8.8	10	11.5	12.5
Längd	C:A PRIS / 100 ST												
8	X	X	X										
10	X	X	X										
12	X	X	X	X									
14	X	X	X	X									
16	X	X	X	X	X	X							
20	X	X	X	X	X	X	X		X	X	X		
22	X	X	X	X	X	X	X						
25	X	X	X	X	X	X	X	X	X		X		
30	X	X	X	X	X	X	X	X	X	X	X	X	
35	X	X	X	X	X	X	X	X	X	X	X	X	X
40	X	X	X	X	X	X	X	X	X	X	X	X	X
45	X	X	X	X	X	X	X	X	X	X	X	X	X
50	X	X	X	X	X	X	X	X	X	X	X	X	X
55		X	X	X	X	X	X	X	X	X	X	X	X
60		X	X	X	X	X	X	X	X	X	X	X	X
65				X	X	X	X	X	X	X	X	X	X
70				X	X	X	X	X	X	X	X	X	X
75				X	X	X	X	X	X	X	X	X	X
80				X	X	X	X	X	X	X	X	X	X
90				X		X	X	X		X	X	X	X
100				X		X	X	X		X	X	X	X
110				X		X		X		X	X	X	X
120				X		X		X		X	X	X	X
130				X		X		X		X	X	X	X
140				X	X	X		X		X	X	X	X
150				X		X		X		X	X	X	X
160				X		X		X		X	X	X	X
180				X		X		X		X	X	X	X
200				X		X		X		X	X	X	X
220				X		X		X		X	X	X	X
240				X		X		X		X	X	X	X
260				X		X		X		X	X	X	X
280				X		X		X		X	X	X	X

KRYSSMARKERADE ARTIKLAR MOT FÖRFRÅGAN !

FÖRP.	M4	M5	M6	M8	M10	M10	M12	M12	M14	M14	M16	M18	M20
500 ST	8-	8-	8-										
200 ST			20-			16-							
100 ST				10-		40-	20-	20-		20-			
50 ST				100-		110-	75-	35-		50-	20-		
25 ST							150-	100-		120-	50-	30-	30-
10 ST												120-	160-
5 ST												220-	220-
1 ST													280-

BESTÄLLNINGSEXEMPEL ISO: 1112010060 = M6SH M10x60 8.8 OBEH ISO 4017

BESTÄLLNINGSEXEMPEL DIN: 1112310060 = M6SH M10x60 8.8 OBEH DIN 933

SWEBOLT AB

TEL 08 - 555 975 00 FAX 08 - 583 581 82

ARTIKELLISTA
2013-2014
HELGÄNGAD SEXKANTSKRUV
M6SH 8.8 ISO 4017 / DIN 933
OBEHANDLAD

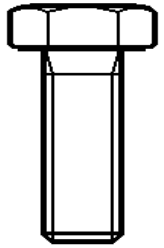

GÄNGA	DIN									
	M22	M24	M27	M30	M33	M36	M39	M42	M45	M48
Nyckelv	32	36	41	46	50	55	60	65	70	75
Skallh	14	15	17	18.7	21	22.5	25	26	28	30
Längd	C:A PRIS / 100 ST									
40	X	X								
45	X	X								
50	X	X	X	X	X	X				
55	X	X	X	X	X	X				
60	X	X	X	X	X	X				
65	X	X	X	X	X	X	X			
70	X	X	X	X	X	X	X	X		
75	X	X	X	X	X	X	X	X		
80	X	X	X	X	X	X	X	X	X	X
90	X	X	X	X	X	X	X	X	X	X
100	X	X	X	X	X	X	X	X	X	X
110	X	X	X	X	X	X	X	X	X	X
120	X	X	X	X	X	X	X	X	X	X
130	X	X	X	X	X	X	X	X	X	X
140	X	X	X	X	X	X	X	X	X	X
150	X	X	X	X	X	X	X	X	X	X
160	X	X	X	X	X	X	X	X	X	X
180	X	X	X	X	X	X	X	X	X	X
200	X	X	X	X	X	X	X	X	X	X
220	X	X	X	X	X	X	X	X	X	X
240	X	X	X	X	X	X	X	X	X	X
260	X	X	X	X	X	X	X	X	X	X
280	X	X	X	X	X	X	X	X	X	X
300	X	X	X	X	X	X	X	X	X	X
320	X	X	X	X	X	X	X	X	X	X
340	X	X	X	X	X	X	X	X	X	X
360	X	X	X	X	X	X	X	X	X	X
380	X	X	X	X	X	X	X	X	X	X
400	X	X	X	X	X	X	X	X	X	X
420	X	X	X	X	X	X	X	X	X	X

KRYSSMARKERADE ARTIKLAR MOT FÖRFRÅGAN !

FÖRP.	M22	M24	M27	M30	M33	M36	M39	M42	M45	M48
25 ST	40-	40-								
10 ST	100-	90-	50-	50-	50-	50-	80-			
5 ST	200-	200-	200-	200-	200-	200-	200-	80-	80-	80-
1 ST	260-	260-	260-	260-	260-	260-	260-	200-	200-	200-

BESTÄLLNINGSEXEMPEL ISO: 1112024050 = M6SH M24x50 8.8 OBEH ISO 4017

BESTÄLLNINGSEXEMPEL DIN: 1112322080 = M6SH M22x65 8.8 OBEH DIN 933

SWEBOLT AB

TEL 08 - 555 975 00 FAX 08 - 583 581 82

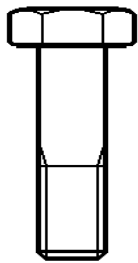

ARTIKELLISTA
2013-2014
DELGÄNGAD SEXKANTSKRUV
M6S 8.8 ISO 4014 / DIN 931
OBEHANDLAD

GÄNGA				ISO	DIN	ISO	DIN	ISO	DIN				DIN		
	M5	M6	M8	M10	M10	M12	M12	M14	M14	M16	M18	M20	M22	M24	
Nyckelv	8	10	13	16	17	18	19	21	22	24	27	30	32	36	
Skallhöjd	3.5	4	5,3	6.4	6.4	7.5	7.5	8.8	8.8	10	11.5	12.5	14	15	
Gängl	16	18	22	26	26	30	30	34	34	38	42	46	50	54	
120-			26	32	32	36	36	40	40	44	48	52	56	60	
200-				45	45	49	49	53	53	57	61	65		73	
Längd	C:A PRIS / 100 ST														
30	X	X													
35	X	X	X												
40	X	X	X	X	X										
45	X	X	X	X	X		X								
50	X	X	X	X	X	X	X	X	X						
55	X	X	X	X	X	X	X	X	X	X					
60	X	X	X	X	X	X	X	X	X	X	X				
65	X	X	X	X	X	X	X	X	X	X	X	X			
70	X	X	X	X	X	X	X	X	X	X	X	X	X		
75	X	X	X	X	X	X	X	X	X	X	X	X	X	X	
80	X	X	X	X	X	X	X	X	X	X	X	X	X	X	
90	X	X	X	X	X	X	X	X	X	X	X	X	X	X	
100	X	X	X	X	X	X	X	X	X	X	X	X	X	X	
110		X	X	X	X	X	X	X	X	X	X	X	X	X	
120		X	X	X	X	X	X	X	X	X	X	X	X	X	
130		X	X	X	X	X	X	X	X	X	X	X	X	X	
140		X	X	X	X	X	X	X	X	X	X	X	X	X	
150		X	X	X	X	X	X	X	X	X	X	X	X	X	
160		X	X	X	X	X	X	X	X	X	X	X	X	X	
180			X	X	X	X	X	X	X	X	X	X	X	X	
200			X	X	X	X	X	X	X	X	X	X	X	X	
220			X	X	X	X	X	X	X	X	X	X	X	X	
240			X		X		X		X	X	X	X	X	X	
250														X	
260			X		X		X		X	X	X	X	X	X	
280			X		X		X		X	X	X	X	X	X	
300			X		X		X		X	X	X	X	X	X	
320					X		X		X	X	X	X	X	X	
340					X		X		X	X	X	X	X	X	
360					X		X		X	X	X	X	X	X	
380					X		X		X	X	X	X	X	X	
400					X		X		X	X	X	X	X	X	
420					X		X		X	X	X	X	X	X	
440					X		X		X	X	X	X	X	X	
460					X		X		X	X	X	X	X	X	
480					X		X		X	X	X	X	X	X	
500					X		X		X	X	X	X	X	X	

KRYSSMARKERADE ARTIKLAR MOT FÖRFRÅGAN !

FORP.	M5	M6	M8	M10	M10	M12	M12	M14	M14	M16	M18	M20	M22	M24
200 ST		30-												
100 ST			40-	40-	40-									
50 ST			110-	100-	100-	45-	45-	50-	50-					
25 ST				200-	200-	100-	160-	140-	140-	55-		70-	70-	80-
10 ST										70-	60-	100-	100-	100-
5 ST										200-	200-	200-	200-	200-
1 ST												320-	320-	320-

BESTÄLLNINGSEXEMPEL ISO: 1111010060 = M6S M10x60 8.8 OBEH ISO 4014

BESTÄLLNINGSEXEMPEL DIN: 1111310060 = M6S M10x60 8.8 OBEH DIN 931

SWEBOLT AB

TEL 08 - 584 909 60 FAX 08 - 583 581 82

ARTIKELLISTA
2013-2014
DELGÄNGAD SEXKANTSKRUV
M6S 8.8 ISO 4014 / DIN 931
OBEHANDLAD

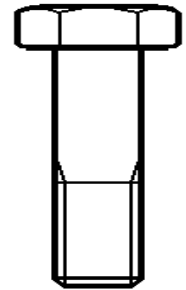

GÄNGA	M27	M30	M33	M36	M39	M42	M45	M48
Nyckelv	41	46	50	55	60	65	70	75
Skallhöjd	17	18.7	21	22.5	25	26	28	30
Gängl	60	66	72	78	84	90	96	102
120-	66	72	78	84	90	96	102	108
200-	79	85	95	97	103	109	115	121
Längd	C:A PRIS / 100 ST							
80	X	X						
90	X	X						
100	X	X	X					
110	X	X	X	X				
120	X	X	X	X	X	X		
130	X	X	X	X	X	X	X	
140	X	X	X	X	X	X	X	X
150	X	X	X	X	X	X	X	X
160	X	X	X	X	X	X	X	X
180	X	X	X	X	X	X	X	X
200	X	X	X	X	X	X	X	X
220	X	X	X	X	X	X	X	X
240	X	X	X	X	X	X	X	X
260	X	X	X	X	X	X	X	X
280	X	X	X	X	X	X	X	X
300	X	X	X	X	X	X	X	X
320	X	X	X	X	X	X	X	X
340	X	X	X	X	X	X	X	X
360	X	X	X	X	X	X	X	X
380	X	X	X	X	X	X	X	X
400	X	X	X	X	X	X	X	X
420	X	X	X	X	X	X	X	X
440	X	X	X	X	X	X	X	X
460	X	X	X	X	X	X	X	X
480	X	X	X	X	X	X	X	X
500	X	X	X	X	X	X	X	X
520	X	X	X	X	X	X	X	X
540	X	X	X	X	X	X	X	X
560	X	X	X	X	X	X	X	X
580	X	X	X	X	X	X	X	X
600	X	X	X	X	X	X	X	X

KRYSSMARKERADE ARTIKLAR MOT FÖRFRÅGAN !

FÖRP.	M27	M30	M33	M36	M39	M42	M45	M48
10 ST	80-	80-	100-					
5 ST	160-	160-	150-	110-				
1 ST	300-	300-	300-	240-	120-	120-	130-	140-

BESTÄLLNINGSEXEMPEL: 1111036160 = M6S M36x160 8.8 OBEH ISO 4014

SWEBOLT AB
TEL 08 - 555 975 00 FAX 08 - 583 581 82

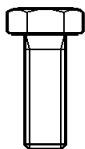

ARTIKELLISTA

2013-2014

HELGÄNGAD SEXKANTSKRUV M6SH 8.8 FZB ISO 4017 / DIN 933 BLANKFÖRZINKAD



						ISO	DIN	ISO	DIN	ISO	DIN	
GÄNGA	M3	M4	M5	M6	M8	M10	M10	M12	M12	M14	M14	M16
Nyckelv	5.5	7	8	10	13	16	17	18	19	21	22	24
Skallh	2	2.8	3.5	4	5.3	6.4	6.4	7.5	7.5	8.8	8.8	10
Längd	C:A PRIS/100 ST											
6	X	X	X									
8	X	X	X	X								
10	X	X	X	X	X							
12	X	X	X	X	X	X	X					
14	X	X	X	X	X	X	X					
16	X	X	X	X	X	X	X	X	X			
18			X	X	X	X	X		X			
20	X	X	X	X	X	X	X	X	X	X	X	X
22	X	X	X	X	X	X	X		X			
25	X	X	X	X	X	X	X	X	X	X	X	X
30		X	X	X	X	X	X	X	X	X	X	X
35		X	X	X	X	X	X	X	X	X	X	X
40		X	X	X	X	X	X	X	X	X	X	X
45		X	X	X	X	X	X	X	X	X	X	X
50		X	X	X	X	X	X	X	X	X	X	X
55			X	X	X	X	X	X	X	X	X	X
60			X	X	X	X	X	X	X	X	X	X
65			X	X	X	X	X	X	X		X	X
70			X	X	X	X	X	X	X		X	X
75			X	X	X	X	X	X	X		X	X
80			X	X	X	X	X	X	X	X	X	X
90			X	X	X		X	X	X		X	X
100			X	X	X		X	X	X		X	X
110				X	X		X		X		X	X
120				X	X		X		X		X	X
130				X	X		X		X		X	X
140				X	X		X		X		X	X
150				X	X		X		X		X	X
160					X		X	X	X			X
180					X		X		X			X
200					X		X		X			X
220									X			X
240									X			X
260												X
280												X
300												X

KRYSSMARKERADE ARTIKLAR MOT FÖRFRÅGAN !
ÖVRIGA DIMENSIONER OCH LÄNGDER MOT FÖRFRÅGAN !

FÖRP.	M3	M4	M5	M6	M8	M10	M10	M12	M12	M14	M14	M16
500 ST												
200 ST		8-	8-	8-								
100 ST				90-	10-	12-	12-	16-	16-			
50 ST					140-	70-	70-	35-	35-	20-	20-	20-
25 ST								100-	100-	75-	75-	40-
10 ST										110-	110-	110-

BESTÄLLNINGSEXEMPEL ISO: 1112110020 - M6SH M10x20 8.8 FZB ISO 4014

BESTÄLLNINGSEXEMPEL DIN: 1112410020 - M6SH M10x20 8.8 FZB DIN 933

SWEBOLT AB

TEL 08 - 555 975 00 FAX 08 - 583 581 82



ARTIKELLISTA

2013-2014

HELGÄNGAD SEXKANTSKRUV M6SH 8.8 FZB ISO 4017 / DIN 933 BLANKFÖRZINKAD

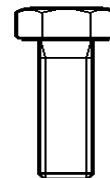

GÄNGA	DIN							
	M18	M20	M22	M24	M27	M30	M33	M36
Nyckelv	27	30	32	36	41	46	50	55
Skallh	11.5	12.5	14	15	17	18.7	21	22.5
Längd	C:A PRIS / 100 ST							
25		X						
30	X	X		X				
35	X	X		X				
40	X	X	X	X		X		
45	X	X	X	X		X		
50	X	X	X	X	X	X		X
55	X	X	X	X	X	X		
60	X	X	X	X	X	X	X	X
65	X	X	X	X	X	X		
70	X	X	X	X	X	X	X	X
75	X	X	X	X	X	X		
80	X	X	X	X	X	X	X	X
90		X	X	X	X	X	X	X
100		X	X	X	X	X	X	X
110		X	X	X	X	X	X	X
120		X	X	X	X	X	X	X
130		X		X	X	X	X	X
140		X		X	X	X	X	X
150		X		X	X	X	X	X
160		X		X	X	X	X	X
180		X		X	X	X		X
200		X		X	X	X		X
220		X		X		X		
240		X				X		
260		X				X		
280		X				X		
300		X				X		

KRYSSMARKERADE ARTIKLAR MOT FÖRFRÅGAN !
ÖVRIGA DIMENSIONER OCH LÄNGDER MOT FÖRFRÅGAN !

FÖRP.	M18	M20	M22	M24	M27	M30	M33	M36
25 ST	30-	30-	40-	35-				
10 ST	65-	65-	65-	45-	50-	50-		
5 ST		100-	100-	100-	100-	100-		
1 ST		240-	200-	160-	160-	140-	60-	50-

BESTÄLLNINGSEXEMPEL ISO: 1112120070 - M6SH M20x70 8.8 FZB ISO 4017
BESTÄLLNINGSEXEMPEL DIN: 1112422060 - M6SH M22x60 8.8 FZB DIN 933

FÖR M27 OCH GRÖVRE SE FZV PÅ SID 1:9

SWEBOLT AB

TEL 08 - 555 975 00 FAX 08 - 583 581 82

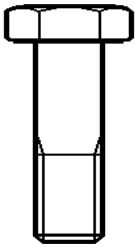

ARTIKELLISTA

2013-2014

DELGÄNGAD SEXKANTSKRUV M6S 8.8 FZB ISO 4014 / DIN 931 BLANKFÖRZINKAD



GÄNGA					ISO	DIN	ISO	DIN	ISO	DIN
	M4	M5	M6	M8	M10	M10	M12	M12	M14	M14
Nyckelh	7	8	10	13	16	17	18	19	21	22
Skallh	2.8	3.5	4	5.3	6.4	6.4	7.5	7.5	8.8	8.8
Gängl	14	16	18	22	26	26	30	30	34	34
125 ->					32	32	36	36	40	40
200 ->					45	45	49	49	53	53
Längd	C:A PRIS / 100ST									
30	X	X	X							
35	X	X	X	X						
40	X	X	X	X	X	X	X			
45	X	X	X	X	X	X	X	X		
50	X	X	X	X	X	X	X	X	X	X
55	X	X	X	X	X	X	X	X	X	X
60	X	X	X	X	X	X	X	X	X	X
65		X	X	X	X	X	X	X	X	X
70	X	X	X	X	X	X	X	X	X	X
75		X	X	X	X	X	X	X	X	X
80	X	X	X	X	X	X	X	X	X	X
90		X	X	X	X	X	X	X	X	X
100		X	X	X	X	X	X	X	X	X
110		x	X	X	X	X	X	X	X	X
120		x	X	X	X	X	X	X	X	X
130		X	X	X	X	X	X	X	X	X
140		X	X	X	X	X	X	X	X	X
150			X	X	X	X	X	X	X	X
160			X	X	X	X	X	X		X
180			X	X	X	X	X	X		X
200			X	X	X	X	X	X		X
220				X		X	X	X		X
240				X		X	X	X		X
260				X		X	X	X		X
280				X		X	X	X		X
300				X		X	X	X		X
320						X	X	X		X
340						X	X	X		X
360						X	X	X		X
380						X	X	X		X
400						X	X	X		X
420						X	X	X		X
440						X	X	X		X

KRYSSMARKERADE ARTIKLAR MOT FÖRFRÅGAN!
ÖVRIGA DIMENSIONER OCH LÄNGDER MOT LEVERANSTID OCH FÖRFRÅGAN!

FÖRP	M4	M5	M6	M8	M10	M10	M12	M12	M14	M14
200ST	35-	30-	30-							
100ST			70-	35-	40-	40-				
50ST				110-	60-	60-	45-	45-	50-	45-
25ST					120-	120-	100-	100-	70-	70-
10ST								220-		

BESTÄLLNINGSEXEMPEL ISO: 1111110080 - M6S M10x80 8.8 FZB ISO 4014
BESTÄLLNINGSEXEMPEL DIN: 1111410080 - M6S M10x80 4.6 FZB DIN 931

SWEBOLT AB

TEL 08 - 555 975 00 FAX 08 - 583 581 82

ARTIKELLISTA

2013-2014

DELGÄNGAD SEXKANTSKRUV M6S 8.8 FZB ISO 4014 / DIN 931 BLANKFÖRZINKAD

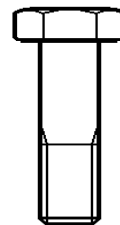

GÄNGA	ISO			DIN		M24	M27	M30
	M16	M18	M20	M22	M22			
Nyckelv	24	27	30	34	32	36	41	46
Skallh	10	11.5	12.5	14	14	15	17	18.7
Gängl	38	42	46	50	50	54	60	66
120 ->	44	48	52	56	56	60	66	72
200 ->	57	61	65	63	63	73	79	85
Längd	C:A PRIS / 100 ST							
55	X							
60	X	X						
65	X	X	X					
70	X	X	X		X			
75	X	X	X		X	X		
80	X	X	X		X	X		X
90	X	X	X		X	X	X	X
100	X	X	X		X	X	X	X
110	X	X	X		X	X	X	X
120	X	X	X		X	X	X	X
130	X	X	X		X	X	X	X
140	X	X	X		X	X	X	X
150	X	X	X		X	X	X	X
160	X	X	X		X	X	X	X
180	X	X	X		X	X	X	X
200	X	X	X		X	X	X	X
220	X	X	X		X	X	X	X
240	X	X	X		X	X	X	X
260	X	X	X		X	X	X	X
280	X	X	X		X	X	X	X
300	X	X	X		X	X	X	X
320	X	X	X		X	X	X	X
340	X	X	X		X	X	X	X
360	X	X	X		X	X	X	X
380	X	X	X		X	X	X	X
400	X	X	X		X	X	X	X
420	X	X	X			X	X	X
440	X	X	X			X	X	X
460	X	X	X			X	X	X
480	X	X	X			X	X	X
500	X	X	X			X	X	X

KRYSSMARKERADE ARTIKLAR MOT FÖRFRÅGAN!
ÖVRIGA DIMENSIONER OCH LÄNGDER MOT FÖRFRÅGAN!

FÖRP.	M16	M18	M20	M22	M22	M24	M27	M30
25 ST	60-	70-			75-			
10 ST	110-	80-	70-		80-	90-	80-	100-
1 ST	240-							

BESTÄLLNINGSEXEMPEL ISO: 1111120140 - M6S M20x140 8.8 FZB ISO 4014

BESTÄLLNINGSEXEMPEL DIN: 1111422090 - M6S M22x90 8.8 FZB DIN 931

FÖR M27 OCH GRÖVRE SE FZV PÅ SID 1:10

SWEBOLT AB

TEL 08 - 555 975 00 FAX 08 - 583 581 82

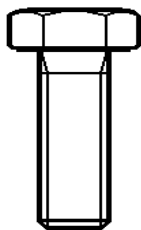

ARTIKELLISTA
2013-2014
HELGÄNGAD SEXKANTSKRUV
M6SH 8.8 FZV ISO 4017
VARMFÖRZINKAD



GÄNGA	M6	M8	M10	M12	M16	M18	M20	M22	M24	M27	M30	M33	M36
Nyckelv	10	13	16	18	24	27	30	34	36	41	46	50	55
Skallh	4	5.3	6.4	7.5	10	11.5	12.5	14	15	17	18.7	21	22.5
Längd	C:A PRIS/100 ST												
12	X	X	X										
16	X	X	X	X									
20	X	X	X	X	X								
25	X	X	X	X	X								
30	X	X	X	X	X		X						
35	X	X	X	X	X		X						
40	X	X	X	X	X	X	X		X				
45		X	X	X	X	X	X		X				
50		X	X	X	X	X	X	X	X	X			
55		X		X	X	X	X		X				
60		X	X	X	X	X	X	X	X	X	X		
65		X	X	X	X		X		X				
70		X	X	X	X		X	X	X	X	X		X
75		X	X	X			X		X				
80		X	X	X	X		X	X	X	X	X	X	X
90					X		X		X	X	X	X	X
100					X		X		X		X		X
110					X		X		X				
120					X		X		X		X		
130				X			X		X				
140							X		X				
150													

ÖVRIGA DIMENSIONER OCH LÄNGDER MOT FÖRFRÅGAN !

FÖRP.	M6	M8	M10	M12	M16	M18	M20	M22	M24	M27	M30	M33	M36
500 ST	12-												
200 ST	16-												
100 ST		12-	16-	16-									
50 ST			70-	35-	25-								
25 ST					40-	40-	30-	50-					
10 ST					100-		65-		40-	50-	70-	80-	
5 ST													70-

BESTÄLLNINGSEXEMPEL: 1112216060 - M6SH M16x60 8.8 FZV

SWEBOLT AB

TEL 08 - 555 975 00 FAX 08 - 583 581 82

ARTIKELLISTA

2013-2014

DELGÄNGAD SEXKANTSKRUV

M6S 8.8 FZV ISO 4014

VARMFÖRZINKAD

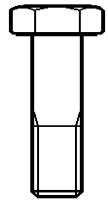

GÄNGA	M8	M10	M12	M16	M18	M20	M22	M24	M27	M30	M33	M36
Nyckelv	13	16	18	24	27	30	34	36	41	46	50	55
Skallh	5.3	6.4	7.5	10	11.5	12.5	14	15	17	18.7	21	22.5
Gängl	22	26	30	38	42	46	50	54	60	66	72	78
120 ->		32	36	44	48	52	56	60	66	72	78	84
200 ->				57	61	65		73	79	85	91	97
Längd	C:A PRIS / 100 ST											
35	X											
40	X	X										
45	X	X	X									
50	X	X	X									
55	X	X	X	X								
60	X	X	X	X								
65	X	X	X	X		X						
70	X	X	X	X	X	X						
75	X	X	X	X	X	X		X				
80	X	X	X	X	X	X		X	X			
90	X	X	X	X	X	X	X	X	X	X		
100	X	X	X	X	X	X	X	X	X	X	X	
110	X	X	X	X	X	X	X	X	X	X	X	X
120	X	X	X	X	X	X	X	X	X	X	X	X
130	X	X	X	X	X	X	X	X	X	X	X	X
140		X	X	X	X	X	X	X	X	X	X	X
150		X	X	X	X	X	X	X	X	X	X	X
160		X	X	X		X	X	X	X	X	X	X
180		X	X	X		X	X	X	X	X	X	X
200		X	X	X		X		X	X	X	X	X
220		X	X	X		X		X	X	X	X	X
240		X	X	X		X		X	X	X	X	X
260		X	X	X		X		X	X	X	X	X
280			X	X		X		X	X	X	X	X
300			X	X		X		X	X	X	X	X
320				X		X		X	X	X		
340				X		X		X		X		
360				X		X		X		X		
380				X		X		X		X		
400				X		X		X		X		
450				X								
500				X								
550												
600												

KRYSSMARKERADE ARTIKLAR MOT FÖRFRÅGAN !
ÖVRIGA DIMENSIONER OCH LÅNGDER MOT FÖRFRÅGAN !

FÖRP.	M8	M10	M12	M16	M18	M20	M22	M24	M27	M30	M33	M36
100 ST	35-	45-										
50 ST		60-	50-									
25 ST		120-	100-	60-	70-							
10 ST			220-	110-	110-	65-	90-	75-	80-	90-	100-	
5 ST										140-	150-	110-
1 ST				260-		280-		260-		320-		220-

BESTÄLLNINGSEXEMPEL: 1111220120 - M6S M20x120 8.8 FZV

SWEBOLT AB

TEL 08 - 555 975 00 FAX 08 - 583 581 82

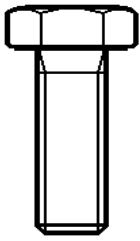

ARTIKELLISTA

2013-2014

HELGÄNGAD SEXKANTSKRUV

M6SH 10.9 ISO 4017 / DIN 933

OBEHANDLAD

					ISO	DIN	ISO	DIN	ISO	DIN	
GÄNGA	M4	M5	M6	M8	M10	M10	M12	M12	M14	M14	M16
Nyckelv	7	8	10	13	16	17	18	19	21	22	24
Skallh	2.8	3.5	4	5.3	6.4	6.4	7.5	7.5	8.8	8.8	10
Längd	C:A PRIS / 100 ST										
8											
10			X								
12			X	X							
14			X								
16			X	X	X	X		X			
20			X	X	X	X	X	X			
25			X	X	X	X	X	X	X	X	X
30			X	X	X	X	X	X	X	X	X
35			X	X	X	X	X	X	X	X	X
40			X	X	X	X	X	X	X	X	X
45			X	X	X	X	X	X	X	X	X
50			X	X	X	X	X	X	X	X	X
55			X	X	X	X	X	X	X	X	X
60			X	X	X	X	X	X	X	X	X
65				X	X	X	X	X		X	X
70			X	X	X	X	X	X	X	X	X
75				X	X	X	X	X		X	X
80			X	X	X	X	X	X	X	X	X
90				X		X		X		X	X
100			X	X		X		X		X	X
110				X		X		X		X	X
120				X		X		X		X	X
130				X		X		X		X	X
140				X		X		X		X	X
150				X		X		X		X	X
160				X		X		X		X	X
180				X		X		X		X	X
200				X		X		X		X	X
220											X
240											X
260											X
280											X
300											X

KRYSSMARKERADE ARTIKLAR MOT FÖRFRÅGAN !
ÖVRIGA DIMENSIONER OCH LÄNGDER MOT FÖRFRÅGAN !

FÖRP.	M4	M5	M6	M8	M10	M10	M12	M12	M14	M14	M16
500 ST			12-								
200 ST				12-	16-	20-					
100 ST				45-	35-	35-	20-	20-	25-	25-	
50 ST				100-		100-	70-	70-	45-	45-	25-
25 ST									140-	140-	65-
10 ST											130-

BESTÄLLNINGSEXEMPEL: 1113208020 - M6SH M8X20 10.9

BESTÄLLNINGSEXEMPEL: 1112612050 - M6SH M12X50 10.9 DIN 933

SWEBOLT AB

TEL 08 - 555 975 00 FAX 08 - 583 581 82

ARTIKELLISTA
2013-2014
HELGÄNGAD SEXKANTSKRUV
M6SH 10.9 ISO 4017 / DIN 933
OBEHANDLAD

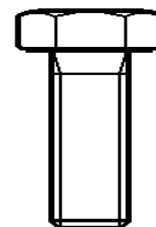

DIN							
GÄNGA	M18	M20	M22	M24	M27	M30	M36
Nyckelv	27	30	32	36	41	46	55
Skallh	11.5	12.5	14	15	17	18.7	22.5
Längd	C:A PRIS / 100 ST						
30	X	X					
35	X	X					
40	X	X					
45	X	X					
50	X	X	X	X	X	X	X
55	X	X	X	X	X	X	X
60	X	X	X	X	X	X	X
65	X	X	X	X	X	X	X
70	X	X	X	X	X	X	X
75	X	X	X	X	X	X	X
80	X	X	X	X	X	X	X
90	X	X	X	X	X	X	X
100	X	X	X	X	X	X	X
110	X	X	X	X	X	X	X
120	X	X	X	X	X	X	X
130	X	X	X	X	X	X	X
140	X	X	X	X	X	X	X
150	X	X	X	X	X	X	X
160	X	X	X	X	X	X	X
180	X	X	X	X	X	X	X
200	X	X	X	X	X	X	X
220		X		X		X	X
240		X		X		X	X
260		X		X		X	X
280		X		X		X	X
300		X		X		X	X

KRYSSMARKERADE ARTIKLAR MOT FÖRFRÅGAN !
 ÖVRIGA DIMENSIONER OCH LÅNGDER MOT FÖRFRÅGAN !

FÖRP.	M18	M20	M22	M24	M27	M30	M36
50 ST	30-	30-					
25 ST	55-	45-	50-	50-	50-		
10 ST		160-	100-	110-	100-	50-	50-
5 ST							70-

BESTÄLLNINGSEXEMPEL: 1113220050 - M6SH M20X50 10.9

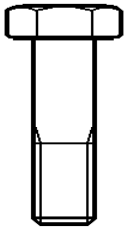

ARTIKELLISTA
2013-2014
DELGÄNGAD SEXKANTSKRUV
M6S 10.9 ISO 4014 / DIN 931
OBEHANDLAD

					ISO	DIN	ISO	DIN	ISO	DIN
GÄNGA	M4	M5	M6	M8	M10	M10	M12	M12	M14	M14
Nyckelv	7	8	10	13	16	17	18	19	21	22
Skallh	2.8	3.5	4	5.3	6.4	6.4	7.5	7.5	8.8	8.8
Gängl	14	16	18	22	26	26	30	30	34	34
120 ->					32	32	36	36	40	40
200 ->					45	45	49	49	53	53
Längd	C:A PRIS/100 ST									
30			X							
35			X	X						
40			X	X	X	X				
45			X	X	X	X	X	X		
50			X	X	X	X	X	X	X	X
55			X	X	X	X	X	X	X	X
60			X	X	X	X	X	X	X	X
65			X	X	X	X	X	X	X	X
70			X	X	X	X	X	X	X	X
75			X	X	X	X	X	X	X	X
80			X	X	X	X	X	X	X	X
90			X	X	X	X	X	X	X	X
100			X	X	X	X	X	X	X	X
110			X	X	X	X	X	X	X	X
120			X	X	X	X	X	X	X	X
130				X	X	X	X	X	X	X
140				X	X	X	X	X	X	X
150				X	X	X	X	X		X
160				X		X	X	X		X
180				X		X	X	X		X
200				X		X	X	X		X
220				X		X		X		X
240				X		X		X		X
260				X		X		X		X
280				X		X		X		X
300				X		X		X		X
320						X		X		X
340						X		X		X
360						X		X		X
380						X		X		X
400						X		X		X

KRYSSMARKERADE ARTIKLAR MOT FÖRFRÅGAN !
 ÖVRIGA DIMENSIONER OCH LÄNGDER MOT FÖRFRÅGAN !

FÖRP.	M4	M5	M6	M8	M10	M10	M12	M12	M14	M14
200 ST			30-	35-						
100 ST			100-	75-	40-	40-	45-	45-	50-	50-
50 ST				130-	90-	90-	70-	70-	70-	70-
25 ST							160-	160-	140-	140-

BESTÄLLNINGSEXEMPEL: 1113008100 - M6S M8x100 10.9

SWEBOLT AB
TEL 08 - 555 975 00 FAX 08 - 583 581 82

ARTIKELLISTA
2013-2014
DELGÄNGAD SEKKANTSKRUV
M6S 10.9 ISO 4014 / DIN 931
OBEHANDLAD

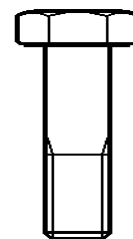

	DIN								
GÄNGA	M16	M18	M20	M22	M24	M27	M30	M36	M48
Nyckelv	24	27	30	32	36	41	46	55	75
Skallh	10	11.5	12.5	14	15	17	18.7	22.5	30
Gängl	38	42	46	50	54	60	66	78	102
120 ->	44	48	52	56	60	66	72	84	108
200 ->	57	61	65	63	73	79	85	97	121
Längd	C:A PRIS / 100 ST								
55	X								
60	X	X							
65	X	X	X						
70	X	X	X	X					
75	X	X	X	X	X				
80	X	X	X	X	X				
90	X	X	X	X	X				
100	X	X	X	X	X	X	X	X	
110	X	X	X	X	X	X	X	X	
120	X	X	X	X	X	X	X	X	X
130	X	X	X	X	X	X	X	X	X
140	X	X	X	X	X	X	X	X	X
150	X	X	X	X	X	X	X	X	X
160	X	X	X	X	X	X	X	X	X
180	X	X	X	X	X	X	X	X	X
200	X	X	X	X	X	X	X	X	X
220	X	X	X	X	X	X	X	X	X
240	X	X	X	X	X	X	X	X	X
250	X	X	X	X	X	X	X	X	X
260	X	X	X	X	X	X	X	X	X
280	X	X	X	X	X	X	X	X	X
300	X	X	X	X	X	X	X	X	X
320	X	X	X	X	X	X	X	X	X
340	X	X	X	X	X	X	X	X	X
360	X	X	X	X	X	X	X	X	X
380	X	X	X	X	X	X	X	X	X
400	X	X	X	X	X	X	X	X	X
420			X	X	X	X	X	X	X
440			X	X	X	X	X	X	X
460			X	X	X	X	X	X	X
480			X	X	X	X	X	X	X
500			X	X	X	X	X	X	X

KRYSSMARKERADE ARTIKLAR MOT FÖRFRÅGAN !
 ÖVRIGA DIMENSIONER OCH LÄNGDER MOT FÖRFRÅGAN !

FÖRP.	M16	M18	M20	M22	M24	M27	M30	M36	M48
50 ST	55-								
25 ST	65-	60-	65-		75-				
10 ST	220-	160-	160-	70-	90-	80-	100-		
5 ST				100-	260-				
1 ST			250-			260-	260-	100-	120-

BESTÄLLNINGSEXEMPEL: 1113020160 - M6S M20X160 10.9

SWEBOLT AB
TEL 08 - 584 909 60 FAX 08 - 583 581 82

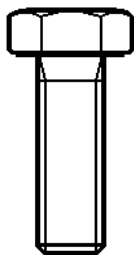

ARTIKELLISTA

2013-2014

HELGÄNGAD SEXKANTSKRUV M6SH 12.9 ISO 4017 / DIN 933 OBEHANDLAD

		ISO	DIN	ISO	DIN	ISO	DIN				DIN			
GÄNGA	M6	M8	M10	M10	M12	M12	M14	M14	M16	M18	M20	M22	M24	M27
Nyckelv	10	13	16	17	18	19	21	22	24	27	30	32	36	41
Skallh	4	5.3	6.4	7.5	7.5	7.5	8.8	8.8	10	11.5	12.5	14	15	17
Längd	C:A PRIS/100ST													
10														
12	X													
16	X	X												
20		X		X										
25	X	X		X		X								
30	X	X		X		X			X					
35		X		X		X		X	X					
40	X	X		X		X		X	X		X			
45				X		X		X	X		X			
50		X		X		X		X	X		X		X	
55		X							X		X		X	
60		X		X		X			X		X		X	
65									X		X		X	
70									X		X		X	
80									X		X		X	
90											X		X	
100									X		X		X	

ÖVRIGA DIMENSIONER OCH LÄNGDER MOT FÖRFRÅGAN !

FÖRP.	M6	M8	M10	M10	M12	M12	M14	M14	M16	M18	M20	M22	M24	M27
200 ST	12-	16-	20-											
100 ST	40-	40-	35-			30-	35-							
50 ST						50-	45-	30-						
25 ST								70-		40-			50-	
10 ST													90-	

BESTÄLLNINGSEXEMPEL: 1112908020 = M6SH M8x20 12.9

BESTÄLLNINGSEXEMPEL: 1112812030 = M6SH M12x30 12.9

SWEBOLT AB

TEL 08 - 555 975 00 FAX 08 - 583 581 82

ARTIKELLISTA

2013-2014

DELGÄNGAD SEXKANTSKRUV M6S 12.9 ISO 4014 / DIN 931 OBEHANDLAD

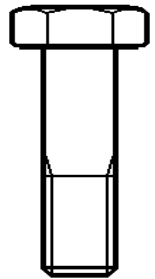

			ISO	DIN	ISO	DIN	ISO	DIN				DIN		
GÄNGA	M6	M8	M10	M10	M12	M12	M14	M14	M16	M18	M20	M22	M24	M30
Nyckelv	10	13	16	17	18	19	21	22	24	27	30	32	36	46
Skallh	4	5.3	6.4	7.5	7.5	7.5	8.8	8.8	10	11.5	12.5	14	15	18.7
Gängl	18	22	26	30	30	30	34	34	38	42	46	50	54	66
120->			32	36	36	36	40	40	44	48	52	56	60	72
200->							53	53	57	61	65	69	73	85
Längd	C:A PRIS/100ST													
30														
35														
40		X		X										
45		X		X		X								
50		X		X		X		X						
55						X			X					
60				X		X		X	X					
65						X			X					
70				X		X			X		X			
75														
80				X		X		X	X		X		X	
90				X		X			X		X		X	X
100				X		X		X	X		X		X	X
110											X		X	X
120				X		X			X		X		X	X
130									X		X		X	X
140						X			X		X		X	X
150									X		X		X	X
160													X	X
180											X		X	X
200													X	X
220													X	
240													X	

ÖVRIGA DIMENSIONER OCH LÄNGDER MOT FÖRFRÅGAN !

FÖRP.	M6	M8	M10	M10	M12	M12	M14	M14	M16	M18	M20	M22	M24	M27
200 ST		40-												
100 ST				50-		50-								
50 ST						70-			55-					
25 ST									65-		70-			
10 ST											110-		80-	
5 ST														90-

BESTÄLLNINGSEXEMPEL: 1111908050 = M6S M8x50 12.9

SWEBOLT AB

TEL 08 - 555 975 00 FAX 08 - 583 581 82

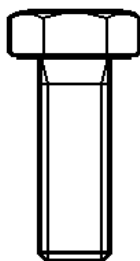

ARTIKELLISTA

2013-2014

FINGÄNGAD HELGÄNGAD SEXKANTSKRUV

FM6SH 8.8 ISO 8676 / DIN 961

OBEHANDLAD

		ISO	DIN	ISO	DIN	DIN	DIN						
GÄNGA	M8	M10	M10	M12	M12	M12	M14	M16	M18	M20	M20	M24	M24
Stign.	1.0	1.0	1.25	1.5	1.5	1.25	1.5	1.5	1.5	1.5	2.0	1.5	2.0
Nyckelv	13	16	17	18	19	19	22	24	27	30	30	36	36
Skallh	5.3	6.4	6.4	7.5	7.5	7.5	8.8	10	11.5	12.5	12.5	15	15
Längd	C:A/PRIS100 ST												
10	X												
12	X		X										
16	X		X		X								
20	X		X		X	X							
25	X		X		X	X	X						
30	X		X		X	X	X	X	X				
35	X		X		X	X	X	X	X				
40	X		X		X	X	X	X	X	X			X
45	X				X		X	X	X	X			X
50	X		X		X		X	X	X	X	X		X
55	X							X	X	X		X	X
60	X		X		X		X	X	X	X		X	X
65	X		X		X		X	X	X	X		X	X
70	X		X		X		X	X	X	X		X	X
75	X		X		X		X	X	X	X		X	X
80	X		X		X		X	X	X	X		X	X
90	X		X		X		X	X	X	X		X	X
100	X		X		X		X	X	X	X		X	X
110												X	X
120												X	X
130													

KRYSSMARKERADE ARTIKLAR MOT FÖRFRÅGAN !
ÖVRIGA DIMENSIONER OCH LÄNGDER MOT FÖRFRÅGAN !

FÖRP.	M8	M10	M10	M12	M12	M12	M14	M16	M18	M20	M20	M22	M24
200 ST	10-	12-	12-	16-	16-								
100 ST	60-	45-	45-	30-	30-	25-	20-						
50 ST			80-		60-		70-	20-	30-	30-			
25 ST								65-	60-	40-		40-	50-
10 ST												100-	100-

BESTÄLLNINGSEXEMPEL: 1115016150030 - FM6SH M16x1.5x30 8.8 ISO 8676

BESTÄLLNINGSEXEMPEL 1115214150040 - FM6SH M14x1.5x40 8.8 DIN 961

SWEBOLT AB

TEL 08 - 555 975 00 FAX 08 - 583 581 82

ARTIKELLISTA
2013-2014
FINGÄNGAD DELGÄNGAD SEXKANTSKRUV
FM6S 8.8 ISO 8765 / DIN 960
OBEHANDLAD

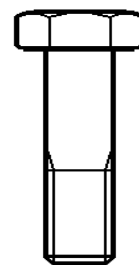

		ISO	DIN	ISO	DIN	DIN	DIN					DIN	
GÄNGA	M8	M10	M10	M12	M12	M12	M14	M16	M18	M20	M20	M22	M24
Stign.	1.0	1.0	1.25	1.5	1.5	1.25	1.5	1.5	1.5	1.5	2.0	2.0	2.0
Nyckelv	13	16	17	18	19	19	22	24	27	30	30	32	36
Skallh	5.3	6.4	6.4	7.5	7.5	7.5	8.8	10	11.5	12.5	12.5	14	15
Gängl	22	26	26	30	30	30	34	38	42	46	46	50	54
120 ->		32	32	36	36	36	40	44	48	52	52	56	60
Längd	C:A PRIS / 100 ST												
35	X												
40	X		X										
45	X		X										
50	X		X		X		X						
55	X		X		X		X						
60	X		X		X	X	X	X	X				
65	X		X		X		X	X				X	
70	X		X		X	X	X	X	X	X		X	X
75	X		X						X			X	X
80	X		X		X	X	X	X	X	X		X	X
90	X		X		X		X	X	X	X		X	X
100	X		X		X		X	X	X	X		X	X
110	X		X		X		X		X	X		X	X
120	X		X		X		X	X	X	X		X	X
130			X		X		X	X	X	X		X	X
140			X		X		X	X	X	X		X	X
150			X		X		X	X	X	X		X	X
160			X		X		X	X	X	X		X	X
180			X		X		X	X	X	X		X	X
200								X	X	X		X	X
220								X	X	X		X	X

KRYSSMARKERADE ARTIKLAR MOT FÖRFRÅGAN !
 ÖVRIGA DIMENSIONER OCH LÄNGDER MOT FÖRFRÅGAN !

FÖRP.	M8	M10	M10	M12	M12	M12	M14	M16	M18	M20	M20	M22	M24
100 ST	35-	40-	40-										
50 ST		60-	60-	45-	45-		50-						
25 ST		110-	110-	100-	100-		75-	50-	55-	60-		65-	70-
10 ST								160-	110-	110-		100-	100-

BESTÄLLNINGSEXEMPEL: 1114020150090 - FM6S M20x1.5x90 8.8 OBEH ISO 8765
 BESTÄLLNINGSEXEMPEL: 1114212150050 - FM6S M12x1.5x50 8.8 OBEH DIN 960

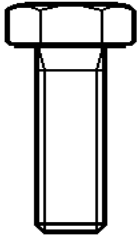

ARTIKELLISTA

2013-2014

FINGÄNGAD HELGÄNGAD SEXKANTSKRUV FM6SH 8.8 ISO 8676 / DIN 961 FZB BLANKFÖRZINKAD

GÄNGA	M8	DIN M10	DIN M10	ISO M12	DIN M12	DIN M12	DIN M12	DIN M14	M16	M18	M20	M20	DIN M22	M24
Stign.	1.0	1.0	1.25	1.5	1.5	1.25	1.5	1.5	1.5	1.5	1.5	2.0	1.5	2.0
Nyckelv	13	17	17	18	19	19	19	22	24	27	30	30	32	36
Skallh	5.3	6.4	6.4	7.5	7.5	7.5	7.5	8.8	10	11.5	12.5	12.5	14	15
Längd	C:A/PRIS100 ST													
10														
12														
16	X													
20	X	X	X		X									
25	X	X	X	X	X	X	X	X	X					
30	X	X	X	X	X	X	X	X	X	X	X			
35	X	X	X	X	X	X	X	X	X	X	X			
40	X	X	X	X	X	X	X	X	X	X	X		X	X
45	X	X	X	X	X	X	X	X	X	X	X		X	X
50	X	X	X	X	X	X	X	X	X	X	X		X	X
55	X		X	X	X			X	X	X	X		X	X
60	X		X	X	X			X	X	X	X		X	X
65	X		X	X	X			X	X	X	X		X	X
70	X		X	X	X			X	X	X	X		X	X
75	X		X		X			X	X	X	X		X	X
80	X		X		X			X	X	X	X		X	X
90	X		X		X			X	X	X	X		X	X
100	X		X		X			X	X	X	X			X
110														X
120														X
130														X

KRYSSMARKERADE ARTIKLAR MOT FÖRFRÅGAN!
ÖVRIGA DIMENSIONER OCH LÄNGDER MOT FÖRFRÅGAN!

FÖRP.	M8	M10	M10	M12	M12	M12	M14	M16	M18	M20	M20	M22	M24
200 ST	10-	20-	12-	25-	16-								
100 ST	60-	45-	45-	30-	30-	25-	20-						
50 ST			80-	60-	60-		70-	20-	30-	30-			
25 ST								65-	60-	40-		40-	40-
10 ST													80-

BESTÄLLNINGSEXEMPEL: 1115120150050 - FM6SH M20X1.5X20 8.8 FZB
BESTÄLLNINGSEXEMPEL: 1115310125020 - FM6SH M12X1.25X20 8.8 FZB DIN

SWEBOLT AB

TEL 08 - 555 975 00 FAX 08 - 583 581 82

ARTIKELLISTA

2013-2014

FINGÄNGAD DELGÄNGAD SEXKANTSKRUV

FM6S 8.8 ISO 8765 / DIN 960 FZB

BLANKFÖRZINKAD

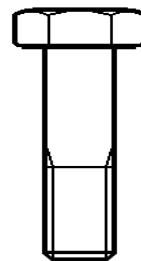

		ISO	DIN	ISO	DIN	DIN	DIN					DIN	
GÄNGA	M8	M10	M10	M12	M12	M12	M14	M16	M18	M20	M20	M22	M24
Stign.	1.0	1.0	1.25	1.5	1.5	1.25	1.5	1.5	1.5	1.5	2.0	2.0	2.0
Nyckelv	13	16	17	18	19	19	22	24	27	30	30	32	36
Skallh	5.3	6.2	6.4	7.5	7.5	7.5	8.8	10	11.5	12.5	12.5	14	15
Gängl	22	26	26	30	30	30	34	38	42	46	46	50	54
120 ->		32	32	36	36	36	40	44	48	52	52	56	60
Längd	C:A/PRIS100 ST												
35	X												
40	X	X	X										
45	X	X	X	X									
50	X	X	X	X	X	X	X						
55	X	X	X	X	X		X	X	X				
60	X	X	X	X	X		X	X	X				
65	X	X	X	X	X		X	X	X			X	
70	X	X	X	X	X		X	X	X	X	X	X	X
75	X	X	X	X	X		X	X	X	X	X	X	X
80	X	X	X	X	X		X	X	X	X	X	X	X
90	X	X	X	X	X		X	X	X	X	X	X	X
100	X	X	X	X	X		X	X	X	X	X	X	X
110	X		X		X		X	X	X	X	X	X	X
120	X		X		X		X	X	X	X	X	X	X
130			X		X		X	X	X	X	X	X	X
140			X		X		X	X	X	X	X	X	X
150			X		X		X	X	X	X	X	X	X
160			X		X		X	X	X	X	X	X	X
180			X		X		X	X	X	X	X	X	X
200								X	X	X	X	X	X
220								X	X	X	X	X	X

KRYSSMARKERADE ARTIKLAR MOT FÖRFRÅGAN!
ÖVRIGA DIMENSIONER OCH LÄNGDER MOT FÖRFRÅGAN!

FÖRP.	M8	M10	M10	M12	M12	M12	M14	M16	M18	M20	M20	M22	M24
100 ST	35-	40-	40-										
50 ST		60-	60-	45-	45-		50-						
25 ST		110-	110-	100-	100-		75-	50-	55-	60-	75-	65-	
10 ST								160-	110-	110-		100-	70-

BESTÄLLNINGSEXEMPEL: 1114120150100 - FM6S M20X1.5X100 8.8 FZB

BESTÄLLNINGSEXEMPEL: 1114312150070 - FM6S M12X1.5X70 8.8 FZB DIN

SWEBOLT AB

TEL 08 - 584 909 60 FAX 08 - 583 581 82

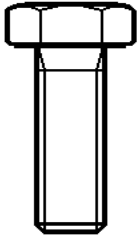

ARTIKELLISTA

2013-2014

FINGÄNGAD HELGÄNGAD SEXKANTSKRUV FM6SH 10.9 ISO 8676 / DIN 961 OBEHANDLAD

		ISO	DIN	DIN	DIN	ISO	DIN					DIN	
GÄNGA	M8	M10	M10	M10	M12	M12	M14	M16	M18	M20	M20	M22	M24
Stign.	1.0	1.0	1.25	1.0	1.5	1.25	1.5	1.5	1.5	1.5	2.0	1.5	2.0
Nyckelv	13	16	17	17	19	19	22	24	27	30	30	32	36
Skallh	5.3	6.4	6.4	6.4	7.5	7.5	8.8	10	11.5	12.5	12.5	14	15
Längd	C:A/PRIS100 ST												
10													
12													
16													
20	X			X	X	X							
25	X		X	X	X	X	X						
30	X		X	X	X	X	X	X	X	X			
35	X		X	X	X	X	X	X	X	X			
40	X		X	X	X	X	X	X	X	X	X	X	
45			X	X	X	X	X	X	X	X			
50			X	X	X	X	X	X	X	X			
55							X	X	X	X			
60					X	X	X	X	X	X			
65								X		X			
70						X	X	X	X	X			
75													
80							X	X	X	X			X
90								X	X	X			
100								X	X	X			
110													
120								X	X				
130													

KRYSSMARKERADE ARTIKLAR MOT FÖRFRÅGAN!
ÖVRIGA DIMENSIONER OCH LÄNGDER MOT FÖRFRÅGAN!

FÖRP.	M8	M10	M10	M10	M12	M12	M14	M16	M18	M20	M20	M22	M24
200 ST	10-	20-	12-	25-	16-								
100 ST	60-	45-	45-	30-	30-	25-	20-						
50 ST			80-	60-	60-		70-	20-	30-	30-			
25 ST								65-	60-	40-		40-	40-
10 ST													80-

BESTÄLLNINGSEXEMPEL: 1114420150040 - FM6SH M20x1.5x40 10.9

BESTÄLLNINGSEXEMPEL: 1114612150035 - FM6SH M12x1.25x35 10.9 DIN

SWEBOLT AB

TEL 08 - 555 975 00 FAX 08 - 583 581 82

ARTIKELLISTA

2013-2014

FINGÄNGAD DELGÄNGAD SEXKANTSKRUV

FM6S 10.9 ISO 8765 / DIN 960

OBEHANDLAD

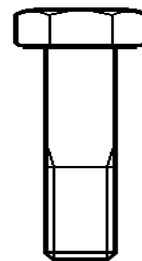

	ISO	DIN	ISO	DIN	DIN	DIN					DIN		
GÄNGA	M8	M10	M10	M12	M12	M12	M14	M16	M18	M20	M20	M22	M24
Stign.	1.0	1.0	1.25	1.5	1.5	1.25	1.5	1.5	1.5	1.5	2.0	1.5	2.0
Nyckelv	13	16	17	18	19	19	22	24	27	30	30	32	36
Skallh	5.3	6.2	6.4	7.5	7.5	7.5	8.8	10	11.5	12.5	12.5	14	15
Gängl	22	26	26	30	30	30	34	38	42	46	46	50	54
120 ->		32	32	36	36	36	40	44	48	52	52	56	60
Längd	C:A/PRIS100 ST												
35													
40													
45			X		X	X							
50			X		X	X	X						
55					X		X	X					
60			X		X		X	X	X				
65					X		X	X	X	X			
70			X		X		X	X	X	X	X	X	
75					X		X	X		X			
80					X		X	X	X	X	X		
90					X		X	X	X	X	X		X
100					X		X	X	X	X	X		X
110							X	X		X	X		
120					X		X	X	X	X	X		X
130										X	X		
140							X	X	X	X	X	X	
150								X		X			
160							X	X	X	X			
180										X			
200										X			
220													

KRYSSMARKERADE ARTIKLAR MOT FÖRFRÅGAN!
ÖVRIGA DIMENSIONER OCH LÄNGDER MOT FÖRFRÅGAN!

FÖRP.	M8	M10	M10	M12	M12	M12	M14	M16	M18	M20	M20	M22	M24
100 ST	35-	40-	40-										
50 ST		60-	60-	45-	45-		50-						
25 ST		110-	110-	100-	100-		75-	50-	55-	60-	75-	65-	
10 ST								160-	110-	110-		100-	70-

BESTÄLLNINGSEXEMPEL: 1113416150100 - FM6S M16x1.5x100 10.9

BESTÄLLNINGSEXEMPEL: 1113612125045 - FM6S M12x1.25x45 10.9 DIN

SWEBOLT AB

TEL 08 - 555 975 00 FAX 08 - 583 581 82

ARTIKELLISTA
2013-2014
SEKKANTSKRUV MED FLÄNS
M6SF 8.8 FZB DIN 6921
BLANKFÖRZINKAD



GÄNGA	M6	M8	M10	M12	M14	M16
Nyckelv	10	13	15 (16)	16 (18)	18	21
Skallh	6.6	8.1	9.2	11.5	12.8	14.4
Flänsdiam	14.2	18	22.3	26.6	30.5	35
Gänglängd	18	22	26	30	34	44
Längd	C:A PRIS / 100 ST					
8						
10	X					
12	X	X				
16	X	X	X			
20	X	X	X	X		
25	X	X	X	X		
30	X	X	X	X		
35	X	X	X	X		
40	X	X	X	X		
45						
50	X	X	X	X	X	
55						
60	X	X		X		
65						
70			X	X		
75						
80		X	X	X		
90			X	X		
100				X		
110		X		X		
120			X			
130			X			
140						
150			X			

ÖVRIGA DIMENSIONER OCH LÄNGDER MOT FÖRFRÅGAN !

FÖRP.	M6	M8	M10	M12	M14	M16
200 ST	10-					
100 ST		16-	20-	25-		
50 ST			70-	50-		
25 ST						

BESTÄLLNINGSEXEMPEL: 1117112025 - M6SF M12X25 8.8 FZB

SWEBOLT AB
TEL 08 - 555 975 00 FAX 08 - 583 581 82

ARTIKELLISTA
2013-2014
M6SFT TENSILOCK
DIN 6921 TANDAD FLÄNSSKRUV

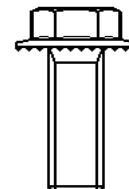

GÄNGA	M3	M4	M5	M6	M8	M10	M12
Nyckelv			8	10	13	15 (16)	16 (18)
Skallh			5.4	6.6	8.1	9.2	11.5
Flänsdiam			11.2	14.2	18	22.3	26.6
Gänglängd				18	22	26	30
Längd	C:A PRIS / 100 ST						
10				X			
12				X			
16				X	X		
20				X	X	X	
25				X	X	X	
30				X	X	X	
35							
40						X	
45							
50							
60							
70							
80							
100							
FÖRP.	M3	M4	M5	M6	M8	M10	M12
200 ST				10-			
100 ST					16-	20-	

BESTÄLLNINGSEXEMPEL: 1118110025 - M6SFT M10X25 FZB

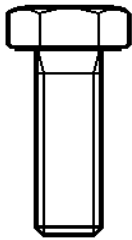

ARTIKELLISTA

2013-2014

HELGÄNGAD SEXKANTSKRUV M6SH 5.8 FZB DIN 558 / ISO 4018 BLANKFÖRZINKAD

GÄNGA	M5	M6	M8	M10	M12	M16	M20	M24
Nyckelv	8	10	13	17	19	24	30	36
Skallh	3.5	4	5.3	6.4	7.5	10	12.5	15
Längd	C:A PRIS/100 ST							
6								
8								
10	X	X	X					
12	X	X	X					
14								
16	X	X	X	X				
18								
20	X	X	X	X	X			
22								
25	X	X	X	X	X			
30	X	X	X	X	X	X	X	
35	X	X	X	X	X	X	X	
40	X	X	X	X	X	X	X	X
45	X	X	X	X	X	X	X	X
50	X	X	X	X	X	X	X	X
55		X	X	X	X		X	X
60		X	X	X	X	X	X	X
65			X	X	X		X	X
70		X	X	X	X	X	X	X
75								
80		X	X	X	X	X	X	
90		X	X	X	X	X	X	
100		X	X	X	X	X	X	
110			X	X	X			
120				X	X			
130								
140								
150								
160								
180								
200								
220								
240								
260								
280								
300								

KRYSSMARKERADE ARTIKLAR MOT FÖRFRÅGAN !

ÖVRIGA DIMENSIONER OCH LÄNGDER MOT FÖRFRÅGAN OCH LEVERANSTID

FÖRP.	M5	M6	M8	M10	M12	M16	M20	M24
500 ST	10-	10-						
200 ST	35-	35-	10-	16-				
100 ST		90-	90-	35-	20-			
50 ST				110-	65-	30-		
25 ST						70-	30-	40-
10 ST								

BESTÄLLNINGSEXEMPEL: 1110210020 - M6SH M10x20 5.8 FZB DIN 558

SWEBOLT AB

TEL 08 - 555 975 00 FAX 08 - 583 581 82

ARTIKELLISTA

2013-2014

DELGÄNGAD SEXKANTSKRUV M6S 4.6 OBEH DIN 601 / ISO 4016 OBEHANDLAD

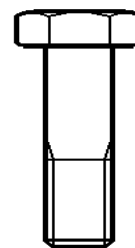

GÄNGA	M5	M6	M8	M10	M12	M16	M20	M24	M30	M36
Nyckelv	8	10	13	17	19	24	30	36	46	55
Skallh	3.5	4	5.3	6.4	7.5	10	12.5	15	18.7	22.5
Gängl	16	18	22	26	30	38	46	54	66	
125 ->	22	24	28	32	36	44	52	60	72	84
200 ->	35	37	41	45	49	57	65	73	85	97
Längd	C:A PRIS / 100ST									
30	X	X								
35	X	X	X							
40	X	X	X	X						
45	X	X	X	X	X					
50	X	X	X	X	X					
55	X	X	X	X	X	X				
60	X	X	X	X	X	X				
65	X	X	X	X	X	X	X			
70	X	X	X	X	X	X	X	X		
75		X	X	X	X	X	X	X		
80		X	X	X	X	X	X	X	X	
90		X	X	X	X	X	X	X	X	X
100		X	X	X	X	X	X	X	X	X
110		X	X	X	X	X	X	X	X	X
120		X	X	X	X	X	X	X	X	X
130		X	X	X	X	X	X	X	X	X
140		X	X	X	X	X	X	X	X	X
150			X	X	X	X	X	X	X	X
160			X	X	X	X	X	X	X	X
180			X	X	X	X	X	X	X	X
200			X	X	X	X	X	X	X	X
220				X	X	X	X	X	X	X
240				X	X	X	X	X	X	X
260				X	X	X	X	X	X	X
280				X	X	X	X	X	X	X
300				X	X	X	X	X	X	X
320					X	X	X	X	X	X
340					X	X	X	X	X	X
360					X	X	X	X	X	X
380					X	X	X	X	X	X
400					X	X	X	X	X	X
420					X	X	X	X	X	X
440					X	X	X	X	X	X
460					X	X	X	X	X	X
480					X	X	X	X	X	X
500					X	X	X	X	X	X
520						X	X	X	X	X
540						X	X	X	X	X
560						X	X	X	X	X
580						X	X	X	X	X
600						X	X	X	X	X
620						X	X	X	X	X
640						X	X	X	X	X
660						X	X	X	X	X
680						X	X	X	X	X
700						X	X	X	X	X

KRYSSMARKERADE ARTIKLAR MOT FÖRFRÅGAN !

ÖVRIGA DIMENSIONER OCH LÅNGDER MOT LEVERANSTID OCH FÖRFRÅGAN!
BESTÄLLNINGSEXEMPEL DIN: 1110510240 - M6S M10x240 4.6 OBEH DIN 601

SWEBOLT AB

TEL 08 - 584 909 60 FAX 08 - 583 581 82

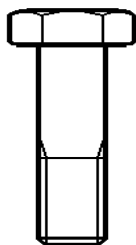

ARTIKELLISTA

2013-2014

DELGÄNGAD SEXKANTSKRUV

M6S 4.6 FZB DIN 601 / ISO 4016

BLANKFÖRZINKAD

GÄNGA	M5	M6	M8	M10	M12	M16	M20	M24	M30	M36
Nyckelv	8	10	13	17	19	24	30	36	46	55
Skallh	3.5	4	5.3	6.4	7.5	10	12.5	15	18.7	22.5
Gängl	16	18	22	26	30	38	46	54	66	
125 ->	22	24	28	32	36	44	52	60	72	84
200 ->	35	37	41	45	49	57	65	73	85	97
Längd	C:A PRIS / 100 ST									
30	X	X								
35	X	X	X							
40	X	X	X	X						
45	X	X	X	X	X					
50	X	X	X	X	X					
55	X	X	X	X	X	X				
60	X	X	X	X	X	X				
65	X	X	X	X	X	X	X			
70	X	X	X	X	X	X	X	X		
75		X	X	X	X	X	X	X	X	
80		X	X	X	X	X	X	X	X	
90		X	X	X	X	X	X	X	X	
100		X	X	X	X	X	X	X	X	
110		X	X	X	X	X	X	X	X	
120		X	X	X	X	X	X	X	X	
130		X	X	X	X	X	X	X	X	
140		X	X	X	X	X	X	X	X	
150			X	X	X	X	X	X	X	
160			X	X	X	X	X	X		
180			X	X	X	X	X	X		
200			X	X	X	X	X	X		
220				X	X	X	X			
240				X	X	X	X			
260				X	X	X	X			
280				X	X	X	X			
300				X	X	X	X			
320					X	X	X			
340					X	X	X			
360					X	X	X			
380					X	X	X			
400					X	X	X			
420					X	X	X			
440					X	X	X			
460					X	X	X			
480					X	X	X			
500					X	X	X			
520						X	X			
540						X	X			
560						X	X			
580						X	X			
600						X	X			
620						X	X			
640						X	X			
660						X	X			
680						X	X			
700						X	X			

KRYSSMARKERADE ARTIKLAR MOT FÖRFRÅGAN !

ÖVRIGA DIMENSIONER OCH LÄNGDER MOT LEVERANSTID OCH FÖRFRÅGAN!

BESTÄLLNINGSEXEMPEL DIN: 1110410080 - M6S M10x240 4.6 FZB DIN 601

SWEBOLT AB

TEL 08 - 584 909 60 FAX 08 - 583 581 82

ARTIKELLISTA

2013-2014

DELGÄNGAD SEXKANTSKRUV

M6S 4.6 FZV DIN 601 / ISO 4016

VARMFÖRZINKAD

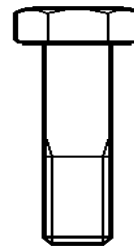

GÄNGA	M5	M6	M8	M10	M12	M16	M20	M24	M30	M36
Nyckelv	8	10	13	17	19	24	30	36	46	55
Skallh	3.5	4	5.3	6.4	7.5	10	12.5	15	18.7	22.5
Gängl	16	18	22	26	30	38	46	54	66	
125 ->	22	24	28	32	36	44	52	60	72	84
200 ->	35	37	41	45	49	57	65	73	85	97
Längd	C:A PRIS / 100 ST									
30	X	X								
35	X	X	X							
40	X	X	X	X						
45	X	X	X	X	X					
50	X	X	X	X	X					
55	X	X	X	X	X	X				
60	X	X	X	X	X	X				
65	X	X	X	X	X	X	X			
70	X	X	X	X	X	X	X	X		
75		X	X	X	X	X	X	X		
80		X	X	X	X	X	X	X	X	
90		X	X	X	X	X	X	X	X	X
100		X	X	X	X	X	X	X	X	X
110		X	X	X	X	X	X	X	X	X
120		X	X	X	X	X	X	X	X	X
130		X	X	X	X	X	X	X	X	X
140		X	X	X	X	X	X	X	X	X
150			X	X	X	X	X	X	X	X
160			X	X	X	X	X	X	X	X
180			X	X	X	X	X	X	X	X
200			X	X	X	X	X	X	X	X
220				X	X	X	X	X	X	X
240				X	X	X	X	X	X	X
260				X	X	X	X	X	X	X
280				X	X	X	X	X	X	X
300				X	X	X	X	X	X	X
320					X	X	X	X	X	X
340					X	X	X	X	X	X
360					X	X	X	X	X	X
380					X	X	X	X	X	X
400					X	X	X	X	X	X
420					X	X	X	X	X	X
440					X	X	X	X	X	X
460					X	X	X	X	X	X
480					X	X	X	X	X	X
500					X	X	X	X	X	X
520						X	X	X	X	X
540						X	X	X	X	X
560						X	X	X	X	X
580						X	X	X	X	X
600						X	X	X	X	X
620						X	X	X	X	X
640						X	X	X	X	X
660						X	X	X	X	X
680						X	X	X	X	X
700						X	X	X	X	X

KRYSSMARKERADE ARTIKLAR MOT FÖRFRÅGAN !

ÖVRIGA DIMENSIONER OCH LÄNGDER MOT LEVERANSTID OCH FÖRFRÅGAN!

BESTÄLLNINGSEXEMPEL DIN: 1110610240 - M6S M10x240 4.6 FZV DIN 601

SWEBOLT AB

TEL 08 - 584 909 60 FAX 08 - 583 581 82

ARTIKELLISTA
2013-2014
HV SKRUV FÖR HÖG FÖRSPÄNNING
HVS EN 14399-4 10.9 FZV

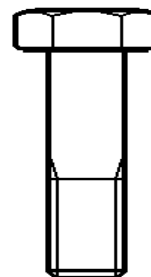

GÄNGA	M12	M16	M20	M24	M27	M30	M36
Nyckelv	22	27	32	41	46	50	60
Skallh	8	10	13	15	17	19	23
Gängl	21/23	26/28	31/33	34/37	37/39	40/42	48/50
Längd	C:A PRIS/100 ST						
30	X						
35	X	X					
40	X	X	X				
45	X	X	X				
50	X	X	X	X			
55	X	X	X	X			
60	X	X	X	X	X		
65	X	X	X	X	X		
70	X	X	X	X	X	X	
75		X	X	X	X	X	
80		X	X	X	X	X	
85		X	X	X	X	X	
90		X	X	X	X	X	
95		X	X	X	X	X	
100		X	X	X	X	X	X
105		X	X	X	X	X	
110		X	X	X	X	X	X
115		X	X	X	X	X	
120		X	X	X	X	X	X
125		X	X	X	X	X	
130		X	X	X	X	X	X
135				X	X	X	
140		X		X	X	X	X
145				X	X	X	
150		X		X	X	X	X
155				X	X	X	
160		X	X	X	X	X	X
180				X	X	X	X
200				X	X	X	X
GÄNGA	M12	M16	M20	M24	M27	M30	M36
HVM6MH		X	X	X	X	X	X
HVM6M	X	X	X	X	X	X	X
HVBRB	X	X	X	X	X	X	X

CERTIFIKAT 3.1B INGÅR

BESTÄLLNINGSEXEMPEL: 1129720080 - HVS M20x80 10,9 FZV
 BESTÄLLNINGSEXEMPEL: 13049200 - HVM6MH M20 -10 FZV 1xD
 BESTÄLLNINGSEXEMPEL: 14074240 - HVBRB M24 C45 FZV

SWEBOLT AB

TEL 08 - 555 975 00 FAX 08 - 583 581 82

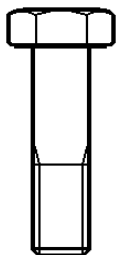

ARTIKELLISTA
2013-2014
SE XKANTSKRUV
U6S 8.8 UNC
OBEHANDLAD

GÄNGA	1/2"	9/16"	5/8"	3/4"	7/8"	1"	1 1/4"	1 1/2"
Stigning	3/4"	13/16"	15/16"	1 1/8"	1 5/16"	1 1/2"	1 7/8"	2 1/4"
Nyckelv	19	20.6	23.8	28.6	33.3	38.1	47.6	57.2
Nyckelv	7.9	9.1	9.9	11.9	13.9	15.5	19.8	23.8
Skallh	32	35	38	44	51	57	70	83
Gängl	38	35	44	51	57	64	76	89
Längd (tum mm)	C:A PRIS / 100 ST							
1/2 13								
5/8 16	X							
3/4 19	X							
7/8 22								
1" 25	X	X	X					
1 1/4 32	X	X	X	X				
1 1/2 38	X	X	X	X				
1 3/4 45	X	X	X	X	X			
2" 51	X	X	X	X	X	X		
2 1/4 57	X	X	X	X	X	X	X	
2 1/2 64	X	X	X	X	X	X	X	X
2 3/4 70	X	X	X	X	X	X	X	X
3" 76	X	X	X	X	X	X	X	X
3 1/4 83	X	X	X	X	X	X	X	X
3 1/2 89	X	X	X	X	X	X	X	X
3 3/4 95	X	X	X	X	X	X	X	X
4" 102	X	X	X	X	X	X	X	X
4 1/2 114	X	X	X	X	X	X	X	X
5" 127	X	X	X	X	X	X	X	X
5 1/2 140	X	X	X	X	X	X	X	X
6" 152	X	X	X	X	X	X	X	X
6 1/2 165			X	X	X	X	X	X
7" 178				X	X	X	X	X
7 1/2 191								
8" 203				X		X	X	X
9" 229						X	X	X
10" 254						X	X	X
11" 279							X	X
12" 305							X	X

ÖVRIGA DIMENSIONER OCH LÄNGDER MOT FÖRFRÅGAN !

FÖRP.	1/2"	9/16"	5/8"	3/4"	7/8"	1"	1 1/4"	1 1/2"
50 ST	19-	19-						
25 ST			25-	25-	38-	45-		
10 ST					114-	114-	64-	102-
5 ST					165-	165-	165-	165-

SWEBOLT AB

TEL 08 - 555 975 00 FAX 08 - 583 581 82

ARTIKELLISTA

2013-2014

SEXKANTSKRUV

U6S 8.8 FZB UNC ANSI B18.2.1

BLANKFÖRZINKAD

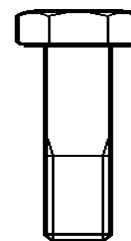

GÄNGA	1/4"	5/16"	3/8"	7/16"	1/2"	9/16"	5/8"	3/4"
Stigning	20	18	16	14	13	12	11	10
Nyckelv	7/16"	1/2"	9/16"	5/8"	3/4"	13/16"	15/16"	1 1/8"
Nyckelv	11.1	12.7	14.3	15.9	19	20.6	23.8	28.6
Skallh	4	5.2	6	7.1	7.9	9.1	9.9	11.9
Gängl	19	22	25	28	32	35	38	44
Längd (tum mm)	C:A PRIS / 100 ST							
1/2 13	X	X	X					
5/8 16	X	X	X					
3/4 19	X	X	X	X	X			
7/8 22	X	X	X	X	X			
1" 25	X	X	X	X	X	X	X	
1 1/4 32	X	X	X	X	X	X	X	X
1 1/2 38	X	X	X	X	X	X	X	X
1 3/4 45	X	X	X	X	X	X	X	X
2" 51	X	X	X	X	X	X	X	X
2 1/4 57	X	X	X	X	X	X	X	X
2 1/2 64	X	X	X	X	X	X	X	X
2 3/4 70	X	X	X	X	X	X	X	X
3" 76	X	X	X	X	X	X	X	X
3 1/4 83	X	X	X	X	X	X	X	X
3 1/2 89		X	X	X	X	X	X	X
3 3/4 95								
4" 102	X	X	X	X	X	X	X	X
4 1/2 114		X	X		X	X	X	X
5" 127			X	X	X	X	X	X
5 1/2 140			X	X	X	X	X	X
6" 152			X	X	X	X	X	X
6 1/2 165								
7" 178								
7 1/2 191								
8" 203								
9" 229								
10" 254								
11" 279								
12" 305								

ÖVRIGA DIMENSIONER OCH LÄNGDER MOT FÖRFRÅGAN !

FÖRP.	1/4"	5/16"	3/8"	7/16"	1/2"	9/16"	5/8"	3/4"
200 ST	13-							
100 ST	102-	13-	13-	19-	19-			
50 ST		102-	64-	64-	32-	25-	25-	
25 ST			114-	127-	102-	76-	38-	38-
10 ST							102-	64-

BESTÄLLNINGSEXEMPEL: 11156081016 - U6S 5/16"UNCx16 8.8 FZB

SWEBOLT AB

TEL 08 - 584 909 60 FAX 08 - 583 581 82

ARTIKELLISTA
2013-2014
SEXKANTSKRUV
U6S 10.9 UNC ANSI B18.2.1
OBEHANDLAD

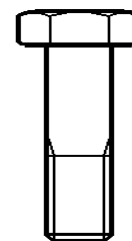

GÄNGA	1/4"	5/16"	3/8"	7/16"	1/2"	9/16"	5/8"	3/4"
Stigning	20	18	16	14	13	12	11	10
Nyckelv	7/16"	1/2"	9/16"	5/8"	3/4"	13/16"	15/16"	1 1/8"
Nyckelv	11.1	12.7	14.3	15.9	19	20.6	23.8	28.6
Skallh	4	5.2	6	7.1	7.9	9.1	9.9	11.9
Gängl	19	22	25	28	32	35	38	44
Längd (tum mm)	C:A PRIS / 100 ST							
1/2 13								
5/8 16								
3/4 19								
7/8 22				X				
1" 25					X		X	
1 1/4 32							X	
1 1/2 38								
1 3/4 45								
2" 51								
2 1/4 57								
2 1/2 64								X
2 3/4 70								
3" 76								
3 1/4 83								
3 1/2 89								
3 3/4 95								
4" 102								X
4 1/2 114								
5" 127								
5 1/2 140								
6" 152								
6 1/2 165								
7" 178								
7 1/2 191								
8" 203								
9" 229								
10" 254								
11" 279								
12" 305								

ÖVRIGA DIMENSIONER OCH LÄNGDER MOT FÖRFRÅGAN !

FÖRP.	1/4"	5/16"	3/8"	7/16"	1/2"	9/16"	5/8"	3/4"
200 ST	13-							
100 ST	102-	13-	13-	19-	19-			
50 ST		102-	64-	64-	32-	25-	25-	
25 ST			114-	127-	102-	76-	38-	38-
10 ST							102-	64-

BESTÄLLNINGSEXEMPEL: 11158127025 - U6S 1/2"UNCx25 10.9

ARTIKELLISTA

2013-2014

SEXKANTSKRUV FINGÄNGA FU6S 8.8 UNF ANSI B18.2.1 BLANKFÖRZINKAD

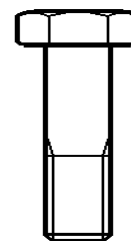

GÄNGA	1/4"	5/16"	3/8"	7/16"	1/2"	9/16"	5/8"	3/4"
Stigning	28	24	24	20	20	18	18	16
Nyckelv	7/16"	1/2"	9/16"	5/8"	3/4"	13/16"	15/16"	1 1/8"
Nyckelv	11.1	12.7	14.3	15.9	19	20.6	23.8	28.6
Skallh	4	5.2	6	7.1	7.9	9.1	9.9	11.9
Gängl	19	22	25	28	32	35	38	44
Längd (tum mm)	C:A PRIS / 100 ST							
1/2 13	X	X						
5/8 16	X	X						
3/4 19	X	X	X	X				
7/8 22	X	X	X	X				
1" 25	X	X	X	X	X			
1 1/4 32	X	X	X	X	X		X	
1 1/2 38	X	X	X	X	X		X	X
1 3/4 45	X	X	X	X	X		X	X
2" 51	X	X	X	X	X		X	X
2 1/4 57	X	X	X	X	X	X	X	X
2 1/2 64	X	X	X	X	X		X	X
2 3/4 70	X	X	X	X	X		X	X
3" 76	X	X	X	X	X		X	X
3 1/4 83	X	X	X	X	X		X	X
3 1/2 89	X	X	X	X	X		X	X
3 3/4 95								
4" 102	X	X	X	X	X		X	X
4 1/2 114		X	X	X	X		X	X
5" 127		X	X	X	X		X	X
5 1/2 140								
6" 152								
6 1/2 165								
7" 178								
7 1/2 191								
8" 203								
9" 229								
10" 254								
11" 279								
12" 305								

ÖVRIGA DIMENSIONER OCH LÄNGDER MOT FÖRFRÅGAN !

FÖRP.	1/4"	5/16"	3/8"	7/16"	1/2"	9/16"	5/8"	3/4"
200 ST	13-							
100 ST	102-	13-	13-	19-	19-			
50 ST		102-	64-	64-	32-	25-	25-	
25 ST			114-	127-	102-	76-	38-	38-
10 ST							102-	64-

BESTÄLLNINGSEXEMPEL: 111561065025 - FU6S 1/4UNFx25 8.8 FZB

SWEBOLT AB

TEL 08 - 555 975 00 FAX 08 - 583 581 82

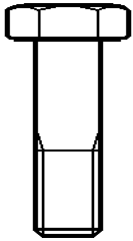

ARTIKELLISTA

2013-2014

SEXKANTSKRUV FINGÄNGA FU6S 10.9 UNF ANSI B18.2.1 OBEHANDLAD

GÄNGA	1/4"	5/16"	3/8"	7/16"	1/2"	9/16"	5/8"	3/4"
Stigning	28	24	24	20	20	18	18	16
Nyckelv	7/16"	1/2"	9/16"	5/8"	3/4"	13/16"	15/16"	1 1/8"
Nyckelv	11.1	12.7	14.3	15.9	19	20.6	23.8	28.6
Skallh	4	5.2	6	7.1	7.9	9.1	9.9	11.9
Gängl	19	22	25	28	32	35	38	44
Längd (tum mm)	C:A PRIS / 100 ST							
1/2 13	X	X						
5/8 16	X	X						
3/4 19	X	X	X	X				
7/8 22	X	X	X	X				
1" 25	X	X	X	X	X			
1 1/4 32	X	X	X	X	X		X	
1 1/2 38	X	X	X	X	X		X	X
1 3/4 45	X	X	X	X	X		X	X
2" 51	X	X	X	X	X		X	X
2 1/4 57	X	X	X	X	X		X	X
2 1/2 64	X	X	X	X	X		X	X
2 3/4 70	X	X	X	X	X		X	X
3" 76	X	X	X	X	X		X	X
3 1/4 83	X	X	X	X	X		X	X
3 1/2 89	X	X	X	X	X		X	X
3 3/4 95								
4" 102	X	X	X	X	X		X	X
4 1/2 114		X	X	X	X		X	X
5" 127		X	X	X	X		X	X
5 1/2 140								
6" 152								
6 1/2 165								
7" 178								
7 1/2 191								
8" 203								
9" 229								
10" 254								
11" 279								
12" 305								

ÖVRIGA DIMENSIONER OCH LÄNGDER MOT FÖRFRÅGAN !

FÖRP.	1/4"	5/16"	3/8"	7/16"	1/2"	9/16"	5/8"	3/4"
200 ST	13-							
100 ST	102-	13-	13-	19-	19-			
50 ST		102-	64-	64-	32-	25-	25-	
25 ST			114-	127-	102-	76-	38-	38-
10 ST							102-	64-

BESTÄLLNINGSEXEMPEL: 111631065025 - FU6S 1/4UNFx25 10.9 OBEH

SWEBOLT AB

TEL 08 - 555 975 00 FAX 08 - 583 581 82

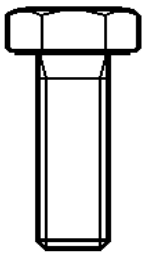

ARTIKELLISTA

2013-2014

HELGÄNGAD SEXKANTSKRUV

M6SH ISO 4017 / DIN 933

ROSTFRI A2

	ISO		DIN		ISO		DIN		ISO		DIN				
GÄNGA	M3	M4	M5	M6	M8	M10	M10	M12	M12	M14	M14	M16	M20	M24	
Nyckelv	5.5	7	8	10	13	16	17	18	19	21	22	24	27	30	
Skallh	2	2.8	3.5	4	5.3	6.4	6.4	7.5	7.5	9	9	10	12.5	15	
Längd	C:A PRIS/100 ST														
6	X	X	X												
8	X	X	X	X	X										
10	X	X	X	X	X		X								
12	X	X	X	X	X		X								
14	X	X	X	X	X		X								
16	X	X	X	X	X	X	X								
18	X	X	X	X	X		X								
20	X	X	X	X	X	X	X	X	X		X	X			
22	X	X	X	X	X										
25	X	X	X	X	X	X	X	X	X		X	X			
30	X	X	X	X	X	X	X	X	X		X	X	X		
35	X	X	X	X	X	X	X	X	X		X	X	X	X	
40	X	X	X	X	X	X	X	X	X		X	X	X	X	
45		X	X	X	X	X	X	X	X		X	X	X	X	
50		X	X	X	X	X	X	X	X		X	X	X	X	
55		X	X	X	X	X	X	X	X		X	X	X	X	
60		X	X	X	X	X	X	X	X		X	X	X	X	
65		X	X	X	X	X	X	X	X		X	X	X	X	
70		X	X	X	X	X	X	X	X		X	X	X	X	
75				X											
80		X	X	X	X	X	X	X	X		X	X	X	X	
90				X	X	X	X	X	X		X	X	X	X	
100				X	X	X	X	X	X		X	X	X	X	
110				X	X		X		X		X	X	X	X	
120				X	X		X		X		X	X	X	X	
130					X		X		X		X	X	X	X	
140					X		X		X		X	X	X	X	
150					X		X		X		X	X	X	X	
160					X		X		X			X	X	X	
180					X		X		X			X	X	X	

KRYSSMARKERADE ARTIKLAR MOT FÖRFRÅGAN !
ÖVRIGA DIMENSIONER OCH LÄNGDER MOT FÖRFRÅGAN !

FÖRP.	M3	M4	M5	M6	M8	M10	M10	M12	M12	M14	M14	M16	M20	M24
200 ST	6-	6-	6-	8-										
100 ST			35-	35-	8-	10-	10-	20-	20-					
50 ST					80-	60-	60-	25-	25-	20-	20-			
25 ST								120-	110-			40-	30-	
20 ST														35-
10 ST													120-	55-

BESTÄLLNINGSEXEMPEL: 2111006030 - M6SH M6x30 A2

SWEBOLT AB

TEL 08 - 555 975 00 FAX 08 - 583 581 82

ARTIKELLISTA
2013-2014
DELGÄNGAD SEXKANTSKRUV
M6S ISO 4014 / DIN 931
ROSTFRI A2

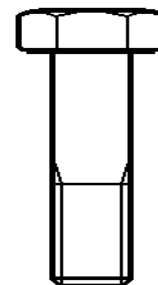

				ISO	DIN	ISO	DIN	ISO	DIN			
GÄNGA	M5	M6	M8	M10	M10	M12	M12	M14	M14	M16	M20	M24
Nyckelv	8	10	13	16	17	18	19	21	22	24	27	30
Skallh	3.5	4	5.3	6.4	6.4	7.5	7.5	9	9	10	12.5	15
Gängl	16	18	22	26	26	30	30	34	34	38	46	54
120 ->				32	32	36	36	40	40	44	52	60
200 ->								53	53	57	65	73

Längd	C:A PRIS/100 ST											
25	X											
30	X	X	X									
35	X	X	X		X							
40	X	X	X		X		X					
45	X	X	X		X		X					
50	X	X	X		X		X		X	X		
55	X	X	X		X		X		X	X		
60	X	X	X		X		X		X	X	X	
65	X	X	X		X		X		X	X	X	
70	X	X	X		X		X		X	X	X	X
75		X	X		x		X			X	X	X
80	X	X	X		X		X		X	X	X	X
90	X	X	X		X		X		X	X	X	X
100	X	X	X		X		X		X	X	X	X
110		X	X		X		X		X	X	X	X
120		X	X		X		X		X	X	X	X
130		X	X		X		X		X	X	X	X
140		X	X		X		X		X	X	X	X
150		X	X		X		X		X	X	X	X
160		X	X		X		X		X	X	X	X
170					X		X			X	X	X
180		X	X		X		X			X	X	X
190					X		X			X	X	X
200			X		X		X			X	X	X
220			X		X		X			X	X	X
240					X		X			X	X	X
250					X		X			X	X	X
260					X					X	X	X
280										X	X	X
300										X	X	X

KRYSSMARKERADE ARTIKLAR MOT FÖRFRÅGAN !
 ÖVRIGA DIMENSIONER OCH LÄNGDER MOT FÖRFRÅGAN !

FÖRP.	M5	M6	M8	M10	M10	M12	M12	M14	M14	M16	M20	M24
100 ST	25-	30-	30-		35-							
50 ST			80-		60-		40-		50-	50-	60-	
25 ST			140-		120-		110-			60-	70-	
20 ST										130-	110-	
10 ST										150-	120-	70-

BESTÄLLNINGSEXEMPEL: 2111016100 - M6S M16x100 A2

SWEBOLT AB
TEL 08 - 555 975 00 FAX 08 - 583 581 82

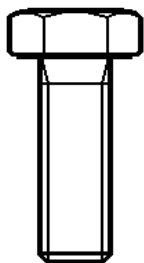

ARTIKELLISTA

2013-2014

HELGÄNGAD SEXKANTSKRUV

M6SH ISO 4017 / DIN 933

SYRAFAST A4-80 / A4-70

GÄNGA	ISO		DIN		ISO		DIN		ISO		DIN		A4-70	
	M4	M5	M6	M8	M10	M10	M12	M12	M14	M14	M16	M20	M24	M27
Nyckelv	7	8	10	13	16	17	18	19	21	22	24	27	30	41
Skallh	2.8	3.5	4	5.5	7	7	8	8	9	9	10	12	13	17
Längd	C:A PRIS/100 ST													
6	x	X	X											
8	X	X	X	X										
10	X	X	X	X		X								
12	X	X	X	X		X								
14	X	X	X	X										
16	X	X	X	X	X	X		X						
20	X	X	X	X	X	X	X	X		X	X			
22	X	X	X	X		X								
25	X	X	X	X	X	X	X	X		X	X			
30	X	X	X	X	X	X	X	X		X	X	X		
35	X	X	X	X	X	X	X	X		X	X	X		
40	X	X	X	X	X	X	X	X		X	X	X	X	
45	X	X	X	X	X	X	X	X		X	X	X	X	
50	X	X	X	X	X	X	X	X		X	X	X	X	X
55		X	X	X	X	X	X	X		X	X	X	X	X
60	X	X	X	X	X	X	X	X		X	X	X	X	X
65		X	X	X	X	X	X	X		X	X	X	X	X
70	X	X	X	X	X	X	X	X		X	X	X	X	X
75				X	X	X	X	X		X	X	X	X	X
80		X	X	X	X	X	X	X		X	X	X	X	X
90			X	X	X	X	X	X		X	X	X	X	X
100			X	X	X	X	X	X		X	X	X	X	X
110				X		X	X	X		X	X	X	X	X
120				X		X	X	X		X	X	X	X	X
130				X		X		X		X	X	X	X	X
140				X		X		X		X	X	X	X	X
150				X		X		x		X	X	X	X	X
160				X		X		X			X	X	X	

KRYSSMARKERADE ARTIKLAR MOT FÖRFRÅGAN !
ÖVRIGA DIMENSIONER OCH LÄNGDER MOT FÖRFRÅGAN !

FÖRP.	M4	M5	M6	M8	M10	M10	M12	M12	M14	M14	M16	M20	M24	M27
500 ST	6-	6-	6-											
200 ST	20-	20-	16-	8-										
100 ST	50-	45-	45-	40-		10-		16-						
50 ST				90-		60-		40-		20-	20-			
25 ST						120-		80-		55-	55-	30-		
20 ST												90-	40-	
10 ST													55-	
1 ST														50-

BESTÄLLNINGSEXEMPEL: 2112208050 - M6SH M8x50/50 A4-80

SWEBOLT AB

TEL 08 - 555 975 00 FAX 08 - 583 581 82

ARTIKELLISTA
2013-2014
DELGÄNGAD SEXKANTSKRUV
M6S ISO 4014 / DIN 931
SYRAFAST A4-80 / A4-70

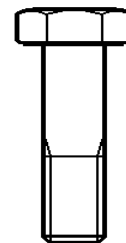

				ISO	DIN	ISO	DIN	ISO	DIN				A4-70	A4-70	A4-70
GÄNGA	M5	M6	M8	M10	M10	M12	M12	M14	M14	M16	M20	M24	M27	M30	M36
Nyckelv	8	10	13	16	17	18	19	21	22	24	27	30	41	46	55
Skallh	3.5	4	5.5	7	7	8	8	9	9	10	12	13	17	18.7	22.5
Gängl	16	18	22	26	26	30	30	34	34	38	42	46	60	66	78
120 ->				32	32	36	36	40	40	44	48	52	66	72	84
200 ->									53	57	61	65	79	85	97
Längd	C:A PRIS/100 ST														
25	X														
30	X	X	X												
35	X	X	X												
40	X	X	X	X	X										
45	X	X	X	X	X	X	X								
50	X	X	X	X	X	X	X		X	X					
55	X	X	X	X	X	X	X		X	X					
60	X	X	X	X	X	X	X		X	X	X				
65	X	X	X	X	X	X	X		X	X	X				
70	X	X	X	X	X	X	X		X	X	X	X			
75		X	X	X	X	X	X		X	X	X	X			
80	X	X	X	X	X	X	X		X	X	X	X			
90		X	X	X	X	X	X		X	X	X	X	X	X	
100		X	X	X	X	X	X		X	X	X	X	X	X	X
110		X	X	X	X	X	X		X	X	X	X	X	X	X
120		X	X	X	X	X	X		X	X	X	X	X	X	X
130		X	X		X		X		X	X	X	X	X	X	X
140		X	X		X		X		X	X	X	X	X	X	X
150		X	X		X		X		X	X	X	X	X	X	X
160		X	X		X		X		X	X	X	X	X	X	X
180		X	X		x		X		X	X	X	X	X	X	X
200		X	X		x		X		X	X	X	X	X	X	X
220					X		X			X	X	X	X	X	X
230					X		X			X	X	X	X	X	X
240					X		X			X	X	X	X	X	X
250					X		X			X	X	X	X	X	X
260										X	X	X	X	X	
280										X	X	X	X	X	
300										X	X	X	X	X	

KRYSSMARKERADE ARTIKLAR MOT FÖRFRÅGAN !
 ÖVRIGA DIMENSIONER OCH LÄNGDER MOT FÖRFRÅGAN !

FÖRP.	M5	M6	M8	M10	M10	M12	M12	M14	M14	M16	M20	M24	M27	M30	M36
100 ST	35-	35-	40-	40-											
50 ST		180-	110-	70-			45-		55-	55-					
25 ST			130-	130-			120-		110-	70-	70-				
20 ST										130-		80-			
10 ST											180-	90-			
1 ST										220-	220-	220-	90-	90-	100-

BESTÄLLNINGSEXEMPEL: 2111208080 - M6S M8x80 A4-80

SWEBOLT AB
TEL 08 - 555 975 00 FAX 08 - 583 581 82

ARTIKELLISTA
2013-2014
DELGÄNGAD SEXKANTSKRUV
M6S 8.8 DEPO ISO 4014
DELTA YTBEHANDLING

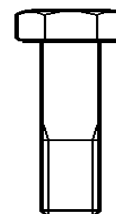

			ISO	ISO	ISO			
GÄNGA	M6	M8	M10	M12	M14	M16	M18	M20
Nyckelv	10	13	16	18	21	24	27	30
Skallh	4	5.3	6.4	7.5	8.8	10	11.5	12.5
Gängl	18	22	26	30	34	38	42	46
120-			32	36	40	44	48	52
200-			45	49	53	57	61	65
Längd	C:A PRIS / 100 ST							
30	X							
35	X	X						
40	X	X						
45	X	X						
50	X	X	X	X	X			
55	X	X	X	X	X	X		
60	X	X	X	X	X	X	X	X
65	X	X	X	X	X	X	X	X
70	X	X	X	X	X	X	X	X
75	X	X	X	X	X	X	X	X
80	X	X	X	X	X	X	X	X
90	X	X	X	X	X	X	X	X
100	X	X	X	X	X	X	X	X
110	X	X	X	X	X	X	X	X
120	X	X	X	X	X	X	X	X
130	X	X	X	X	X	X	X	X
140	X	X	X	X	X	X	X	X
150	X	X	X	X	X	X	X	X
160		X	X	X	X	X	X	X
180		X	X	X	X	X	X	X
200		X	X	X	X	X	X	X
220								
240								
260								
280								
300								

ÖVRIGA DIMENSIONER OCH LÄNGDER MOT FÖRFGÅRAN !

FÖRP.	M6	M8	M10	M12	M14	M16	M18	M20
200 ST	30-							
100 ST	70-	35-	40-					
50 ST		120-	60-	45-	50-			
25 ST			110-	100-	140-	60-	70-	70-
10 ST						220-	80-	100-







BESTÄLLNINGSEXEMPEL: 7111112100 - M6S M12X100 8.8 DEPO

INFORMATION

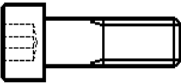
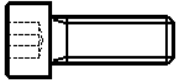
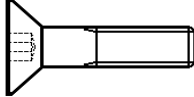
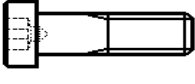
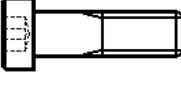
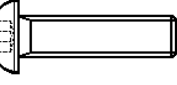
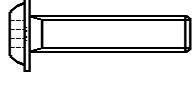
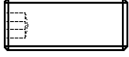
DEPO ÄR EN NY YTBEHANDLING SOM KLARAR SALTSPRAYTEST C:A 700 TIMMAR. DETTA ÄR ATT JÄMFÖRA MED VARMFÖRZINKAT 40MY.
 DESSUTOM HAR DENNA YTBEHANDLING INTE PROBLEMET MED KROM VI. DESSUTOM GÖR APPLICERINGSMETODEN ATT PROBLEMEN MED VÄTESPRÖDHET KAN MINIMERAS.
 DEPO ÄR EN ORGANISK YTBEHANDLING.

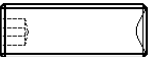
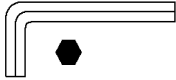
SWEBOLT AB

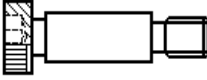
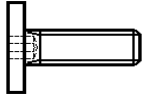
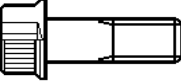
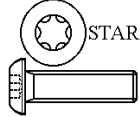
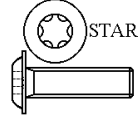
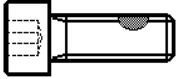
TEL 08 - 555 975 00 FAX 08 - 583 581 82

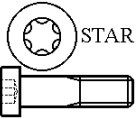
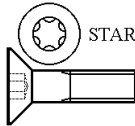
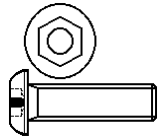
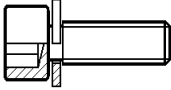
- 1 - 	- 2 - 	- 3 - 	- 4 - 
- 5 - 	- 6 - 	- 7 - 	- 8 - 
- 9 - 	- 10 - 	- 11 - 	- 12 - 
- 13 - 	- 14 -  ★ STAR	- 15 - 	- 16 - 
- 17 - 	- 18 -  ★ STAR	- 19 -  ★ STAR	- 20 - 
- 21 - 	- 22 -  ★ STAR	- 23 -  ★ STAR	- 24 - 
- 25 - 	- 26 -	- 27 -	- 28 -
- 29 -	- 30 -	- 31 -	- 32 -

SWEBOLT AB

TEL. 08-584 90960 FAX. 08-583 581 82

PRODUKTER I STÅL

1-2	12000	MC6S, INSEXSKRUV	912	4762	8.8	OBEH	2:1-2
1-2	12001	MC6S, INSEXSKRUV	912	4762	8.8	FZB	2:3-4
1-2	72002	MC6S, INSEXSKRUV	912	4762	8.8	DEPO	2:7
2	12003	MC6SH, INSEXSKRUV, HELG.	912	4762	8.8	OBEH	2:8
2	12004	MC6SH, INSEXSKRUV, HELG.	912	4762	8.8	FZB	2:8
1-2	12007	MC6S, INSEXSKRUV	912	4762	10.9	OBEH	2:10
1-2	12008	MC6S, INSEXSKRUV	912	4762	10.9	FZB/DEPO	2:11
1-2	72009	MC6S, INSEXSKRUV	912	4762	10.9	DACROMET	2:11
1-2	12005	MC6S, INSEXSKRUV	912	4762	12.9	OBEH	2:5-6
2	12006	MC6SH, INSEXSKRUV, HELG.	912	4762	12.9	OBEH	2:12
1-2	12010	MC6S, INSEXSKRUV	912	4762	12.9	DEPO	2:12
1-2	12013	FMC6S, INSEXSKRUV, FING.	912	4762	8.8	OBEH	2:9
1-2	12014	FMC6S, INSEXSKRUV, FING.	912	4762	8.8	FZB	2:9
1-2	12015	FMC6S, INSEXSKRUV, FING.	912	4762	12.9	OBEH	2:12
2	12016	UC6S, INSEXSKRUV, SERIE 1960	UNC		8.8	FZB	2:43
2	12017	UC6S, INSEXSKRUV, SERIE 1960	UNC		12.9	OBEH	2:44
1-2	12018	ULC6S, INSEXSKRUV SERIE 1936	UNC		12.9	OBEH	2:44
1-2	12019	FUC6S, INSEXSKRUV	UNF		12.9	OBEH	2:45
1-2	12020	EC6S, INSEXSKRUV	WITHW+BSF		12.9	OBEH	2:45
22	12021	MCTS, INSEXSKRUV STAR	~912	~4762	8.8	OBEH	2:54
22	12022	MCTS, INSEXSKRUV STAR	~912	~4762	8.8	FZB	2:55
22	12023	MCTS, INSEXSKRUV STAR	~912	~4762	10.9	OBEH	2:54
22	12024	MCTS, INSEXSKRUV STAR	~912	~4762	10.9	FZB/DEPO	2:55
3	12030	MF6S, FÖRSÄNKT INSEXSKRUV	7991	10642	8.8	OBEH	2:15
3	12033	MF6S, FÖRSÄNKT INSEXSKRUV	7991	10642	8.8	FZB	2:16
3	12031	MF6S, FÖRSÄNKT INSEXSKRUV	7991	10642	10.9	OBEH	2:13
3	12032	MF6S, FÖRSÄNKT INSEXSKRUV	7991	10642	10.9	FZB	2:14
3	12034	MF6S, FÖRSÄNKT INSEXSKRUV	7991	10642	10.9	DEPO	2:14
3	12029	MF6SH, HELGÄNGAD FÖRSÄNKT	7991	10642	10.9	FZB	
23	12215	MFTS, FÖRS. INSEXS. m. STAR	~7991	~10642	8.8	OBEH	2:40
23	12216	MFTS, FÖRS. INSEXS. m. STAR	~7991	~10642	8.8	FZB	2:40
3	12035	UF6S, FÖRSÄNKT INSEXSKRUV	UNC		10.9	OBEH	2:46
3	72036	UF6S, FÖRSÄNKT INSEXSKRUV	UNC		10.9	FZB/DEPO	2:46
3	12038	FUF6S, FÖRSÄNKT INSEXSKRUV	UNF		10.9	OBEH	2:46
3	12040	WF6S, FÖRSÄNKT INSEXSKRUV	WITHW+BSF		10.9	OBEH	2:46
5	12060	MLC6S, LÅG INSEXSKRUV	7984		8.8	OBEH	2:17
5	12061	MLC6S, LÅG INSEXSKRUV	7984		8.8	FZB	2:18
5	12062	MLC6S, LÅG INSEXSKRUV	7984		10.9	OBEH	2:21
5	72063	MLC6S, LÅG INSEXSKRUV	7984		10.9	FZB/DEPO	2:22
5	12067	MLC6S, LÅG INSEXSKRUV	7984		12.9	OBEH	2:21
5	72068	MLC6S, LÅG INSEXSKRUV	7984		12.9	DEPO	2:22
5	12065	FULC6S, LÅG INSEXSKRUV	UNF		12.9	OBEH	2:47
5	12066	ULC6S, LÅG INSEXSKRUV	UNC		12.9	OBEH	2:48

SWEBOLT AB

TEL. 08-584 909 60 FAX. 08-583 581 82

BILD	ART.GR.	BENÄMNING	DIN	ISO	KVAL	YTBEH	SIDA
22	12210	MLCTS, LÅG SKALLE STAR	~7984		8.8	OBEH	2:39
22	12211	MLCTS, LÅG SKALLE STAR	~7984		8.8	FZB	2:39
4	12050	MLC6SE, LÅG INSEXSKRUV	6912		8.8	OBEH	2:19
4	12051	MLC6SE, LÅG INSEXSKRUV	6912		8.8	FZB	2:20
4	12055	MLC6SE, LÅG INSEXSKRUV	6912		10.9	OBEH	2:19
4	72056	MLC6SE, LÅG INSEXSKRUV	6912		10.9	FZB/DEPO	2:20
6	12070	K6S, KULLRIG INSEXSKRUV		7380	10.9	OBEH	2:23
6	12071	K6S, KULLRIG INSEXSKRUV		7380	10.9	FZB	2:24
6	12075	UK6S, KULLRIG INSEXSKRUV	UNC		10.9	OBEH	2:48
6	12077	FUK6S, KULLRIG INSEXSKRUV	UNF		10.9	OBEH	2:48
18	12190	KTS, KULLRIG MED STAR		~7380	10.9	OBEH	2:37
18	12191	KTS, KULLRIG MED STAR		~7380	10.9	FZB	2:37
7	12072	K6SF, KULLRIG INSEXS. m. FLÄNS			10.9	OBEH	2:25
7	12073	K6SF, KULLRIG INSEXS. m. FLÄNS			10.9	FZB	2:26
19	12195	KTSE, KULLRIG STAR m. FLÄNS			10.9	OBEH	2:38
19	12196	KTSE, KULLRIG STAR m. FLÄNS			10.9	FZB	2:38
8	12080	P6SS, STOPPSKRUV PLAN	913	4026	45HRC	OBEH	2:27
8	12081	P6SS, STOPPSKRUV PLAN	913	4026	45HRC	FZB/DEPO	2:29
8	12082	FP6SS, STOPPSKRUV PLAN FING.	913	4026	45HRC	OBEH	2:29
8	12085	UP6SS, STOPPSKRUV PLAN	UNC		45HRC	OBEH	2:49
8	12087	FUP6SS, STOPPSKRUV PLAN	UNF		45HRC	OBEH	2:50
9	12090	S6SS, STOPPSKRUV SPETS	914	4027	45HRC	OBEH	2:27
9	12091	S6SS, STOPPSKRUV SPETS	914	4027	45HRC	FZB/DEPO	2:29
9	12092	FS6SS, STOPPSKRUV SPETS FING.	914	4027	45HRC	OBEH	2:29
9	12095	US6SS, STOPPSKRUV SPETS	UNC		45HRC	OBEH	2:49
9	12097	FUS6SS, STOPPS. SPETS	UNF		45HRC	OBEH	2:50
10	12100	T6SS, STOPPSKRUV TAPP	915	4028	45HRC	OBEH	2:28
10	12101	T6SS, STOPPSKRUV TAPP	915	4028	45HRC	FZB/DEPO	2:30
10	12102	FT6SS, STOPPSKRUV TAPP FING.	915	4028	45HRC	OBEH	2:29
10	12105	UT6SS, STOPPSKRUV TAPP	UNC		45HRC	OBEH	2:49
10	12107	FUT6SS, STOPPSKRUV TAPP	UNF		45HRC	OBEH	2:50
11	12110	SK6SS, STOPPSKRUV SKÅLAD	916	4029	45HRC	OBEH	2:28
11	12111	SK6SS, STOPPSKRUV SKÅLAD	916	4029	45HRC	FZB/DEPO	2:30
11	12114	FSK6SS, STOPPSK SKÅLAD, FING.	916	4029	45HRC	OBEH	2:29
11	12115	USK6SS, STOPPSKRUV SKÅLAD	UNC		45HRC	OBEH	2:49
11	12117	FUSK6SS, STOPPSK. SKÅLAD	UNF		45HRC	OBEH	2:50
11	12120	RSK6SS, STOPPSKRUV SKÅLAD	RÖRG.			OBEH	2:51

SWEBOLT AB

TEL. 08-584 909 60 FAX. 08-583 581 82

BILD	ART.GR.	BENÄMNING	DIN	ISO	KVAL	YTBEH	SIDA
12	12130	6KN, 6-KANT-NYCKEL	911	2936		OBEH	2:31
12	12131	6KN, 6-KANT-NYCKEL	911	2936		FZB	2:31
12	12132	6KN, 6-KANT-NYCKEL	911		HÄRDAD	OBEH	2:31
12	12133	6KN, 6-KANT-NYCKEL	911		HÄRDAD	FZB	2:31
12	12134	6KN, 6-KANT-NYCKEL, LÅNG	911			OBEH	2:31
12	12135	6KN, 6-KANT-NYCKEL, LÅNG	911			FZB	2:31
12	12136	6KN, 6-KANT-NYCKEL m. INV HÅL för SÄKERHETSSKRUV	~911	2936		STÅL	2:32
13	12140	6-KANT-NYCKEL m. TAPP	6911			OBEH	2:32
13	12141	6-KANT-NYCKEL m. TAPP	6911			FZB	2:32
14	12150	STAR-NYCKEL, TORX				OBEH	2:32
14	12151	STAR-NYCKEL, TORX				FZB	2:32
15	12160	MC6SPB, PASSBULT ANSATSSKRUV		7379	12.9	OBEH	2:33
16	12170	MLC6SS, LÅG STOR SKALLE, INSEX			10.9	OBEH	2:34
16	12171	MLC6SS, LÅG STOR SKALLE, INSEX			10.9	FZB	2:34
17	12180	MC6SF, INSEXSKRUV m. FLÄNS			12.9	OBEH	2:35
17	12181	MC6SF, INSEXSKRUV m. FLÄNS			12.9	FZB	2:35
17	12175	MC6SFT, INSEXSKRUV m. TENSILÖCK			100	OBEH	2:36
20	12200	INSEXSKRUV ESLOK + ÖVRIGA LÅSNINGAR				OBEH	2:52
20	12201	INSEXSKRUV ÖVRIGA LÅSNINGAR				FZB	2:52
21	12050	STOPPSKRUV ESLOK, PLAN	913	4026		OBEH	2:53
21	12052	STOPPSKRUV ESLOK, SPETS	914	4027		OBEH	2:53
21	12054	STOPPSKRUV ESLOK, TAPP	915	4028		OBEH	2:53
21	12056	STOPPSKRUV ESLOK, SKÅL	916	4029		OBEH	2:53
24	12073	SK6S, SÄKERHETSSKRUV m. INV TAPP		~7380	10.9	OBEH	2:41

ROSTFRITT / SYRAFAST

1-2	22000	MC6S, INSEXSKRUV	912	4762	A2		2:61
1-2	22001	MC6S, INSEXSKRUV	912	4762	A4		2:64
2	22003	MC6SH, HELGÄNGA	912	4762	A2		2:63
2	22004	MC6SH, HELGÄNGA	912	4762	A4		2:63
1-2	22005	MC6S, INSEXSKRUV	912	4762	A4-80		2:62
1-2	22010	UC6S, INSEXSKRUV	UNC		A2		2:78
1-2	22011	UC6S, INSEXSKRUV	UNC		A4		2:79
1-2	22012	FUC6S, INSEXSKRUV	UNF		A2		2:78
1-2	22013	FUC6S, INSEXSKRUV	UNF		A4		2:79
1-2	22014	MC6S, INSEXSKRUV	912	4762	A2	FÖRZINKAD	2:65
1-2	22015	MC6S, INSEXSKRUV	912	4762	A4	FÖRZINKAD	2:66
3	22030	MF6S, FÖRSÄNKAT INSEXSKRUV	7991	10642	A2		2:67
3	22031	MF6S, FÖRSÄNKAT INSEXSKRUV	7991	10642	A4		2:68
4	22050	MLC6SE, LÅG INSEXSKRUV	6912		A2		2:69
4	22051	MLC6SE, LÅG INSEXSKRUV	6912		A4		2:69

SWEBOLT AB

TEL. 08-584 909 60 FAX. 08-583 581 82

BILD	ART.GR.	BENÄMNING	DIN	ISO	KVAL	YTBEH	SIDA
5	22060	MLC6S, LÅG INSEXSKRUV	7984		A2		2:70
5	22061	MLC6S, LÅG INSEXSKRUV	7984		A4		2:70
6	22070	K6S, KULLRIG INSEXSKRUV		7380	A2		2:71
6	22071	K6S, KULLRIG INSEXSKRUV		7380	A4		2:71
7	22072	K6SF, KULLRING INSEX m. FLÄNS			A2		2:72
7	22073	K6SF, KULLRING INSEX m. FLÄNS			A4		2:72
8	22080	P6SS, STOPPSKRUV PLAN	913	4026	A2		2:73
8	22081	P6SS, STOPPSKRUV PLAN	913	4026	A4		2:74
8	22082	FP6SS, STOPPSKRUV PLAN, FING.	913	4026	A2		2:81
8	22083	FP6SS, STOPPSKRUV PLAN, FING.	913	4026	A4		2:81
9	22090	S6SS, STOPPSKRUV SPETS	914	4027	A2		2:73
9	22091	S6SS, STOPPSKRUV SPETS	914	4027	A4		2:74
9	22092	FS6SS, STOPPSKRUV SPETS, FING.	914	4027	A2		2:82
9	22093	FS6SS, STOPPSKRUV SPETS, FING.	914	4027	A4		2:82
10	22100	T6SS, STOPPSKRUV TAPP	915	4028	A2		2:73
10	22101	T6SS, STOPPSKRUV TAPP	915	4028	A4		2:74
10	22102	FT6SS, STOPPSKRUV TAPP, FING.	915	4028	A2		2:83
10	22103	FT6SS, STOPPSKRUV TAPP, FING.	915	4028	A4		2:83
11	22110	SK6SS, STOPPSKRUV SKÅLAD	916	4029	A2		2:73
11	22111	SK6SS, STOPPSKRUV SKÅLAD	916	4029	A4		2:74
11	22114	FSK6SS, STOPPSK. SKÅLAD, FING.	916	4029	A2		2:84
11	22115	FSK6SS, STOPPSK. SKÅLAD, FING.	916	4029	A4		2:84
11	22116	USK6SS, STOPPSKRUV SKÅLAD	UNC		A4		2:80
15	22160	MC6SPB, PASSBULT		~7379	A2		2:75
24	22074	SK6S, SÄKERHETSSKRUV m. INV TAPP		~7380	A2		2:76
25	22220	MC6SB, INSEX m. BRICKA	6900		A2		2:77

POLYAMID

1-2	42000	MC6S, INSEXSKRUV	912	4762			2:90
-----	-------	------------------	-----	------	--	--	------

SWEBOLT AB

TEL. 08-584 909 60 FAX. 08-583 581 82



ARTIKELLISTA
2013-2014
INSEXSKRUV
MC6S 8.8 DIN 912 / ISO 4762
OBEHANDLAD

GÄNGA	M3	M4	M5	M6	M8	M10	M12
Ytterd	5.5	7	8.5	10	13	16	18
Insex	2.5	3	4	5	6	8	10
Skallh	3	4	5	6	8	10	12
Gängl	18	20	22	24	28	32	36
Längd	C:A PRIS/100 ST						
4	X	X	X	X	X	X	X
5	X	X	X	X	X	X	X
6	X	X	X	X	X	X	X
8	X	X	X	X	X	X	X
10	X	X	X	X	X	X	X
12	X	X	X	X	X	X	X
14	X	X	X	X	X	X	X
16	X	X	X	X	X	X	X
18	X	X	X	X	X	X	X
20	X	X	X	X	X	X	X
22	X	X	X	X	X	X	X
25	X	X	X	X	X	X	X
30	X	X	X	X	X	X	X
35	X	X	X	X	X	X	X
40	X	X	X	X	X	X	X
45	X	X	X	X	X	X	X
50		X	X	X	X	X	X
55		X	X	X	X	X	X
60		X	X	X	X	X	X
65		X	X	X	X	X	X
70		X	X	X	X	X	X
75			X	X	X	X	X
80		X	X	X	X	X	X
90			X	X	X	X	X
100			X	X	X	X	X
110			X	X	X	X	X
120			X	X	X	X	X
130			X	X	X	X	X
140			X	X	X	X	X
150			X	X	X	X	X
160			X	X	X	X	X
180			X	X	X	X	X
200			X	X	X	X	X
220				X	X	X	X
240					X	X	X
260					X	X	X
280					X	X	X
300					X	X	X
320						X	X
340						X	X
360						X	X
380						X	X

KRYSSMARKERADE ARTIKLAR MOT FÖRFRÅGAN !
 ÖVRIGA DIMENSIONER OCH LÄNGDER MOT FÖRFRÅGAN !

FORP.	M3	M4	M5	M6	M8	M10	M12
500 ST	5-	5-	6-				
200 ST	8-	8-	8-	6-			
100 ST			110-	110-	8-	12-	16-
50 ST					140-	80-	60-
25 ST						160-	160-

BESTÄLLNINGSEXEMPEL: 1200108020 - MC6S M8x20 8.8 FZB

SWEBOLT AB

TEL 08-555 975 00 FAX 08-583 581 82

ARTIKELLISTA
2013-2014
INSEXSKRUV
MC6S 8.8 DIN 912 / ISO 4762
OBEHANDLAD



GÅNGA	M14	M16	M18	M20	M22	M24	M30	M36
Ytterd	21	24	27	30	33	36	45	54
Insex	12	14	14	17	17	19	22	27
Skallh	14	16	18	20	22	24	30	36
Gängl	40	44	48	52	56	60	72	84
Längd	C:A PRIS/100 ST							
16	X	X						
20	X	X						
25	X	X						
30	X	X	X	X				
35	X	X	X	X				
40	X	X	X	X	X	X		
45	X	X	X	X	X	X		
50	X	X	X	X	X	X	X	
55	X	X	X	X	X	X	X	
60	X	X	X	X	X	X	X	X
65	X	X	X	X	X	X	X	X
70	X	X	X	X	X	X	X	X
75	X	X	X	X	X	X	X	X
80	X	X	X	X	X	X	X	X
90	X	X	X	X	X	X	X	X
100	X	X	X	X	X	X	X	X
110	X	X	X	X	X	X	X	X
120	X	X	X	X	X	X	X	X
130	X	X	X	X	X	X	X	X
140	X	X	X	X	X	X	X	X
150	X	X	X	X	X	X	X	X
160	X	X	X	X	X	X	X	X
180	X	X	X	X	X	X	X	X
200	X	X	X	X	X	X	X	X
220	X	X	X	X	X	X	X	X
240		X	X	X	X	X	X	X
260		X	X	X	X	X	X	X
280		X	X	X	X	X	X	X
300		X	X	X	X	X	X	X
320		X		X		X	X	X
340		X		X		X	X	X
360		X		X		X	X	X
380		X		X		X	X	X
400		X		X		X	X	X
420							X	X

KRYSSMARKERADE ARTIKLAR MOT FÖRFRÅGAN !
 ÖVRIGA DIMENSIONER OCH LÄNGDER MOT FÖRFRÅGAN !

FÖRP.	M14	M16	M18	M20	M22	M24	M30	M36
100 ST	20-							
50 ST	40-	16-	40-					
25 ST	80-	40-	50-	30-	50-	40-		
10 ST		130-	220-	80-	100-	50-	60-	60-

BESTÄLLNINGSEXEMPEL: 1200120180 - MC6S M20x180 8.8 FZB

SWEBOLT AB
TEL 08-555 975 00 FAX 08-583 581 82



ARTIKELLISTA
2013-2014
INSEXSKRUV
MC6S 8.8 DIN 912 / ISO 4762
BLANKFÖRZINKAD

GÄNGA	M3	M4	M5	M6	M8	M10	M12
Ytterd	5.5	7	8.5	10	13	16	18
Insex	2.5	3	4	5	6	8	10
Skallh	3	4	5	6	8	10	12
Gängl	18	20	22	24	28	32	36
Längd	C:A PRIS/100 ST						
4	X						
5	X	X					
6	X	X	X	X			
8	X	X	X	X	X		
10	X	X	X	X	X	X	
12	X	X	X	X	X	X	
14	X	X	X	X	X	X	
16	X	X	X	X	X	X	X
18	X	X	X	X	X	X	
20	X	X	X	X	X	X	X
22	X	X	X	X	X	X	X
25	X	X	X	X	X	X	X
30	X	X	X	X	X	X	X
35	X	X	X	X	X	X	X
40	X	X	X	X	X	X	X
45	X	X	X	X	X	X	X
50		X	X	X	X	X	X
55		X	X	X	X	X	X
60		X	X	X	X	X	X
65		X	X	X	X	X	X
70		X	X	X	X	X	X
75			X	X	X	X	X
80		X	X	X	X	X	X
90			X	X	X	X	X
100		X	X	X	X	X	X
110			X	X	X	X	X
120			X	X	X	X	X
130			X	X	X	X	X
140			X	X	X	X	X
150			X	X	X	X	X
160			X	X	X	X	X
180			X	X	X	X	X
200			X	X	X	X	X
220				X	X	X	X
240					X	X	X
260					X	X	X
280					X	X	X
300					X	X	X
320						X	X
340						X	X
360						X	X
380						X	X

KRYSSMARKERADE ARTIKLAR MOT FÖRFRÅGAN !
 ÖVRIGA DIMENSIONER OCH LÄNGDER MOT FÖRFRÅGAN !

FORP.	M3	M4	M5	M6	M8	M10	M12
500 ST	5-	5-	6-				
200 ST	8-	8-	8-	6-			
100 ST			110-	110-	8-	12-	16-
50 ST					140-	80-	60-
25 ST						160-	160-

BESTÄLLNINGSEXEMPEL: 1200108020 - MC6S M8x20 8.8 FZB

SWEBOLT AB

TEL 08-555 975 00 FAX 08-583 581 82

ARTIKELLISTA
2013-2014
INSEXSKRUV
MC6S 8.8 DIN 912 / ISO 4762
BLANKFÖRZINKAD



GÅNGA	M14	M16	M18	M20	M22	M24	M30
Ytterd	21	24	27	30	33	36	45
Insex	12	14	14	17	17	19	22
Skallh	14	16	18	20	22	24	30
Gängl	40	44	48	52	56	60	72
Längd	C:A PRIS/100 ST						
16		X					
20	X	X					
25	X	X					
30	X	X	X	X			
35	X	X	X	X			
40	X	X	X	X		X	
45	X	X	X	X		X	
50	X	X	X	X	X	X	
55	X	X	X	X	X	X	
60	X	X	X	X	X	X	X
65	X	X	X	X	X	X	X
70	X	X	X	X	X	X	X
75	X	X	X	X	X	X	X
80	X	X	X	X	X	X	X
90	X	X	X	X	X	X	X
100	X	X	X	X	X	X	X
110	X	X	X	X	X	X	X
120	X	X	X	X	X	X	X
130	X	X	X	X	X	X	X
140	X	X	X	X	X	X	X
150	X	X	X	X	X	X	X
160	X	X	X	X	X	X	X
180	X	X	X	X	X	X	X
200	X	X	X	X	X	X	X
220	X	X	X	X	X	X	X
240	X	X	X	X	X	X	X
260	X	X	X	X	X	X	X
280	X	X	X	X	X	X	X
300	X	X	X	X	X	X	X
320	X	X		X		X	X
340	X	X		X		X	X
360	X	X		X		X	X
380	X	X		X		X	X
400	X	X		X		X	X
420							X

KRYSSMARKERADE ARTIKLAR MOT FÖRFRÅGAN !
 ÖVRIGA DIMENSIONER OCH LÄNGDER MOT FÖRFRÅGAN !

FÖRP.	M14	M16	M18	M20	M22	M24	M30
100 ST	20-						
50 ST	40-	16-	40-				
25 ST	80-	40-	50-	30-	50-	40-	
10 ST		130-	220-	80-	100-	50-	70-

BESTÄLLNINGSEXEMPEL: 1200120180 - MC6S M20x180 8.8 FZB

SWEBOLT AB
TEL 08-555 975 00 FAX 08-583 581 82



ARTIKELLISTA
2013-2014
INSEXSKRUV
MC6S 12.9 DIN 912 / ISO 4762
OBEHANDLAD

GÅNGA	M2	M2.5	M3	M4	M5	M6	M8	M10	M12	M14	M16	M18
Ytterd	3.8	4.5	5.5	7	8.5	10	13	16	18	21	24	57
Insex	1.5	2	2.5	3	4	5	6	8	10	12	14	14
Skallh	2	2.5	3	4	5	6	8	10	12	14	16	18
Gängl	16	17	18	20	22	24	28	32	36	40	44	48
Längd	C:A PRIS/100 ST											
3	X	X										
4	X	X	X									
5	X	X	X	X								
6	X	X	X	X	X	X						
8	X	X	X	X	X	X	X					
10	X	X	X	X	X	X	X	X				
12	X	X	X	X	X	X	X	X	X			
14			X	X	X	X	X	X				
16	X	X	X	X	X	X	X	X	X			
18			X	X	X	X	X	X	X			
20	X	X	X	X	X	X	X	X	X	X	X	
22			X	X	X	X	X	X	X	X	X	
25		X	X	X	X	X	X	X	X	X	X	
30			X	X	X	X	X	X	X	X	X	X
35			X	X	X	X	X	X	X	X	X	X
40			X	X	X	X	X	X	X	X	X	X
45			X	X	X	X	X	X	X	X	X	X
50			X	X	X	X	X	X	X	X	X	X
55			X	X	X	X	X	X	X	X	X	X
60			X	X	X	X	X	X	X	X	X	X
65				X	X	X	X	X	X	X	X	X
70				X	X	X	X	X	X	X	X	X
75				X	X	X	X	X	X	X	X	X
80				X	X	X	X	X	X	X	X	X
85											X	
90				X	X	X	X	X	X	X	X	X
95											X	
100				X	X	X	X	X	X	X	X	X
110				X	X	X	X	X	X	X	X	X
120				X	X	X	X	X	X	X	X	X
130					X	X	X	X	X	X	X	X
140					X	X	X	X	X	X	X	X
150					X	X	X	X	X	X	X	X
160					X	X	X	X	X	X	X	X
170					X				X			
180					X	X	X	X	X	X	X	X
200					X	X	X	X	X	X	X	X
220					X	X	X	X	X	X	X	X
240					X	X	X	X	X	X	X	X
260						X	X	X	X	X	X	X
280						X	X	X	X	X	X	X
300						X	X	X	X	X	X	X
320								X	X	X	X	X
340								X	X	X	X	X
360								X	X	X	X	X

KRYSSMARKERADE ARTIKLAR MOT FÖRFRÅGAN !
 ÖVRIGA DIMENSIONER OCH LÄNGDER MOT FÖRFRÅGAN !

FÖRP.	M2	M2.5	M3	M4	M5	M6	M8	M10	M12	M14	M16	M18
200 ST	3-	4-	4-	5-	6-	6-						
100 ST				100-	90-	80-	10-	10-	12-	20-		
50 ST							140-	75-	45-	35-	20-	30-
25 ST								180-	160-	80-	40-	60-
10 ST											110-	70-

BESTÄLLNINGSEXEMPEL: 1200508020 - MC6S M8x20 12.9

ARTIKELLISTA
2013-2014
INSEXSKRUV
MC6S 12.9 DIN 912 / ISO 4762
OBEHANDLAD



GÄNGA	M20	M22	M24	M27	M30	M33	M36	M39	M42	M45	M48
Ytterd	30	33	36	40	45	50	54	58	63		72
Insex	17	17	19	19	22	24	27	27	32		36
Skallh	20	22	24	27	30	33	36	39	42	45	48
Gängl	52	56	60	66	72	78	84	98	96		108
Längd	C:A PRIS/100 ST										
25											
30	X										
35	X										
40	X	X	X								
45	X	X	X								
50	X	X	X	X	X						
55	X	X	X	X	X						
60	X	X	X	X	X		X				
65	X	X	X	X	X						
70	X	X	X	X	X	X	X	X	X	X	
75	X	X	X	X	X						
80	X	X	X	X	X	X	X	X	X	X	X
90	X	X	X	X	X	X	X	X	X	X	X
100	X	X	X	X	X	X	X	X	X	X	X
110	X	X	X	X	X	X	X	X	X	X	X
120	X	X	X	X	X	X	X	X	X	X	X
130	X	X	X	X	X	X	X	X	X	X	X
140	X	X	X	X	X	X	X	X	X	X	X
150	X	X	X	X	X	X	X	X	X	X	X
160	X	X	X	X	X	X	X	X	X	X	X
180	X	X	X	X	X	X	X	X	X	X	X
200	X	X	X	X	X	X	X	X	X	X	X
220	X	X	X	X	X	X	X	X	X	X	X
240	X	X	X	X	X	X	X	X	X	X	X
260	X	X	X	X	X	X	X	X	X	X	X
280	X	X	X	X	X	X	X	X	X	X	X
300	X	X	X	X	X	X	X	X	X	X	X
320	X	X	X	X	X	X	X	X	X	X	X
340	X	X	X	X	X	X	X	X	X	X	X
360	X	X	X	X	X	X	X	X	X	X	X
380	X	X	X	X	X	X	X	X	X	X	X
400	X	X	X	X	X	X	X	X	X	X	X

KRYSSMARKERADE ARTIKLAR MOT FÖRFRÅGAN !
 ÖVRIGA DIMENSIONER OCH LÄNGDER MOT FÖRFRÅGAN !

FÖRP.	M20	M22	M24	M27	M30	M33	M36	M39	M42	M45	M48
25 ST	30-	40-	40-								
10 ST	60-	90-	50-	50-	60-	70-	70-				
5 ST	260-	260-	260-	200-	170-	160-	160-	70-	70-	70-	70-

BESTÄLLNINGSEXEMPEL: 1200524100 - MC6S M24X100 12.9

SWEBOLT AB
 TEL 08-555 975 00 FAX 08-583 581 82

ARTIKELLISTA
2013-2014
INSEXSKRUV
MC6S 12.9 DIN 912 / ISO 4762
OBEHANDLAD



GÄNGA	M3	M4	M5	M6	M8	M10	M12	M14	M16	M20	M24
Ytterd	5.5	7	8.5	10	13	16	18	21	24	30	36
Insex	2.5	3	4	5	6	8	10	12	14	17	19
Skallh	3	4	5	6	8	10	12	14	16	20	24
Längd	C:A PRIS/100 ST										
22	X										
25											
30											
35			X	X							
40					X						
45											
50				X	X	X					
55				X							
60					X		X				
65						X					
70				X	X	X	X		X		
75											
80				X		X	X		X		
90						X	X				
100					X	X	X		X		
110											
120						X	X				
130											
140											
150											
160											
180											
200											
220											
240											
260											
280											

KRYSSMARKERADE ARTIKLAR MOT FÖRFRÅGAN !
 ÖVRIGA DIMENSIONER OCH LÄNGDER MOT FÖRFRÅGAN !

FÖRP.	M3	M4	M5	M6	M8	M10	M12	M14	M16	M20	M24
200 ST											
100 ST											
50 ST											

BESTÄLLNINGSEXEMPEL: 1200606050 - MC6SH M6X50 12.9



ARTIKELLISTA
2013-2014
FÖRSÄNKT INSEXSKRUV
MF6S 10.9 DIN 7991
OBEHANDLAD

GÅNGA	M3	M4	M5	M6	M8	M10	M12	M14	M16	M20	M24
Ytterd	6	8	10	12	16	20	24	27	30	36	39
Insex	2	2.5	3	4	5	6	8	10	10	12	14
Skallh	1.7	2.3	2.8	3.3	4.4	5.5	6.5	13	7.5	8.5	14
Gängl	12	14	16	18	22	26	30	34	38	46	54
Längd	C:A PRIS/100 ST										
6	X	X									
8	X	X	X	X							
10	X	X	X	X	X						
12	X	X	X	X	X						
14	X	X	X	X	X						
16	X	X	X	X	X	X					
18	X	X	X	X	X	X					
20	X	X	X	X	X	X	X	X			
22	X	X	X	X	X	X					
25	X	X	X	X	X	X	X	X	X		
30	X	X	X	X	X	X	X	X	X	X	
35	X	X	X	X	X	X	X	X	X	X	
40	X	X	X	X	X	X	X	X	X	X	
45	X	X	X	X	X	X	X	X	X	X	
50		X	X	X	X	X	X	X	X	X	
55			X	X	X	X	X	X	X	X	
60			X	X	X	X	X	X	X	X	X
65				X	X	X	X	X	X	X	X
70				X	X	X	X	X	X	X	X
80				X	X	X	X	X	X	X	X
90				X	X	X	X	X	X	X	X
100				X	X	X	X	X	X	X	X
110					X	X	X	X	X	X	X
120					X	X	X	X	X	X	X
130					X	X	X	X	X	X	X
140					X	X	X	X	X	X	X
150					X	X	X	X	X	X	X
160					X	X	X	X	X	X	X
180									X	X	X
200									X	X	X
220										X	X
240										X	X
260										X	X

KRYSSMARKERADE ARTIKLAR MOT FÖRFRÅGAN !
 ÖVRIGA DIMENSIONER OCH LÄNGDER MOT FÖRFRÅGAN !

FÖRP.	M3	M4	M5	M6	M8	M10	M12	M14	M16	M20	M24
500 ST	6-	8-									
200 ST		16-	8-	8-							
100 ST				100-	10-	16-	20-				
50 ST						90-	70-	20-	20-		
25 ST									70-	30-	
10 ST										100-	100-

BESTÄLLNINGSEXEMPEL: 1203110050 - MF6S M10X50 10.9 OBEH

SWEBOLT AB
TEL 08 - 555 975 00 FAX 08 - 583 581 82

ARTIKELLISTA
2013-2014
FÖRSÄNKT INSEXSKRUV
MF6S 10.9 DIN 7991 FZB
BLANKFÖRZINKAD



GÄNGA	M3	M4	M5	M6	M8	M10	M12	M16	M20
Ytterd	6	8	10	12	16	20	24	30	36
Insex	2	2.5	3	4	5	6	8	10	12
Skalh	1.7	2.3	2.8	3.3	4.4	5.5	6.5	7.5	8.5
Gängl	12	14	16	18	22	26	30	38	46
Längd	C:A PRIS/100 ST								
5	X								
6	X	X							
8	X	X	X	X					
10	X	X	X	X	X				
12	X	X	X	X	X	X			
14	X	X	X	X	X				
16	X	X	X	X	X	X	X		
18		X		X		X			
20	X	X	X	X	X	X	X		
22				X	X				
25	X	X	X	X	X	X	X		
30		X	X	X	X	X	X	X	
35		X	X	X	X	X	X	X	
40		X	X	X	X	X	X	X	
45			X	X	X	X	X	X	X
50			X	X	X	X	X	X	
55				X	X				
60				X	X	X	X	X	
65					X				
70				X	X	X	X	X	
80					X	X	X	X	
90				X	X	X	X	X	
100				X	X	X	X	X	
110									
120						X			

ÖVRIGA DIMENSIONER OCH LÄNGDER MOT FÖRFRÅGAN !

FÖRP.	M3	M4	M5	M6	M8	M10	M12	M16	M20
500 ST	6-	6-	8-	8-					
200 ST			16-	12-	10-	16-			
100 ST				90-	80-	35-	16-	25-	
50 ST						100-	70-	30-	
25 ST								70-	30-

BESTÄLLNINGSEXEMPEL: 1203208040 - MF6S M8X40 10.9 FZB



ARTIKELLISTA
2013-2014
LÅG INSEXSKRUV
MLC6S 8.8 DIN 7984
OBEHANDLAD

GÄNGA	M3	M4	M5	M6	M8	M10	M12	M14	M16	M20	M24
Ytterd	5.5	7	8.5	10	13	16	18	21	24	30	36
Insex	2	2.5	3	4	5	7	8	10	12	14	17
Skallh	2.5	2.8	3.5	4	5	6	7	8	9	11	13
Gängl	12	14	16	18	22	26	30	34	38	46	54
Längd	C:A PRIS/100 ST										
6	X	X	X	X							
8	X	X	X	X							
10	X	X	X	X	X						
12	X	X	X	X	X	X					
14			X	X	X						
16	X	X	X	X	X	X					
20	X	X	X	X	X	X	X				
25	X	X	X	X	X	X	X		X		
30	X	X	X	X	X	X	X		X	X	
35		X	X	X	X	X	X		X	X	
40		X	X	X	X	X	X		X	X	X
45		X	X	X	X	X	X		X	X	X
50		X	X	X	X	X	X		X	X	X
55			X	X	X	X	X		X	X	X
60			X	X	X	X	X		X	X	X
65				X	X	X	X		X		
70				X	X	X	X		X	X	X
80					X	X	X		X	X	X
90					X	X	X		X	X	X
100					X	X	X		X	X	X
120											X

ÖVRIGA DIMENSIONER OCH LÄNGDER MOT FÖRFRÅGAN !

FÖRP.	M3	M4	M5	M6	M8	M10	M12	M14	M16	M20	M24
500 ST	6-	6-	10-	12-	8-						
200 ST				40-	12-	12-	20-				
100 ST					70-	30-	30-				
50 ST						100-	60-		25-		
25 ST										60-	

BESTÄLLNINGSEXEMPEL: 1206008020 = MLC6S M8X20 8.8 OBEH

SWEBOLT AB

TEL 08 - 555 975 00 FAX 08 - 583 581 82

ARTIKELLISTA
2013-2014
LÅG INSEXSKRUV
MLC6S 8.8 DIN 7984
BLANKFÖRZINKAD



GÄNGA	M3	M4	M5	M6	M8	M10	M12	M14	M16	M20	M24
Ytterd	5.5	7	8.5	10	13	16	18	21	24	30	36
Insex	2	2.5	3	4	5	7	8	10	12	14	17
Skallh	2.5	2.8	3.5	4	5	6	7	8	9	11	13
Gängl	12	14	16	18	22	26	30	34	38	46	54
Längd	C:A PRIS/100 ST										
6	X	X	X								
8	X	X	X	X	X						
10	X	X	X	X	X						
12	X	X	X	X	X						
14		X		X	X						
16	X	X	X	X	X	X					
20	X	X	X	X	X	X	X				
25	X	X	X	X	X	X	X		X		
30		X	X	X	X	X	X		X		
35			X	X	X	X	X		X	X	
40			X	X	X	X	X		X	X	
45				X	X	X	X		X	X	
50				X	X	X	X		X	X	
55					X	X			X		
60					X	X	X		X	X	
65					X						
70					X	X	X		X	X	
80					X	X	X		X	X	
100											
120											
140											

ÖVRIGA DIMENSIONER OCH LÄNGDER MOT FÖRFRÅGAN !

FÖRP.	M3	M4	M5	M6	M8	M10	M12	M14	M16	M20	M24
500 ST		6-	10-	12-	8-						
200 ST				40-	12-	12-	20-				
100 ST					70-		30-				
50 ST									25-		

BESTÄLLNINGSEXEMPEL: 1206108020 - MLC6S M8X20 8.8 FZB



ARTIKELLISTA
2013-2014
LÅG INSEXSKRUV
MLC6S 10.9 DIN 7984
OBEHANDLAD

GÄNGA	M3	M4	M5	M6	M8	M10	M12	M14	M16	M20	M24
Ytterd	5.5	7	8.5	10	13	16	18	21	24	30	36
Insex	2	2.5	3	4	5	7	8	10	12	14	17
Skallh	2.5	2.8	3.5	4	5	6	7	8	9	11	13
Gängl	12	14	16	18	22	26	30	34	38	46	54
Längd	C:A PRIS/100 ST										
6											
8											
10				X							
12			X	X							
14											
16			X	X	X						
20					X	X	X		X		
25					X	X	X		X		
30						X	X		X		
35					X				X		
40									X		
45									X		
50						X			X	X	
55											
60					X				X	X	
65											
70									X	X	
80											
90											
100									X		

ÖVRIGA DIMENSIONER OCH LÄNGDER MOT FÖRFRÅGAN !

FÖRP.	M3	M4	M5	M6	M8	M10	M12	M14	M16	M20	M24
500 ST	6-	6-	10-	12-	8-						
200 ST				40-	12-	12-	20-				
100 ST					70-	30-	30-				
50 ST						100-	60-		25-		
25 ST										60-	

BESTÄLLNINGSEXEMPEL: 1206208020 = MLC6S M8X20 10.9 OBEH

SWEBOLT AB

TEL 08 - 555 975 00 FAX 08 - 583 581 82



ARTIKELLISTA
2013-2014
KULLRIG INSEXSKRUV
K6S 10.9 ISO 7380
OBEHANDLAD

GÄNGA	M3	M4	M5	M6	M8	M10	M12
Ytterd	5.7	7.6	9.5	10.5	14	17.5	21
Insex	2	2,5	3	4	5	6	8
Skallh	1.65	2.2	2.75	3.3	4.4	5.5	6.6
Längd	C:A PRIS/100 ST						
4	X						
5	X	X					
6	X	X	X	X			
8	X	X	X	X			
10	X	X	X	X	X		
12	X	X	X	X	X	X	
14				X	X		
16	X	X	X	X	X	X	
20	X	X	X	X	X	X	
22			X				
25	X	X	X	X	X	X	
30	X	X	X	X	X	X	X
35		X	X	X	X	X	X
40		X	X	X	X	X	
45			X	X	X	X	
50				X	X	X	
55				X	X	X	
60				X	X	X	
70					X	X	
80					X		
90							
100							

ÖVRIGA DIMENSIONER OCH LÄNGDER MOT FÖRFRÅGAN !

FÖRP.	M3	M4	M5	M6	M8	M10	M12
500 ST	4-	6-	5-	8-			
200 ST		30-	35-	10-	10-	16-	
100 ST					25-	30-	30-

BESTÄLLNINGSEXEMPEL: 1207008020 - K6S M8x20 10.9 OBEH

SWEBOLT AB

TEL 08 - 555 975 00 FAX 08 - 583 581 82

ARTIKELLISTA
2013-2014
KULLRIG INSEXSKRUV
K6S 10.9 ISO 7380 FZB
BLANKFÖRZINKAD



GÄNGA	M3	M4	M5	M6	M8	M10	M12
Ytterd	5.7	7.6	9.5	10.5	14	17.5	21
Insex	2	2.5	3	4	5	6	8
Skallh	1.65	2.2	2.75	3.3	4.4	5.5	6.6
Längd	C:A PRIS/100 ST						
5	X						
6	X	X	X				
8	X	X	X	X			
10	X	X	X	X	X		
12	X	X	X	X	X		
14				X	X		
16	X	X	X	X	X	X	
18				X			
20	X	X	X	X	X	X	X
22				X	X		
25	X	X	X	X	X	X	X
30		X	X	X	X	X	X
35			X	X	X	X	
40			X	X	X	X	X
45				X	X	X	
50			X	X	X	X	
55							
60				X	X	X	
70					X	X	
80					X		
90							
100					X		
110							

ÖVRIGA DIMENSIONER OCH LÄNGDER MOT FÖRFRÅGAN !

FÖRP.	M3	M4	M5	M6	M8	M10	M12
500 ST	5-	6-	8-	8-			
200 ST			40-	16-	10-		
100 ST					50-	25-	25-

BESTÄLLNINGSEXEMPEL: 1207106025 - K6S M6X25 10.9 FZB

ARTIKELLISTA
2013-2014
KULLRIG INSEXSKRUV
K6S 10.9 ISO 7380 FZB
BLANKFÖRZINKAD

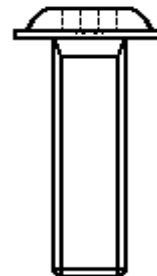

GÄNGA	M3	M4	M5	M6	M8	M10	M12
Ytterd	6.6	8.7	10.8	12.9	16.2	19.9	23.6
Insex	2	2.5	3	4	5	6	8
Skallh	1.65	2.2	2.75	3.3	4.4	5.5	6.6
Längd	C:A PRIS/100 ST						
5							
6							
8							
10				X			
12				X	X		
14							
16				X			
18							
20				X			
22							
25				X			
30				X			
35				X			
40				X			
45				X			
50							
55							
60							
70							
80							
90							
100							
110							

ÖVRIGA DIMENSIONER OCH LÄNGDER MOT FÖRFRÅGAN !

FÖRP.	M3	M4	M5	M6	M8	M10	M12
500 ST	5-	6-	8-	8-			
200 ST					10-		
100 ST					50-	25-	25-

BESTÄLLNINGSEXEMPEL: 1207306012 - K6SF M6x12 10.9 FZB

ARTIKELLISTA

2013-2014

STOPPSKRUV

P6SS 45HRC DIN 913 / ISO 4026 PLAN



DIM	M3	M4	M5	M6	M8	M10	M12	M16	M20	M24
INSEX	1.5	2	2.5	3	4	5	6	8	10	12
Längd	C:A PRIS/100 ST									
3	X									
4	X	X	X	X						
5	X	X	X	X						
6	X	X	X	X	X					
8	X	X	X	X	X	X				
10	X	X	X	X	X	X	X			
12	X	X	X	X	X	X	X			
14		X	X	X	X					
16	X	X	X	X	X	X	X	X		
20	X	X	X	X	X	X	X	X	X	
22		X	X							
25		X	X	X	X	X	X	X	X	X
30		X	X	X	X	X	X	X	X	X
35		X	X	X	X	X	X	X	X	X
40		X	X	X	X	X	X	X	X	X
45				X	X	X	X	X	X	
50				X	X	X	X	X	X	X
55					X	X	X			
60					X	X	X	X	X	X
65							X			
70					X	X	X	X	X	X
80					X	X	X	X	X	X
90								X	X	X
100										X

BESTÄLLNINGSEXEMPEL: 1208004020 - P6SS M4X20 45H

S6SS 45HRC DIN 914 / ISO 4027 SPETSIG

DIM	M3	M4	M5	M6	M8	M10	M12	M16	M20	M24
Längd	C:A PRIS/100 ST									
3	X									
4	X	X	X							
5	X	X	X	X						
6	X	X	X	X	X					
8	X	X	X	X	X	X				
10	X	X	X	X	X	X	X			
12	X	X	X	X	X	X	X			
14			X	X			X			
16	X	X	X	X	X	X	X	X		
20	X	X	X	X	X	X	X	X	X	
22										
25		X	X	X	X	X	X	X	X	
30		X	X	X	X	X	X	X	X	
35		X	X	X	X	X	X	X	X	X
40		X	X	X	X	X	X	X	X	X
45				X	X	X	X	X	X	X
50				X	X	X	X	X	X	X
55					X	X	X	X		
60					X	X	X	X	X	X

BESTÄLLNINGSEXEMPEL: 1209008030 - S6SS M8X30 45H

FÖRP.	M3	M4	M5	M6	M8	M10	M12	M16	M20	M24
200 ST	4-	4-	5-	6-	8-	10-	10-			
100 ST				35-	35-	35-	14-	16-		
50 ST							70-	25-	20-	
25 ST									60-	25-

SWEBOLT AB

TEL 08 - 555 975 00 FAX 08 - 583 581 82



ARTIKELLISTA

2013-2014

STOPPSKRUV MED TAPP T6SS 45HRC DIN 915 / ISO 4028 TAPP



DIM	M3	M4	M5	M6	M8	M10	M12	M16	M20	M24
INSEX	1.5	2	2.5	3	4	5	6	8	10	12
Längd	C:A PRIS/100 ST									
5	X	X	X	X						
6	X	X	X	X	X					
8	X	X	X	X	X	X				
10	X	X	X	X	X	X	X			
12	X	X	X	X	X	X	X			
14					X					
16	X	X	X	X	X	X	X	X		
20	X	X	X	X	X	X	X	X	X	
22						X				
25		X	X	X	X	X	X	X	X	
30		X	X	X	X	X	X	X	X	X
35		X	X	X	X	X	X	X	X	X
40		X	X	X	X	X	X	X	X	X
45				X	X	X	X	X	X	X
50				X	X	X	X	X	X	X
55					X	X	X	X	X	X
60					X	X	X	X	X	X
70					X	X	X	X	X	X
80					X	X	X	X	X	X

BESTÄLLNINGSEXEMPEL: 1210006030 - T6SS M6X30 45H

SK6SS 45HRC DIN 916 / ISO 4029 SKÅLAD

DIM	M3	M4	M5	M6	M8	M10	M12	M16	M20	M24
Längd	C:A PRIS/100 ST									
3	X									
4	X	X	X							
5	X	X	X	X						
6	X	X	X	X	X	X				
8	X	X	X	X	X	X				
10	X	X	X	X	X	X	X			
12	X	X	X	X	X	X	X			
14	X	X	X	X	X	X	X			
16	X	X	X	X	X	X	X	X		
20	X	X	X	X	X	X	X	X	X	
22				X						
25		X	X	X	X	X	X	X	X	
30		X	X	X	X	X	X	X	X	X
35		X	X	X	X	X	X	X	X	X
40		X	X	X	X	X	X	X	X	X
45				X	X	X	X	X	X	X
50			X	X	X	X	X	X	X	X
55					X	X	X	X		
60					X	X	X	X	X	X
65										
70					X	X	X	X	X	X
75										
80					X	X	X	X	X	X
90								X	X	X

BESTÄLLNINGSEXEMPEL: 1211010050 - SK6SS M10X50 45H

ÖVRIGA DIMENSIONER OCH LÄNGDER MOT FÖRFRÅGAN !

FÖRP.	M3	M4	M5	M6	M8	M10	M12	M16	M20	M24
200 ST	4-	4-	5-	5-	8-	6-	10-			
100 ST					50-	35-	20-	16-		
50 ST							70-	30-	30-	
25 ST									50-	30-

SWEBOLT AB

TEL 08 - 555 975 00 FAX 08 - 583 581 82



ARTIKELLISTA
2013-2014
PASSBULT
MC6SPB 12.9 ISO 7379
OBEHANDLAD

PASSNING	ø 6	ø 8	ø 10	ø 12	ø 16	ø 20	ø 24
GÄNGA	M5	M6	M8	M10	M12	M16	M20
Skalld	10	13	16	18	24	30	36
Skallh	4.5	5.5	7	8	10	14	16
GL	9.5	11	13	16	18	22	27
Nyckel	3	4	5	6	8	10	12
Längd	C:A PRIS/100 ST						
8	X						
10	X	X					
12	X	X	X	X			
16	X	X	X	X			
20	X	X	X	X			
25	X	X	X	X	X		
30	X	X	X	X	X		
35	X	X	X	X	X	X	
40	X	X	X	X	X	X	
45	X	X	X	X	X	X	
50	X	X	X	X	X	X	X
55		X	X	X	X	X	
60		X	X	X	X	X	X
65							
70			X	X	X	X	X
75							
80			X	X	X	X	X
90				X	X	X	X
100				X	X	X	X
110							
120					X	X	X

ÖVRIGA DIMENSIONER OCH LÄNGDER MOT FÖRFRÅGAN !

FÖRP	M5	M6	M8	M10	M12	M16	M20
1 ST	8-	10-	12-	12-	25-	35-	50-

BESTÄLLNINGSEXEMPEL: 1216010016 - MC6SPB M10H12x16 12.9

SWEBOLT AB

TEL 08 - 555 975 00 FAX 08 - 583 581 82

ARTIKELLISTA
2013-2014
FÖRSÄNKT STARSKRUV
MFTS 8.8 DIN 7991 FZB
BLANKFÖRZINKAD



GÄNGA	M3	M4	M5	M6	M8	M10	M12	M16	M20
Ytterd	6	8	10	12	16	20	24	30	36
STAR	T10	T20	T25	T30	T40				
Skallh	1.7	2.3	2.8	3.3	4.4	5.5	6.5	7.5	8.5
Gängl	12	14	16	18	22	26	30	38	46
Längd	C:A PRIS/100 ST								
5									
6									
8									
10		X	X	X					
12		X	X	X					
14									
16		X	X	X	X				
18									
20		X	X	X	X				
22									
25			X	X	X				
30					X				
35									
40				X					
45									
50									
55									
60									
65									
70									
80									
90									
100									
110									
120									

ÖVRIGA DIMENSIONER OCH LÄNGDER MOT FÖRFRÅGAN !

FÖRP.	M3	M4	M5	M6	M8	M10	M12	M16	M20
500 ST	6-	6-	8-	8-					
200 ST			16-	12-	10-	16-			
100 ST				90-	80-	35-	16-	25-	
50 ST						100-	70-	30-	
25 ST								70-	30-

BESTÄLLNINGSEXEMPEL: 1221604016 - MFTS M4x16 8.8 FZB

ARTIKELLISTA

2013-2014

INSEXSRUV ANSI B18.2.1 Serie 1960

UNC-GÄNGA 12.9



GÄNGA	NR 1	NR 2	NR 3	NR 4	NR 5	NR 6	NR 8	NR 10	1/4	5/16	3/8	7/16
Gängstign.	64	56	48	40	40	32	32	24	20	18	16	14
Nyckel	1/16	5/64	5/64	3/32	3/32	7/64	9/64	5/32	3/16	1/4	5/16	3/8
Skalld	0,118	0,14	0,161	0,183	0,205	0,226	0,27	5/16	3/8	15/32	9/16	21/32
Skallh	0,073	0,086	0,099	0,112	0,125	0,138	0,164	0,19	1/4	5/16	3/8	7/16
Längd	C:A PRIS / 100 ST											
3/16 4,8												
1/4 6,4												
5/16 7,9												
3/8 9,5												
1/2 13									X			
5/8 16									X	X	X	
3/4 19									X	X	X	X
7/8 22									X	X	X	
1" 25								X	X	X	X	X
1 1/4 32									X	X	X	X
1 1/2 38									X	X	X	X
1 3/4 45									X	X	X	X
2" 51									X	X	X	X
2 1/4 57									X	X	X	X
2 1/2 64									X	X	X	X
2 3/4 70									X	X		
3" 76										X	X	X
3 1/4 83										X	X	
3 1/2 89										X	X	X
3 3/4 95												
4" 102											X	
4 1/2 114												
5" 127											X	
5 1/2 140												
6" 152												
6 1/2 165												
7" 178												
7 1/2 191												
8" 203												
9" 229												
10" 254												
11" 279												
12" 305												

ÖVRIGA DIMENSIONER OCH LÄNGDER MOT FÖRFRÅGAN !

FÖRP.	NR 1	NR 2	NR 3	NR 4	NR 5	NR 6	NR 8	NR 10	1/4	5/16	3/8	7/16
200 ST								25-	13-			
100 ST									70-	16-	16-	
50 ST											83-	16-

BESTÄLLNINGSEXEMPEL: 12017065019 - UC6S 1/4UNCx19 12,9

UNF-GÄNGA MOT FÖRFRÅGAN

SWEBOLT AB

TEL 08 - 555 975 00 FAX 08 - 583 581 82



ARTIKELLISTA

2013-2014

INSEXSKRUV ANSI B18.2.1 Serie 1960

UNC-GÄNGA 12.9

GÄNGA	1/2	5/8	3/4	7/8	1"	1 1/8	1 1/4	1 3/8	1 1/2	1 3/4	2"
Gängstign.	13	11	10	9	8	7	7	6	6	5	4,5
Nyckel	3/8	1/2	5/8	3/4	3/4	7/8	7/8	1"	1"	1 1/4	1 1/2
Skalld	3/4	15/16	1 1/8	1,5/16	1,1/2	1,688	1,875	2,062	2,250	2,625	3
Skallh	1/2	5/8	3/4	7/8	1	1,125	1,25	1,375	1,5	1,75	2
Längd	C:A PRIS / 100 ST										
1/2 13											
5/8 16											
3/4 19											
7/8 22											
1" 25	X	X									
1 1/4 32	X	X	X								
1 1/2 38	X	X	X		X						
1 3/4 45	X	X	X								
2" 51	X	X	X	X	X						
2 1/4 57	X			X							
2 1/2 64	X	X	X	X	X						
2 3/4 70		X			X						
3" 76	X	X	X	X							
3 1/4 83	X	X									
3 1/2 89	X		X	X	X						
3 3/4 95											
4" 102	X	X	X		X						
4 1/2 114		X	X	X							
5" 127	X	X	X		X						
5 1/2 140		X	X								
6" 152			X	X							
6 1/2 165											
7" 178			X								
7 1/2 191											
8" 203											
9" 229			X								
10" 254											
11" 279											
12" 305											

ÖVRIGA DIMENSIONER OCH LÄNGDER MOT FÖRFRÅGAN !

FÖRP.	1/2	5/8	3/4	7/8	1"	1 1/8	1 1/4	1 3/8	1 1/2	1 3/4	2"
50 ST	25-	25-									
25 ST	114-	64-	38-								
10 ST		114-	64-	51-	38-						
1 ST			229-								

BESTÄLLNINGSEXEMPEL: 12017161114 - UC6S 5/8UNCx114 12,9

UNF-GÄNGA MOT FÖRFRÅGAN

SWEBOLT AB

TEL 08 - 555 975 00 FAX 08 - 583 581 82

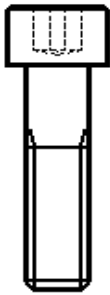

ARTIKELLISTA
2013-2014
INSEXSKRUV
MC6S ISO 4762 / DIN 912
ROSTFRI A2

GÄNGA	M1.6	M2	M2.5	M3	M4	M5	M6	M8	M10	M12	M14	M16	M20	M24
Ytterd	3	3.8	4.5	5.5	7	8.5	10	13	16	18	21	24	30	39
Insex	1.5	1.5	2	2.5	3	4	5	6	8	10	12	14	17	19
Skallh	1.6	2	2.5	3	4	5	6	8	10	12	14	16	20	24
Gängl	15	16	17	18	20	22	24	28	32	36	40	44	52	60
Längd	C:A PRIS/100 ST													
3	X	X												
4	X	X	X	X										
5	X	X	X	X	X									
6	X	X	X	X	X	X	X							
8	X	X	X	X	X	X	X							
10	X	X	X	X	X	X	X	X						
12	X	X	X	X	X	X	X	X	X					
14		X	X	X	X	X	X	X						
16	X	X	X	X	X	X	X	X	X	X				
18				X	X	X	X	X	X					
20		X	X	X	X	X	X	X	X	X	X			
25			X	X	X	X	X	X	X	X	X	X		
30				X	X	X	X	X	X	X	X	X	X	
35				X	X	X	X	X	X	X	X	X	X	
40				X	X	X	X	X	X	X	X	X	X	X
45				X	X	X	X	X	X	X	X	X	X	X
50				X	X	X	X	X	X	X	X	X	X	X
55					X	X	X	X	X	X	X	X	X	X
60					X	X	X	X	X	X	X	X	X	X
65						X	X	X	X	X	X	X	X	X
70					X	X	X	X	X	X	X	X	X	X
75					X		X	X	X	X	X	X	X	X
80						X	X	X	X	X	X	X	X	X
90						X	X	X	X	X	X	X	X	X
100						X	X	X	X	X	X	X	X	X
110							X	X	X	X	X	X	X	X
120							X	X	X	X	X	X	X	X
130							X	X	X	X	X	X	X	X
140							X	X	X	X	X	X	X	X
150							X	X	X	X	X	X	X	X
200								X	X	X		X	X	

KRYSSMARKERADE ARTIKLAR MOT FÖRFRÅGAN !
 ÖVRIGA DIMENSIONER OCH LÄNGDER MOT FÖRFRÅGAN !

FÖRP.	M1.6	M2	M2.5	M3	M4	M5	M6	M8	M10	M12	M14	M16	M20	M24
500 ST	3-	3-	4-	8-	8-	6-	6-							
200 ST					30-	30-	16-	10-						
100 ST						45-	50-	16-	12-	20-				
50 ST								110-	75-	45-	20-	25-		
25 ST									200-	100-	100-	65-	30-	40-

BESTÄLLNINGSEXEMPEL: 2200006020 - MC6S M6x20 A2

SWEBOLT AB

TEL 08 - 555 975 00 FAX 08 - 583 581 82

ARTIKELLISTA
2013-2014
INSEXSKRUV
MC6S ISO 4762 / DIN 912
SYRAFAST A4-80, A4-70

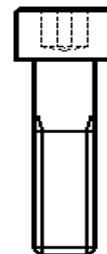

GÄNGA	M1.4	M1.6	M2	M2.5	M3	M4	M5	M6	M8	M10	M12	M14	M16	M20	M24
Ytterd	2.6	3	3.8	4,5	5.5	7	8.5	10	13	16	18	21	24	30	36
Insex	1.3	1.5	1.5	2	2.5	3	4	5	6	8	10	12	14	17	19
Skallh	1.4	1.6	2	2,5	3	4	5	6	8	10	12	14	16	20	24
Gängl	14	15	16	17	18	20	22	24	28	32	36	40	44	52	60
Längd	C:A PRIS/100 ST														
3	X	X	X												
4	X	X	X	X	X										
5	X	X	X	X	X	X									
6	X	X	X	X	X	X	X								
8		X	X	X	X	X	X	X							
10		X	X	X	X	X	X	X	X						
12		X	X	X	X	X	X	X	X	X					
14			X	X	X	X	X	X	X						
16			X	X	X	X	X	X	X	X					
18			X	X	X	X	X	X	X	X	X				
20			X	X	X	X	X	X	X	X	X	X			
22					X	X	X	X	X	X	X				
25				X	X	X	X	X	X	X	X	X	X		
30					X	X	X	X	X	X	X	X	X		
35					X	X	X	X	X	X	X	X	X	X	
40					X	X	X	X	X	X	X	X	X	X	X
45					X	X	X	X	X	X	X	X	X	X	X
50					X	X	X	X	X	X	X	X	X	X	X
55							X	X	X	X	X	X	X	X	X
60						X	X	X	X	X	X	X	X	X	X
65							X	X	X	X	X		X	X	X
70						X	X	X	X	X	X	X	X	X	X
75						X	X	X	X	X	X		X	X	X
80							X	X	X	X	X	X	X	X	X
90							X	X	X	X	X	X	X	X	X
100							X	X	X	X	X	X	X	X	X
110								X	X	X	X	X	X	X	X
120								X	X	X	X	X	X	X	X
130								X	X	X	X	X	X	X	X
140								X	X	X	X	X	X	X	X
150								X	X	X	X	X	X	X	X
160									X	X	X	X	X	X	X

KRYSSMARKERADE ARTIKLAR MOT FÖRFRÅGAN!
 ÖVRIGA DIMENSIONER OCH LÄNGDER MOT FÖRFRÅGAN!

FÖRP.	M1.4	M1.6	M2	M2.5	M3	M4	M5	M6	M8	M10	M12	M14	M16	M20	M24
500 ST					4-	5-	6-	8-							
200 ST	3-	3-	3-	4-	8-	14-	25-	12-	10-						
100 ST							60-	35-	30-	16-	20-				
50 ST									120-	75-	50-	25-	25-		
25 ST									200-	110-	110-	80-	30-	35-	40-

BESTÄLLNINGSEXEMPEL: 2200508025 - MC6S M8x25 A4-80

SWEBOLT AB
TEL 08 - 555 975 00 FAX 08 - 583 581 82

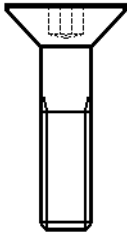

ARTIKELLISTA
2013-2014
FÖRSÄNKT INSEXSKRUV
MF6S DIN 7991
ROSTFRI A2

GÄNGA	M3	M4	M5	M6	M8	M10	M12	M16	M20	M24
Ytterd	6	8	10	12	16	20	24	30	36	39
Insex	2	2.5	3	4	5	6	8	10	12	14
Skallh	1.7	2.3	2.8	3.3	4.4	5.5	6.5	7.5	8,5	14
Gängl	12	14	16	18	22	26	30	38	46	54
Längd	C:A PRIS/100 ST									
6	X	X	X							
8	X	X	X	X						
10	X	X	X	X	X					
12	X	X	X	X	X					
14	X	X	X	X	X					
16	X	X	X	X	X	X				
18	X	X	X	X	X	X				
20	X	X	X	X	X	X	X			
22			x	x	X					
25	X	X	X	X	X	X	X	X		
30	X	X	X	X	X	X	X	X		
35	X	X	X	X	X	X	X	X	X	
40	X	X	X	X	X	X	X	X	X	
45		X	X	X	X	X	X	X	X	
50		X	X	X	X	X	X	X	X	X
60		X	X	X	X	X	X	X	X	X
70			X	X	X	X	X	X	X	X
80			X	X	X	X	X	X	X	X
90			X	X	X	X	X	X	X	X
100			X	X	X	X	X	X	X	X
110					X	X		X	X	X
120					X	X		X	X	X
130					X	X		X	X	X
140					X	X		X	X	X
150					X			X	X	X

KRYSSMARKERADE ARTIKLAR MOT FÖRFRÅGAN !
 ÖVRIGA DIMENSIONER OCH LÄNGDER MOT FÖRFRÅGAN !

FÖRP.	M3	M4	M5	M6	M8	M10	M12	M16	M20	M24
500 ST	6-	6-	6-	8-						
200 ST		30-	30-	14-	10-					
100 ST					30-	16-	20-			
50 ST						60-	45-	25-		
25 ST								65-	35-	50-

BESTÄLLNINGSEXEMPEL: 2203006030 - MF6S M6X30 A2

SWEBOLT AB

TEL 08 - 555 975 00 FAX 08 - 583 581 82

ARTIKELLISTA
2013-2014
FÖRSÄNKT INSEXSKRUV
MF6S DIN 7991
SYRAFAST A4

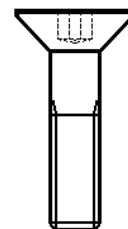

GÄNGA	M2	M2.5	M3	M4	M5	M6	M8	M10	M12	M16	M20	M24
Ytterd	4	5	6	8	10	12	16	20	24	30	36	39
Insex	1.3	1.5	2	2.5	3	4	5	6	8	10	12	14
Skallh	1.2	1.5	1.7	2.3	2.8	3.3	4.4	5.5	6.5	7.5	8.5	14
Gängl			12	14	16	18	22	26	30	38	46	54
Längd	C:A PRIS/100 ST											
3	X											
4	X	X										
5	X	X										
6	X	X	X	X								
8	X	X	X	X	X	X						
10	X	X	X	X	X	X	X					
12	X	X	X	X	X	X	X					
14			X	X	X	X	X					
16	X	X	X	X	X	X	X	X				
18				X	X	X	X	X				
20		X	X	X	X	X	X	X	X			
22				X	X	X	X	X	X			
25			X	X	X	X	X	X	X	X		
30			X	X	X	X	X	X	X	X		
35			X	X	X	X	X	X	X	X		
40			X	X	X	X	X	X	X	X	X	
45				X	X	X	X	X	X	X	X	
50				X	X	X	X	X	X	X	X	X
55						X	X	X	X	X	X	X
60				X	X	X	X	X	X	X	X	X
70				X	X	X	X	X	X	X	X	X
80						X	X	X	X	X	X	X
90							X	X	X	X	X	X
100							X	X	X	X	X	X
110								X	X	X	X	X
120							X	X	X	X	X	X
130										X	X	X
140									X	X	X	X
150										X	X	X

KRYSSMARKERADE ARTIKLAR MOT FÖRFRÅGAN !
 ÖVRIGA DIMENSIONER OCH LÄNGDER MOT FÖRFRÅGAN !

FÖRP.	M2	M2.5	M3	M4	M5	M6	M8	M10	M12	M16	M20	M24
500 ST	3-	4-	6-	6-	8-	8-						
200 ST				30-	30-	16-	10-					
100 ST						45-	25-	16-				
50 ST							70-	50-	20-			
25 ST									80-	25-	40-	50-

BESTÄLLNINGSEXEMPEL: 2203108025 - MF6S M8x25 A4

ARTIKELLISTA

2013-2014

LÅG INSEXSKRUV MLC6S DIN 7984

ROSTFRI A2

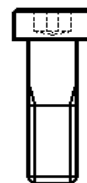

GÅNGA	M3	M4	M5	M6	M8	M10	M12	M16	M20	M24
Ytterd	5.5	7	8.5	10	13	16	18	24	30	36
Insex	2	2.5	3	4	5	7	8	12	14	17
Skallh	2	2.8	3.5	4	5	6	7	9	11	13
Gängl	12	14	16	18	22	26	30	38	46	54
Längd	C:A PRIS/100 ST									
5	X									
6	X	X	X							
8	X	X	X	X						
10	X	X	X	X	X					
12	X	X	X	X	X					
16	X	X	X	X	X	X				
20	X	X	X	X	X	X	X			
25	X	X	X	X	X	X	X	X		
30	X	X	X	X	X	X	X	X		
35	X	X	X	X	X	X	X	X	X	
40	X	X	X	X	X	X	X	X	X	
45			X	X	X	X	X	X	X	
50			X	X	X	X	X	X	X	
55			X	X	X	X	X	X	X	
60			X	X	X	X	X	X	X	
70						X	X	X	X	
80						X	X	X	X	

SYRAFAST A4

GÅNGA	M3	M4	M5	M6	M8	M10	M12	M16	M20	M24
6	X	X								
8	X	X	X	X						
10	X	X	X	X	X					
12	X	X	X	X	X					
16	X	X	X	X	X	X	X			
20	X	X	X	X	X	X	X			
25		X	X	X	X	X	X	X		
30		X	X	X	X	X	X	X		
35		X	X	X	X	X	X	X	X	
40		X	X	X	X	X	X	X	X	
45				X	X	X	X	X	X	
50				X	X	X	X	X	X	
55				X	X	X	X	X	X	
60				X	X	X	X	X	X	
70					X	X	X	X	X	
80					X	X	X	X	X	

KRYSSMARKERADE ARTIKLAR MOT FÖRFRÅGAN !

FÖRP.	M3	M4	M5	M6	M8	M10	M12	M16	M20	M24
1000 ST	6-									
500 ST		6-	8-							
200 ST				8-	10-					
100 ST				50-	45-	16-				
50 ST						50-	16-			
25 ST								25-	35-	

BESTÄLLNINGSEXEMPEL: 2206006012 - MLC6S M6x12 A2

BESTÄLLNINGSEXEMPEL: 2206106020 - MLC6S M6x20 A4

SWEBOLT AB

TEL 08 - 555 975 00 FAX 08 - 583 581 82

2:70

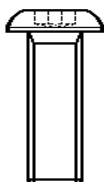

ARTIKELLISTA

2013-2014

KULLRIG INSEXSKRUV

K6S ISO 7380 ROSTFRI A2

GÄNGA	M3	M4	M5	M6	M8	M10	M12
Ytterd	5.7	7.6	9.5	10.5	14	17.5	21
Insex	2	2.5	3	4	5	6	8
Skallh	1.65	2.2	2.75	3.3	4.4	5.5	8
Gängl	18	20	22	24	28	36	36
Längd	C:A PRIS/100 ST						
4	X	X					
5	X	X					
6	X	X	X				
8	X	X	X	X			
10	X	X	X	X	X		
12	X	X	X	X	X	X	
14		X	X	X	X		
16	X	X	X	X	X	X	
20	X	X	X	X	X	X	X
25	X	X	X	X	X	X	X
30	X	X	X	X	X	X	X
35	X	X	X	X	X	X	X
40	X	X	X	X	X	X	X
45		X	X	X	X	X	X
50		X	X	X	X	X	X
55			X	X	X	X	X
60			X	X	X	X	X
70				X	X	X	
80					X	X	

K6S ISO 7380 SYRAFAST A4

GÄNGA	M3	M4	M5	M6	M8	M10	M12
Ytterd	5.7	7.6	9.5	10.5	14	17.5	21
Insex	2	2.5	3	4	5	6	8
Skallh	1.65	2.2	2.75	3.3	4.4	5.5	8
Gängl	18	20	22	24	28	36	36
Längd	C:A PRIS/100 ST						
5	X	X					
6	X	X	X				
8	X	X	X	X			
10	X	X	X	X	X		
12	X	X	X	X	X		
16	X	X	X	X	X	X	
20	X	X	X	X	X	X	X
25	X	X	X	X	X	X	X
30	X	X	X	X	X	X	X
35	X	X	X	X	X	X	X
40	X	X	X	X	X	X	X
45		X	X	X	X	X	X
50		X	X	X	X	X	X

KRYSSMARKERADE ARTIKLAR MOT FÖRFRÅGAN !
 ÖVRIGA DIMENSIONER OCH LÄNGDER MOT FÖRFRÅGAN !

FÖRP.	M3	M4	M5	M6	M8	M10	M12
500 ST	4-	4-	6-	8-			
200 ST			30-	16-	10-		
100 ST				40-	25-	16-	
50 ST						50-	20-

BESTÄLLNINGSEXEMPEL: 2207004016 - K6S M4x16 A2

BESTÄLLNINGSEXEMPEL: 2207106020 - K6S M6x20 A4

SWEBOLT AB

TEL 08 - 555 975 00 FAX 08 - 583 581 82

ARTIKELLISTA

2013-2014

**STOPPSKRUV P6SS/S6SS
ROSTFRI A2 - SYRAFAST A4**



P6SS ISO 4026 / DIN 913 A2 PLAN

DIM	M3	M4	M5	M6	M8	M10	M12	M16
INSEX	1.5	2	2.5	3	4	5	6	8
Längd	C:A PRIS/100 ST							
4	X	X	X	X				
5	X	X	X	X				
6	X	X	X	X	X			
8	X	X	X	X	X			
10	X	X	X	X	X	X		
12	X	X	X	X	X	X	X	
16	X	X	X	X	X	X	X	X
20	X	X	X	X	X	X	X	X
25	X	X	X	X	X	X	X	X
30	X	X	X	X	X	X	X	X
40		X	X	X	X	X	X	X
50	BESTÄLLNINGSEXEMPEL: 2208005008 - P6SS M5X8 A2					X	X	X

P6SS A4 ISO 4026 / DIN 913 PLAN

Längd	M3	M4	M5	M6	M8	M10	M12	M16
5	X	X	X					
6	X	X	X	X				
8	X	X	X	X	X			
10	X	X	X	X	X	X		
12	X	X	X	X	X	X		
16		X	X	X	X	X	X	X
20		X	X	X	X	X	X	X
25		X	X	X	X	X	X	X
30		X	X	X	X	X	X	X
35			X	X	X	X	X	X
40	BESTÄLLNINGSEXEMPEL:			X	X	X	X	X
50	2208105010 - P6SS M5X10 A4			X	X	X	X	X

S6SS A2 ISO 4027 / DIN 914 SPETS

Längd	M3	M4	M5	M6	M8	M10	M12	M16
4	X	X						
5	X	X	X	X				
6	X	X	X	X	X			
8	X	X	X	X	X			
10	X	X	X	X	X	X		
12	X	X	X	X	X	X	X	
16	X	X	X	X	X	X	X	
20	X	X	X	X	X	X	X	X
25	X	X	X	X	X	X	X	X
30		X	X	X	X	X	X	X
40	BESTÄLLNINGSEXEMPEL:			X	X	X	X	X
50	2209006010 - S6SS M6X10 A2			X	X	X	X	X

S6SS A4 ISO 4027 / DIN 914 SPETS

Längd	M3	M4	M5	M6	M8	M10	M12	M16
8	X	X	X	X	X			
10	X	X	X	X	X	X		
12	X	X	X	X	X	X	X	
16	X	X	X	X	X	X	X	X
20				X	X	X	X	X
25	BESTÄLLNINGSEXEMPEL:			X	X	X	X	X
40	2209106010 - S6SS M6X10 A4			x	x	X	x	x

ÖVRIGA DIMENSIONER OCH LÄNGDER MOT FÖRFRÅGAN !

FÖRP.	M3	M4	M5	M6	M8	M10	M12	M16
200 ST	4-	4-	5-	5-	6-			
100 ST				30-	25-	10-	12-	16-

SWEBOLT AB

TEL 08 - 555 975 00 FAX 08 - 583 581 82



ARTIKELLISTA

2013-2014

STOPPSKRUV T6SS/SK6SS

ROSTFRI A2 - SYRAFAST A4



T6SS A2 ISO 4028 / DIN 915 TAPP

DIM	M3	M4	M5	M6	M8	M10	M12	M16	M20
INSEX	1.5	2	2.5	3	4	5	6	8	10
Längd	C:A PRIS/100 ST								
6	X	X	X	X					
8	X	X	X	X	X				
10	X	X	X	X	X	X			
12	X	X	X	X	X	X	X		
16	X	X	X	X	X	X	X		
20	BESTÄLLNINGSEXEMPEL: 2210010020 - T6SS M10X20 A2			X	X	X	X	X	
25				X	X	X	X	X	

T6SS A4 ISO 4028 / DIN 915 TAPP

Längd	M3	M4	M5	M6	M8	M10	M12	M16	M20
6	X	X	X	X					
8	X	X	X	X	X				
10	X	X	X	X	X	X			
12	X	X	X	X	X	X			
16	X	X	X	X	X	X			
20	X	X	X	X	X	X	X		
25		X	X	X	X	X	X	X	
30		X	X	X	X	X	X		
35	BESTÄLLNINGSEXEMPEL: 2210110020 - T6SS M10X20 A4			X	X	X	X		
50				X	X	X	X		

SK6SS A2 ISO 4029 / DIN 916 SKÅLAD

Längd	M3	M4	M5	M6	M8	M10	M12	M16	M20
3	X								
4	X	X	X						
5	X	X	X	X					
6	X	X	X	X	X				
8	X	X	X	X	X				
10	X	X	X	X	X	X			
12	X	X	X	X	X	X	X		
16	X	X	X	X	X	X	X	X	
20	X	X	X	X	X	X	X	X	
25		X	X	X	X	X	X	X	
60	BESTÄLLNINGSEXEMPEL: 2211010020 - SK6SS M10x20 A2					X	X	X	

SK6SS A4 ISO 4029 / DIN 916 SKÅLAD







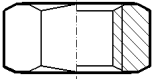
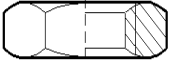
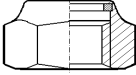
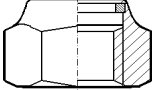
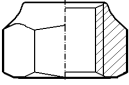
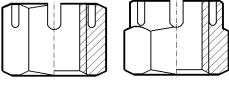
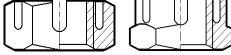

Längd	M3	M4	M5	M6	M8	M10	M12	M16	M20
4	X	X							
5	X	X	X						
6	X	X	X	X					
8	X	X	X	X	X				
10	X	X	X	X	X	X			
12	X	X	X	X	X	X	X		
16	X	X	X	X	X	X	X		
20	X	X	X	X	X	X	X	X	
25	X	X	X	X	X	X	X	X	
30	X	X	X	X	X	X	X	X	
35				X	X	X	X		
40				X	X	X	X		
50				X	X	X	X		
60	BESTÄLLNINGSEXEMPEL: 2211110020 - SK6SS M10x20 A4					X	X		

ÖVRIGA DIMENSIONER OCH LÄNGDER MOT FÖRFRÅGAN !

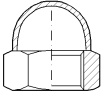
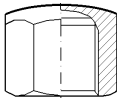
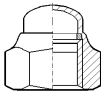
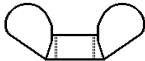
FÖRP.	M3	M4	M5	M6	M8	M10	M12	M16	M20
200 ST	4-	4-	6-	6-	8-				
100 ST			25-	25-	20-	10-	16-	16-	

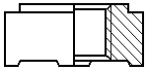
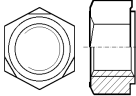
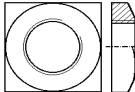
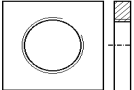

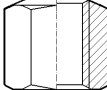

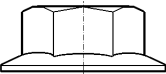
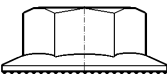
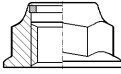
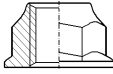
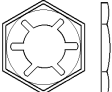
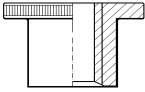
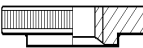
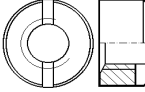
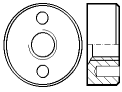
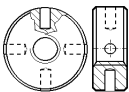
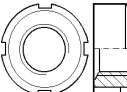
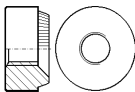





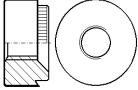
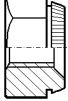
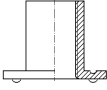
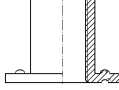
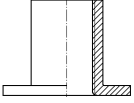
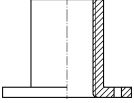
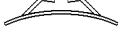
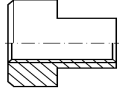
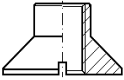

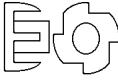
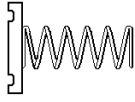
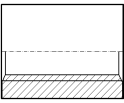
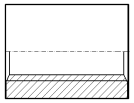
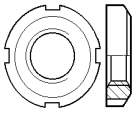
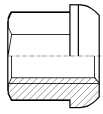
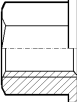
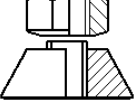



SWEBOLT AB

TEL 08 - 555 975 00 FAX 08 - 583 581 82

- 1 - 	- 2 - 	- 3 - 	- 4 - 
- 5 - 	- 6 - 	- 7 - 	- 8 - 
- 9 - 	- 10 - 	- 11 - 	- 12 - 
- 13 - 	- 14 - 	- 15 - 	- 16 - 
- 17 - 	- 18 - 	- 19 - 	- 20 - 
- 21 - 	- 22 - 	- 23 - 	- 24 - 
- 25 - 	- 26 - 	- 27 - 	- 28 - 
- 29 - 	- 30 - 	- 31 - 	- 32 - 

SWEBOLT AB

TEL. 08-584 909 60 FAX. 08-583 581 82

- 33 - 	- 34 - 	- 35 - 	- 36 - 
- 37 - 	- 38 - 	- 39 - 	- 40 - 
- 41 - 	- 42 - 	- 43 - 	- 44 - 
- 45 - 	- 46 - 	- 47 - 	- 48 - 
- 49 - 	- 50 - 	- 51 - 	- 52 - 
- 53 - 	- 54 - 	- 55 - 	- 56 - 
- 57 - 	- 58 - 	- 59 - 	- 60 - 
- 61 - 	- 62 - 	- 63 - 	- 64 - 

SWEBOLT AB

TEL. 08-584 909 60 FAX. 08-583 581 82

PRODUKTER I STÅL

1	13001	M6M, SEXKANTMUTTER	555	4034	6	OBEH	3:17
1	13002	M6M, SEXKANTMUTTER	555	4034	6	FZB	3:17
1	13003	M6M, SEXKANTMUTTER	555	4034	6	FZV	3:17
1	13010	M6M, SEXKANTMUTTER 0,8d	934		8	OBEH	3:1
1	13011	M6M, SEXKANTMUTTER 0,8d	934		8	FZB	3:1
1	13012	M6M, SEXKANTMUTTER 0,8d	934		8	FZV	3:1
1	13013	M6M, SEXKANTMUTTER 0,9d	970	4032	8	OBEH	3:1
1	13014	M6M, SEXKANTMUTTER 0,9d	970	4032	8	FZB	3:1
1	13015	M6M, SEXKANTMUTTER 0,9d	970	4032	8	FZV	3:1
1	13016	M6M, SEXKANTMUTTER 0,8d	934		10	OBEH	3:2
1	73017	M6M, SEXKANTMUTTER 0,8d	934		10	FZB/DEPO	3:2
1	13018	M6M, SEXKANTMUTTER 0,9d	970	4032	10	OBEH	3:2
1	73019	M6M, SEXKANTMUTTER 0,9d	970	4032	10	FZB/DEPO	3:2
1	13020	M6M, SEXKANTMUTTER 0,8d	934		12	OBEH	3:2
1	13021	M6M, SEXKANTMUTTER 0,9d	970	4032	12	OBEH	3:2
1	13022	VM6M, VÄNSTERGÄNGA	934		8	OBEH	3:2
1	13023	VM6M, VÄNSTERGÄNGA	934		8	FZB	3:2
1	13024	VM6M, VÄNSTERGÄNGA 0,9d	970	4032	8	OBEH	3:18
1	13025	VM6M, VÄNSTERGÄNGA 0,9d	970	4032	8	FZB	3:18
1	13026	VM6M, VÄNSTERGÄNGA 0,8d	934		10	OBEH	3:18
1	13029	VM6M, VÄNSTERGÄNGA 0,8d	934		10	FZV	3:18
1	13030	FM6M, FINGÄNGA	934		8	OBEH	3:7
1	13031	FM6M, FINGÄNGA	934		8	FZB	3:7
1	13032	FM6M, FINGÄNGA	970	4032	8	OBEH	3:7
1	13033	FM6M, FINGÄNGA	970	4032	8	FZB	3:7
1	13034	FM6M, FINGÄNGA	934		10	OBEH	3:7
1	73035	FM6M, FINGÄNGA	934		10	FZB/DEPO	3:7
1	13036	FM6M, FINGÄNGA	970	4032	10	OBEH	3:7
1	13037	VFM6M, FING., VÄNSTERG.	934		8	OBEH	3:18
1	13038	VFM6M, FING., VÄNSTERG.	934		8	FZB	3:18
1	13039	VFM6M, FING., VÄNSTERG.	970	4032	8	OBEH	3:18
1	13040	M6MSB, STÅLBYGGN.MUTTER	6915	7414	10	OBEH	3:6
1	73041	M6MSB, STÅLBYGGN.MUTTER	6915	7414	10	FZB/DEPO	3:6
1	13042	M6MSB, STÅLBYGGN.MUTTER	6915	7414	10	FZV	3:6
1	13043	M6M, SEXKANTMUTTER 1,0d		4033	8	OBEH	3:17
1	13044	M6M, SEXKANTMUTTER 1,0d		4033	8	FZB	3:17
1	13045	M6M, SEXKANTMUTTER 1,0d		4033	10	OBEH	3:17
1	73046	M6M, SEXKANTMUTTER 1,0d		4033	10	FZB/DEPO	3:17
1	13047	M6M, SEXKANTMUTTER 1,0d		4033	12	OBEH	3:17
1	13050	U6M, SEXKANTMUTTER	UNC		8	OBEH	3:31
1	13051	U6M, SEXKANTMUTTER	UNC		8	FZB	3:31
1	13052	U6M, SEXKANTMUTTER	UNC		8	FZV	3:31
1	13055	FU6M, SEXKANTMUTTER	UNF		8	OBEH	3:31
1	13056	FU6M, SEXKANTMUTTER	UNF		8	FZB	3:31

SWEBOLT AB

TEL. 08-584 909 60 FAX. 08-583 581 82

BILD	ART.GR.	BENÄMNING	DIN	ISO	KVAL	YTBEH	SIDA
1	13058	RM6M, RÖRGÄNGA	~934	~4033	6	OBEH	3:32
1	13060	RM6M, RÖRGÄNGA	431		6	OBEH	3:33
1	13061	RM6M, RÖRGÄNGA	431		6	FZB	3:33
1	13062	B6M, SEXKANTMUTTER	WITHW+BSF		8	OBEH	3:32
1	13063	B6M, SEXKANTMUTTER	WITHW+BSF		8	FZB	3:32
1	13064	B6M, SEXKANTMUTTER	WITHW+BSF		8	FZV	3:32
2	13065	ML6M, LÅG SEXKANTMUTTER	936		6	OBEH	3:5
2	13066	ML6M, LÅG SEXKANTMUTTER	936		6	FZB	3:5
2	13067	ML6M, LÅG SEXKANTMUTTER	936		6	FZV	3:5
2	13070	VML6M, LÅG, VÄNSTERG.	936/439B 4035		6	OBEH	3:5
2	13071	VML6M, LÅG, VÄNSTERG.	936/439B 4035		6	FZB	3:5
2	13075	FML6M, FINGÄNGA	936/439B 4035		6	OBEH	3:8
2	13076	FML6M, FINGÄNGA	936/439B 4035		6	FZB	3:8
2	13085	ML6M, LÅG SEXKANTMUTTER	439B	4035	6	OBEH	3:5
2	13086	ML6M, LÅG SEXKANTMUTTER	439B	4035	6	FZB	3:5
2	13087	ML6M, LÅG SEXKANTMUTTER	439B	4035	6	FZV	3:5
2	13090	UL6M, LÅG SEXKANTMUTTER	UNC		6	OBEH	3:31
2	13091	UL6M, LÅG SEXKANTMUTTER	UNC		6	FZB	3:31
2	13095	FUL6M, LÅG SEXKANTMUTTER	UNF		6	OBEH	3:31
2	13096	FUL6M, LÅG SEXKANTMUTTER	UNF		6	FZB	3:31
3	13100	LM6M, NYLONLÅSMUTTER	985	10511	6-8	FZB	3:3
3	13101	LM6M, NYLONLÅSMUTTER	985	10511	10	FZB/DEPO	3:3
3	13102	FLM6M, FINGÄNGAD LÅSM.	985	10511	8	FZB	3:8
3	13107	FLM6M, FINGÄNGAD LÅSM.	985	10511	10	FZB/DEPO	3:8
3	13105	LU6M, NYLONLÅSMUTTER	UNC		8	FZB	3:31
3	13106	FLU6M, NYLONLÅSMUTTER	UNF		8	FZB	3:31
4	13103	LM6MH, NYLONLÅSMU., HÖG	982		8	FZB	3:3
4	13104	LM6MH, NYLONLÅSMU., HÖG	982		10	FZB/DEPO	3:3
4	13108	LM6MH, HÖG LÅSMUTTER	6924	7040	8	FZB	3:3
4	13109	LM6MH, HÖG LÅSMUTTER	6924	7040	10	FZB/DEPO	3:3
4	13110	LU6MH, HÖG LÅSMUTTER	UNC		8	FZB	3:31
4	13111	FLU6MH, HÖG LÅSMUTTER	UNF		8	FZB	3:31
4	13116	FLM6MM, FINGÄNGA, NYLOCK	~982		8	FZB	3:19
5	13120	HLM6M, HELMET. LÅSMUTTER	980	7042	8	OBEH	3:4
5	13121	HLM6M, HELMET. LÅSMUTTER	980	7042	8	FZB	3:4
5	13122	HLM6M, HELMET. LÅSMUTTER	980	7042	8	FZV	3:4
5	13123	FHLM6M, HELMET. FINGÄNGA	980	7042	8	FZB	3:4
5	13126	HLM6M, HELMET. LÅSMUTTER	980	7042	10	FZB/DEPO	3:4
5	13127	FHLM6M, HELMET. FINGÄNGA	980		10	FZB/DEPO	3:4
1	13117	HLM6M, HELMET. LÅSMUTTER	6925		8	OBEH	3:4
1	13118	HLM6M, HELMET. LÅSMUTTER	6925		8	FZB	3:4
1	13119	HLM6M, HELMET. LÅSMUTTER	6925		8	FZV	3:4

SWEBOLT AB

TEL. 08-584 909 60 FAX. 08-583 581 82

BILD	ART.GR.	BENÄMNING	DIN	ISO	KVAL	YTBEH	SIDA
6	13132	MKM, KRONMUTTER	939		04	OBEH	3:9
6	13133	MKM, KRONMUTTER	939		04	FZB	3:9
6	13130	MKM, KRONMUTTER	935		6	OBEH	3:9
6	13131	MKM, KRONMUTTER	935		6	FZB	3:9
6	13135	MKM, KRONMUTTER	935		8	OBEH	3:9
6	13136	MKM, KRONMUTTER	935		8	FZB	3:9
6	13140	FMKM, FING. KRONMUTTER	935		8	OBEH	3:9
6	13141	FMKM, FING. KRONMUTTER	935		8	FZB	3:9
6	13145	MKM, KRONMUTTER	935		10	OBEH	3:9
6	13155	UKM, KRONMUTTER	UNC		8	OBEH	3:35
6	13156	UKM, KRONMUTTER	UNC		8	FZB	3:35
6	13160	FUKM, KRONMUTTER	UNF		8	OBEH	3:35
6	13161	FUKM, KRONMUTTER	UNF		8	FZB	3:35
7	13150	MLKM, LÅG KRONMUTTER	937		8	OBEH	3:20
7	13151	MLKM, LÅG KRONMUTTER	937		8	FZB	3:20
7	13158	FMLKM, LÅG KRONMU., FING.	937		8	OBEH	3:20
7	13159	FMLKM, LÅG KRONMU., FING.	937		8	FZB	3:20
8	13170	MHM, HATTMUTTER	1587		6	OBEH	3:10
8	13171	MHM, HATTMUTTER	1587		6	FZB	3:10
8	13172	FMHM, FING. HATTMUTTER	1587			OBEH	3:21
8	13173	FMHM, FING. HATTMUTTER	1587			FZB	3:21
8	13175	UHM, HATTMUTTER	UNC		6	OBEH	3:33
8	13176	UHM, HATTMUTTER	UNC		6	FZB	3:33
8	13180	FUHM, HATTMUTTER	UNF		6	OBEH	3:33
8	13181	FUHM, HATTMUTTER	UNF		6	FZB	3:33
9	13182	MHMP, HATTMU., PLÅTKAPSEL	~1587			OBEH	3:21
9	13183	MHMP, HATTMU., PLÅTKAPSEL	~1587			FZB	3:21
10	13185	MLHM, LÅG HATTMUTTER	917		6	OBEH	3:21
10	13186	MLHM, LÅG HATTMUTTER	917		6	FZB	3:21
10	13187	FMLHM, FING. L. HATTMUTTER	917		6	OBEH	3:21
10	13188	FMLHM, FING. L. HATTMUTTER	917		6	FZB	3:21
11	13190	LMHM, HATTM. m. NYLONLÅSR.	986			OBEH	3:21
11	13191	LMHM, HATTM. m. NYLONLÅSR.	986			FZB	3:21
12	13200	MVM, VINGMUTTER ADDUC	315			OBEH	3:10
12	13201	MVM, VINGMUTTER ADDUC	315			FZB	3:10
12	13205	UVM, VINGMUTTER	UNC			OBEH	3:34
12	13206	UVM, VINGMUTTER	UNC			FZB	3:34
13	13202	VM-A, VINGMUTTER AM-TYP				OBEH	3:10
13	13203	VM-A, VINGMUTTER AM-TYP				FZB	3:10
14	13215	SVM4M, SVETSMUTTER 4-KANT	928			OBEH	3:11
15	13216	SVM6M, SVETSMUTTER 6-KANT	929			OBEH	3:11
16	13220	M4M, FYRKANTMUTTER	557			OBEH	3:10
16	13221	M4M, FYRKANTMUTTER	557			FZB	3:10

SWEBOLT AB

TEL. 08-584 909 60 FAX. 08-583 581 82

BILD	ART.GR.	BENÄMNING	DIN	ISO	KVAL	YTBEH	SIDA
17	13225	ML4M, LÅG FYRKANTMUTTER	562			OBEH	3:10
17	13226	ML4M, LÅG FYRKANTMUTTER	562			FZB	3:10
18	13230	M6MH, SKARVMUTTER 6-KANT				OBEH	3:12
18	13231	M6MH, SKARVMUTTER 6-KANT				FZB	3:12
18	13232	M6MH, SKARVMUTTER 6-KANT				FZV	3:12
18	13236	M6MH, SKARVMUTTER 3 x D	6334		8-10	OBEH	3:12
18	13237	M6MH, SKARVMUTTER 3 x D	6334		8-10	FZB	3:12
18	13238	U6MH, SKARVMUTTER	UNC			OBEH	3:34
18	13239	U6MH, SKARVMUTTER	UNC			FZB	3:34
19	13232	M6MH, SKARVMUTTER 1,5 x D	6330		8-10	OBEH	3:12
19	13233	M6MH, SKARVMUTTER 1,5 x D	6330		8-10	FZB	3:12
20	13234	M6MHF, 1,5 x D m. FLÄNS	6331		8-10	OBEH	3:12
20	13235	M6MHF, 1,5 x D m. FLÄNS	6331		8-10	FZB	3:12
21	13241	M6MF, FLÄNSMUTTER	6923	4161	8	FZB	3:9
21	13242	M6MF, FLÄNSMUTTER	6923	4161	10	FZB	3:9
21	13401	KOMBIMUTTER (mutter+bricka)				FZB	3:22
	13280	KM, KULLAGERMUTTER	981				
	13281	AXELMUTTER	1804				
22	13291	VERBUS RIPP			10	FZB	3:30
22	13296	M6MFT, TENSILOCK	~6923		8	FZB	3:9
23	13245	LM6MF, FLÄNSLÅSMUTTER	6926	7073	8	FZB	3:9
24	13248	HLM6MF, HELMET. FLÄNSLÅSMU	6927	7044	8	FZB	3:19
25	13250	PALM, PALMUTTER	7967	1479		OBEH	3:16
25	13251	PALM, PALMUTTER	7967	1479		FZB	3:16
26	13255	RM, RUND LÄTTRAD MUTTER	466			OBEH	3:23
26	13256	RM, RUND LÄTTRAD MUTTER	466			FZB	3:23
27	13260	LRM, LÅG RUND LÄTTRAD MU.	467			OBEH	3:23
27	13261	LRM, LÅG RUND LÄTTRAD MU.	467			FZB	3:23
28	13265	RMS, RUND SLITSMUTTER	546			OBEH	3:23
28	13266	RMS, RUND SLITSMUTTER	546			FZB	3:23
29	13270	RMH, RUNDMU. m. SPÄNT HÅL	547			OBEH	3:23
29	13271	RMH, RUNDMU. m. SPÄNT HÅL	547			FZB	3:23
30	13275	RMSH, RUNDMU. m. SIDOHÅL	548			OBEH	3:24
30	13276	RMSH, RUNDMU. m. SIDOHÅL	548			FZB	3:24
31	13280	LM, LÅSMUTTER FÖR AXEL				OBEH	3:27
31	13281	LM, LÅSMUTTER FÖR AXEL				FZB	3:27
32	13290	PMA, PRESSMUTTER (ANCOR)				OBEH	3:25

SWEBOLT AB

TEL. 08-584 909 60 FAX. 08-583 581 82

BILD	ART.GR.	BENÄMNING	DIN	ISO	KVAL	YTBEH	SIDA
32	13291	PMA, PRESSMUTTER (ANCOR)				FZB	3:25
33	13295	PM, PRESSMUTTER				OBEH	3:25
33	13296	PM, PRESSMUTTER				FZB	3:25
34	13310	PMK, PRESSMUTTER (KALEI)				OBEH	3:25
34	13311	PMK, PRESSMUTTER (KALEI)				FZB	3:25
34	13212	NM, NITMUTTER				OBEH	3:25
34	13213	NM, NITMUTTER				FZB	3:25
35	13300	RSM, SVETSMU. VÅRTA UNDERSIDA TYP "A"				OBEH	3:13
35	13301	RSM, SVETSMU. VÅRTA UNDERSIDA TYP "A"				FZB	3:13
36	13302	RSM, SVETSMU. VÅRTA ÖVERSIDA TYP "B"				OBEH	3:13
36	13303	RSM, SVETSMU. VÅRTA ÖVERSIDA TYP "B"				FZB	3:13
37	13304	RSM, SVETSMU. PLAN TYP "C"				OBEH	3:14
37	13305	RSM, SVETSMU. PLAN TYP "C"				FZB	3:14
38	13306	RSM, SVETSMU. HÅL TYP "D"				OBEH	3:14
38	13307	RSM, SVETSMU. HÅL TYP "D"				FZB	3:14
39	13315	SPEEDNUTS		FST		OBEH	3:29
39	13316	SPEEDNUTS		FST		FZB	3:29
40	13320	TM, T-SPÅRMUTTER	508			OBEH	3:24
40	13321	TM, T-SPÅRMUTTER	508			FZB	3:24
41	13330	MFM, FÖRSÄNKT MUTTER 110°				OBEH	3:24
41	13331	MFM, FÖRSÄNKT MUTTER 110°				FZB	3:24
42	13600	KOM, KORGMUTTER				OPBEH	3:26
42	13601	KOM, KORGMUTTER				A2/FZG	3:26
43	13520	IS, ISLAGSMUTTER				OBEH	3:11
43	13521	IS, ISLAGSMUTTER				FZB	3:11
44	13530	FM, FJÄDERMUTTER, KORT				FZB	3:28
44	13531	FM, FJÄDERMUTTER, LÅNG				FZB	3:28
45	13820	M4MH, FYRKANT SKARVMUTTER				OBEH	3:12
45	13821	M4MH, FYRKANT SKARVMUTTER				FZB	3:12
45	13822	M4MH, FYRKANT SKARVMUTTER				FZV	3:12
46	13830	MRMH, RUND SKARVMUTTER				OBEH	3:12
46	13831	MRMH, RUND SKARVMUTTER				FZB	3:12
46	13832	MRMH, RUND SKARVMUTTER				FZV	3:12
47	13280	KM, KULLAGERLÅSMUTTER	1804			OBEH	3:29
47	13285	LKM, KULLAGERLÅSMUTTER m. NYLONRING					3:30
48	13701	HM, HJULMUTTER	74361A		8	FZB	3:22
49	13706	HMF, HJULMUTTER m. FLÄNS	74361B		8	FZB	3:22

SWEBOLT AB

TEL. 08-584 909 60 FAX. 08-583 581 82

BILD	ART.GR.	BENÄMNING	DIN	ISO	KVAL	YTBEH	SIDA
49	13708	HMF, HJULMUTTER m. FLÄNS	74361B		10	FZB	3:22
50	13840	KOMBIM6M m LÅSBRICKA			8	OBEH	
50	13841	KOMBIM6M m LÅSBRICKA			8	FZB	
51	13850	KOMBIM6M m BRICKA			8	OBEH	
51	13851	KOMBIM6M m BRICKA			8	FZB	

ROSTFRITT / SYRAFAST

1	23010	M6M, SEXKANTMUTTER	934		A2		3:40
1	23011	M6M, SEXKANTMUTTER	934		A4-80		3:40
1	23012	M6M, SEXKANTMUTTER		4032	A2		3:43
1	23013	M6M, SEXKANTMUTTER		4032	A4-80		3:43
1	23016	M6M, SEXKANTMUTTER	934	4032	A2	FZB	3:43
1	23017	M6M, SEXKANTMUTTER	934	4032	A4-80	FZB	3:43
1	23030	FM6M, SEXKANTMUTTER, FING.			A2		3:43
1	23031	FM6M, SEXKANTMUTTER, FING.			A4		3:43
1	23050	U6M, SEXKANTMUTTER	UNC		A2		3:49
1	23051	U6M, SEXKANTMUTTER	UNC		A4		3:49
1	23060	RML6M, RÖRGÄNGA	431		A2		3:49
1	23061	RML6M, RÖRGÄNGA	431		A4		3:49
2	23085	ML6M, LÅGMUTTER	439	4035	A2		3:40
2	23086	FML6M, LÅGMUTTER, FING.	439	4035	A4		3:40
2	23090	UL6M, LÅGMUTTER	UNC		A2		3:48
3	23100	LM6M, NYLONLÅSMUTTER	985	10511	A2		3:40
3	23101	LM6M, NYLONLÅSMUTTER	985	10511	A4-80		3:40
3	23102	LM6M, NYLONLÅSMUTTER	985	10511	A2	FZB	3:43
3	23103	LM6M, NYLONLÅSMUTTER	985	10511	A4	FZB	3:43
4	23103	LM6MH, NYLONLÅSM, HÖG	982		A2		3:44
4	23104	LM6MH, NYLONLÅSM, HÖG	982		A4		3:44
3	23105	LU6M, NYLONLÅSMUTTER	UNC		A4		3:49
5	23120	HLM6M, HELMET. LÅSMUTTER	980		A2		3:42
5	23121	HLM6M, HELMET. LÅSMUTTER	980		A4		3:42
6	23130	MKM, KRONMUTTER	935		A2		3:42
6	23131	MKM, KRONMUTTER	935		A4		3:42
7	23150	MLKM, LÅG KRONMUTTER	937		A2		3:44
7	23151	MLKM, LÅG KRONMUTTER	937		A4		3:44
8	23170	MHM, HATTMUTTER	1587		A2		3:41
8	23171	MHM, HATTMUTTER	1587		A4		3:41
10	23185	MLHM, LÅG HATTMUTTER	917		A2		3:44
10	23186	MLHM, LÅG HATTMUTTER	917		A4		3:44
13	23200	VM-A, VINGMUTTER, AM-TYP			A2		3:41

SWEBOLT AB

TEL. 08-584 909 60 FAX. 08-583 581 82

BILD	ART.GR.	BENÄMNING	DIN	ISO	KVAL	YTBEH	SIDA
13	23201	VM-A, VINGMUTTER, AM-TYP			A4		3:41
15	23216	SVM6M, SVETSMUTTER	929		A2		3:41
15	23217	SVM6M, SVETSMUTTER	929		A4		3:41
16	23220	M4M, 4-KANTMUTTER	557		A2		3:45
16	23221	M4M, 4-KANTMUTTER	557		A4		3:45
17	23225	ML4M, LÅG FYRKANTMUTTER	562		A2		3:42
17	23226	ML4M, LÅG FYRKANTMUTTER	562		A4		3:42
18	23230	M6MH, SKARVMUTTER, 6-KANT			A2		3:48
18	23231	M6MH, SKARVMUTTER, 6-KANT			A4		3:48
18	23232	M6MH, SKARVMUTTER 1,5 x D	6330		A2		3:48
18	23233	M6MH, SKARVMUTTER 1,5 x D	6330		A4		3:48
18	23236	M6MH, SKARVMUTTER 3 x D	6334		A2		3:48
20	23234	M6MHF, 1,5 x D m. FLÄNS	6331		A2		3:48
20	23235	M6MHF, 1,5 x D m. FLÄNS	6331		A4		3:48
21	23240	M6MF, FLÄNSMUTTER	6923		A2		3:50
21	23241	M6MF, FLÄNSMUTTER	6923		A4		3:50
22	23295	M6MFT, FLÄNSMUTTER TANDAD	~6923		A2		3:50
22	23296	M6MFT, FLÄNSMUTTER TANDAD	~6923		A4		3:50
25	23250	PALM, PALMUTTER	7967		A2		3:45
25	23251	PALM, PALMUTTER	7967		A4		3:45
26	23255	RM, RUND LÄTTRAD MUTTER	466		A2		3:45
26	23256	RM, RUND LÄTTRAD MUTTER	466		A4		3:45
27	23260	LRM, LÅG RUND LÄTTRAD MU.	467		A1		3:45
27	23261	LRM, LÅG RUND LÄTTRAD MU.	467		A4		3:45
28	23265	RMS, RUND SLITSMUTTER			A1		3:46
32	23290	PMA, PRESSMUTTER (ANCOR)			A1		3:46
33	23295	PM, PRESSMUTTER			A2		3:46
34	23310	PMK, PRESSMUTTER (KALEI)			A2		3:46
37	23300	RSM, SVETSMUTTER PLAN TYP "C"			A2		3:47
45	23820	4-KANT SKARVMUTTER			A2		3:48
45	23821	4-KANT SKARVMUTTER			A4		3:48
46	23830	RUND SKARVMUTTER			A2		3:48
46	23831	RUND SKARVMUTTER			A4		3:48
	23880	S-M6M, SÄKERHETSMUTTER			A2		3:50
1	23048	M6M, SEKKANTMUTTER 0,8d	934		DUPLEX		

MÄSSING

SWEBOLT AB

TEL. 08-584 909 60 FAX. 08-583 581 82

BILD	ART.GR.	BENÄMNING	DIN	ISO	KVAL	YTBEH	SIDA
1	33010	M6M, SEXKANTMUTTER 0,8d	934			OBEH	3:51
1	33011	M6M, SEXKANTMUTTER 0,8d	934			FÖRNICKLAD	3:51
1	33043	M6M, SEXKANTMUTTER 1,0d		4033		OBEH	3:53
1	33044	M6M, SEXKANTMUTTER 1,0d		4033		FÖRNICKLAD	3:53
2	33085	ML6M, LÅG SEXKANTMUTTER	439B	4035		OBEH	3:52
2	33086	ML6M, LÅG SEXKANTMUTTER	439B	4035		FÖRNICKLAD	3:52
2	33096	ML6M, LÅG ELEKTROMUTTER				FÖRNICKLAD	3:53
3	33100	LM6M, NYLONLÅSMUTTER	985	10511		OBEH	3:52
3	33101	LM6M, NYLONLÅSMUTTER	985	10511		FÖRNICKLAD	3:52
6	33130	MKM, KRONMUTTER	935			OBEH	3:52
6	33131	MKM, KRONMUTTER	935			FÖRNICKLAD	3:52
8	33170	MHM, HATTMUTTER	1587			OBEH	3:51
8	33171	MHM, HATTMUTTER	1587			FÖRNICKLAD	3:51
8	33172	MHM, HATTMUTTER	1587			FÖRKROMAD	3:51
10	33185	MLHM, LÅG HATTMUTTER	917			OBEH	3:54
10	33186	MLHM, LÅG HATTMUTTER	917			FÖRNICKLAD	3:54
12	33200	VM, VINGMUTTER ADDUC	315			OBEH	3:51
12	33201	VM, VINGMUTTER ADDUC	315			FÖRNICKLAD	3:51
18	33236	M6MH, SKARVMUTTER 3 x D	6334			OBEH	3:55
26	33255	RM, RUND LÄTTRAD MUTTER	466			OBEH	3:55
26	33256	RM, RUND LÄTTRAD MUTTER	466			FÖRNICKLAD	3:55
27	33260	LRM, LÅG R. LÄTTRAD MUTTER	467			OBEH	3:55
27	33261	LRM, LÅG R. LÄTTRAD MUTTER	467			FÖRNICKLAD	3:55
28	33265	RMS, RUND SLITSMUTTER	546			OBEH	3:55
28	33266	RMS, RUND SLITSMUTTER	546			FÖRNICKLAD	3:55

POLYAMID

1	43001	M6M, SEXKANTMUTTER	555	4034			3:90
1	43010	M6M, SEXKANTMUTTER	934				3:90
8	43170	MHM, HATTMUTTER	1587				3:90
12	43200	VM, VINGMUTTER	315				3:91
26	43255	RM, RUND LÄTTRAD MUTTER	466				3:91
27	43260	LRM, LÅG RUND LÄTTRAD MU.	467				3:91

KOPPAR

1	53010	M6M, SEXKANTMUTTER	934				3:70
---	-------	--------------------	-----	--	--	--	------

SWEBOLT AB

TEL. 08-584 909 60 FAX. 08-583 581 82

<u>BILD</u>	<u>ART.GR.</u>	<u>BENÄMNING</u>	<u>DIN</u>	<u>ISO</u>	<u>KVAL</u>	<u>YTBEH</u>	<u>SIDA</u>
<u>ALUMINIUM</u>							
1	63010	M6M, SEXKANTMUTTER	934				3:80
8	63170	MHM, HATTMUTTER	1587				3:80
10	63185	MLHM, LÅG HATTMUTTER	917				3:81
32	63290	PMA, PRESSMUTTER (ANCOR)					3:81
<u>TITAN</u>							
1	73010	M6M, SEXKANTMUTTER 0,8d	934				3:95

SWEBOLT AB

TEL. 08-584 909 60 FAX. 08-583 581 82

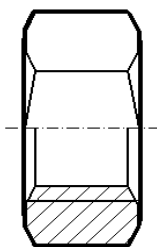

ARTIKELLISTA
2013-2014
MUTTER M6M
DIN 934 / ISO 4032
OBEH - FZB - FZV



M6M DIN 934					
C:A PRIS/100 ST					
DIM	NV	HÖJD	OBEH	FZB	FZV
M1	2.5	0.8		X	
M1.2	3	1		X	
M1.4	3	1.2		X	
M1.6	3.2	1.3		X	
M1.7	3.5	1.4		X	
M1.8	3.5	1.4		X	
M2	4	1.6		X	
M2.2	4.5	1.8		X	
M2.3	4.5	1.8		X	
M2.5	5	2		X	
M2.6	5	2		X	
M3	5.5	2.4		X	
M3.5	6	2.8		X	
M4	7	3.2	X	X	
M5	8	4	X	X	
M6	10	5	X	X	X
M7	11	5.5	X	X	
M8	13	6.5	X	X	X
M10	17	8	X	X	X
M12	19	10	X	X	X
M14	22	11	X	X	X
M16	24	13	X	X	X
M18	27	15	X	X	X
M20	30	16	X	X	X
M22	32	18	X	X	X
M24	36	19	X	X	X
M27	41	22	X	X	X
M30	46	24	X	X	X
M33	50	26	X	X	X
M36	55	29	X	X	X
M39	60	31	X	X	X
M42	65	34	X	X	X
M45	70	36	X	X	X
M48	75	38	X	X	X
M52	80	42	X	X	X
M56	85	45	X	X	X
M60	90	48	X	X	X
M64	95	51	X	X	X

M6M ISO 4032					
C:A PRIS/100 ST					
DIM	NV	HÖJD	OBEH	FZB	FZV
M3	5.5	2.4			
M4	7	3.2			
M5	8	4.7			
M6	10	5.2		X	
M7	11	6.5			
M8	13	6.8		X	X
M10	16	8.4	X	X	X
M12	18	10.8	X	X	X
M14	21	12.8	X	X	X
M16	24	14.8	X	X	X
M18	27	15.8			X
M20	30	18	X	X	X
M22	34	19.4			X
M24	36	21.5	X	X	X
M27	41	23.8	X	X	X
M30	46	25.6	X	X	X
M33	50	28.7			X
M36	55	31		X	X
M42	65	37,8			X
FÖRP.	OBEH	FZB	FZV		
200 ST	M8-	M6-	M8-		
100 ST	M10-	M10-	M10-		
50 ST	M16-	M16-	M16-		
25 ST	M24-	M24-	M24-		
10 ST	M30-	M30-	M30-		

- 13010100 - M6M M10 OBEH DIN 934
- 13011100 - M6M M10 FZB DIN 934
- 13012100 - M6M M10 FZV DIN 934
- 13013100 - M6M M10 OBEH ISO 4032
- 13014100 - M6M M10 FZB ISO 4032
- 13015100 - M6M M10 FZV ISO 4032

BULK FÖRPACKNING				
C:A PRIS/100ST				
M6M DIN 934			M6M ISO 4032	
DIM	FZB	FZV	FZB	FZV
M6	X		X	
M8	X	X	X	X
M10	X	X	X	X
M12	X	X	X	X
M16	X	X	X	X
M20	X	X	X	X
M24	X	X	X	X
M27	X	X	X	X
M30	X	X	X	X

FÖRP.	OBEH	FZB	FZV
500 ST	M4-	M1-	
200 ST	M6-	M3-	M6-
100 ST	M10-	M10-	M10-
50 ST	M16-	M16-	M16-
25 ST	M24-	M24-	M24-
10 ST	M30-	M30-	M30-
5 ST	M42-		M39-

KRYSSMARKERADE ARTIKLAR MOT FÖRFRÅGAN !
 ÖVRIGA DIMENSIONER MOT FÖRFRÅGAN !

SWEBOLT AB

TEL 08 - 555 975 00 FAX 08 - 583 581 82



ARTIKELLISTA
2013-2014
MUTTER M6M, VM6M
DIN 934 / ISO 4032
KVALITET 10-12
VÄNSTERGÅNGA KV8

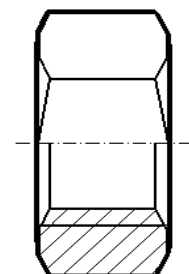

DIN 934							
C:A PRIS/100 ST							
DIM	KVALITET ==>		10		12	VÄNSTER	
	NV	HÖJD	OBEH	FZB / DEPO	OBEH	OBEH	FZB
M3	5.5	2.4	X				
M4	7	3.2	X			X	
M5	8	4	X				
M6	10	5	X	X	X		X
M7	11	5.5	X				
M8	13	6.5	X	X	X	X	X
M10	17	8	X	X	X		X
M12	19	10	X	X	X		X
M14	22	11	X	X	X	X	X
M16	24	13	X	X	X		X
M18	27	15	X	X	X		
M20	30	16	X	X	X	X	X
M22	32	18	X	X	X		
M24	36	19	X	X	X	X	X
M27	41	22	X		X	X	
M30	46	24	X		X	X	
M33	50	26	X				
M36	55	29	X		X	X	
M39	60	31	X				
M42	65	34	X			X	
M45	70	36			X		
M48	75	38	X				

ISO 4032					
C:A PRIS/100 ST					
DIM	KVALITET ==>		10		12
	NV	HÖJD	OBEH	FZB / DEPO	OBEH
M3	5.5	2.4			
M4	7	3.2			
M5	8	4.7			
M6	10	5.2			
M7	11	6.5			
M8	13	6.8			
M10	16	8.4			
M12	18	10.8	X		
M14	21	12.8			
M16	24	14.8	X		
M18	27	15.8			
M20	30	18			
M22	34	19.4			
M24	36	21.5			
M27	41	23.8			
M30	46	25.6	X		
M33	50	28.7			
M36	55	31	X		

FÖRP.	SAMTLIGA
500 ST	M3-
200 ST	M6-
100 ST	M10-
50 ST	M16-
25 ST	M24-
10 ST	M30-
5 ST	M39-

ÖVRIGA DIMENSIONER MOT FÖRFRÅGAN !

BESTÄLLNINGSEXEMPEL: 13016100 = M6M M10 8 OBEH DIN 934
 BESTÄLLNINGSEXEMPEL: 73017100 = M6M M10 8 FZB/DEPO DIN 934
 BESTÄLLNINGSEXEMPEL: 13020100 = M6M M10 12 OBEH DIN 934
 BESTÄLLNINGSEXEMPEL: 13022100 = VM6M M10 OBEH DIN 934
 BESTÄLLNINGSEXEMPEL: 13023100 = VM6M M10 FZB DIN 934
 BESTÄLLNINGSEXEMPEL: 13013100 = M6M M10 OBEH DIN 934
 BESTÄLLNINGSEXEMPEL: 13018100 = M6M M10 OBEH ISO 4032
 BESTÄLLNINGSEXEMPEL: 73019100 = M6M M10 10 FZB/DEPO ISO 4032
 BESTÄLLNINGSEXEMPEL: 13021100 = M6M M10 12 OBEH ISO 4032

ARTIKELLISTA

2013-2014

LÅSMUTTER LM6M/LM6MH/LM6MH

DIN 985/DIN 982/DIN 6924

KVALITET 8-10

FZB

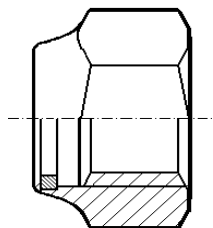

LM6M DIN 985					LM6MH DIN 982					LM6MH DIN 6924				
C:A PRIS/100 ST					C:A PRIS/100 ST					C:A PRIS/100 ST				
DIM	NV	Höjd	FZB	10 FZB	DIM	NV	Höjd	FZB	10 FZB	DIM	NV	Höjd	FZB	FZV
M2	4.5	2.5	X											
M2.5	5	3.8	X											
M2.6	5	3.8												
M3	5.5	4	X		M3	5.5	4							
M4	7	5	X		M4	7	6			M4	7	6	X	
M5	8	5	X		M5	8	6.3			M5	8	6.8	X	
M6	10	6	X	X	M6	10	8			M6	10	8	X	
M7	11	7.5	X		M7	11	8.5			M7	11	9		
M8	13	8	X	X	M8	13	9.5	X		M8	13	9.5	X	X
M10	17	10	X	X	M10	17	11.5	X		M10	16	11.9	X	X
M12	19	12	X	X	M12	19	14	X		M12	18	14.9	X	X
M14	22	14	X	X	M14	22	16	X		M14	21	17	X	X
M16	24	16	X	X	M16	24	18	X	X	M16	24	19.1	X	X
M18	27	18.5	X	X	M18	27	20	X	X	M18	27	20.6		
M20	30	20	X	X	M20	30	22	X	X	M20	30	22.8	X	X
M22	32	22	X	X	M22	32	25	X		M22	32	24.5		
M24	36	24	X	X	M24	36	28			M24	36	27.1	X	X
M27	41	27	X	X	M27	41	30			M27	41	31		
M30	46	30	X	X	M30	46	35			M30	46	32.6		
M33	50	33	X	X						M33	50	35.5		
M36	55	36	X	X						M36	55	38.9		
M39	60	39	X											
M42	65	42	X											
M45	70	45												
M48	75	48	X											

ÖVRIGA DIMENSIONER MOT FÖRFRÅGAN !

FÖRP.	SAMTLIGA
500 ST	M2-
200 ST	M3-
100 ST	M10-
50 ST	M16-
25 ST	M24-
10 ST	M30-

BESTÄLLNINGSEXEMPEL:

13100120 - LM6M M12 FZB DIN 985

13101120 - LM6M M12 10 FZB DIN 985

13103120 - LM6MH M12 FZB DIN 982

13104120 - LM6MH M12 10 FZB DIN 982

13108120 - LM6MH M12 FZB DIN 6924

SWEBOLT AB

TEL 08 - 555 975 00 FAX 08 - 583 581 82

ARTIKELLISTA

2013-2014

MELMETALLISK LÅSMUTTER HLM6M

DIN 980V/DIN 6925

FZB - FZV

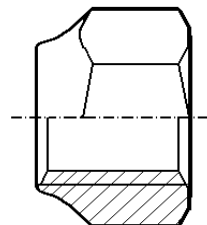

HLM6M DIN 980V						HLM6M DIN 6925				
C:A PRIS/100 ST						C:A PRIS/100 ST				
DIM	NV	Höjd	FZB	FZV	10 FZB DEPO	DIM	NV	Höjd	FZB	DEPO
M4	7	4	X			M4	7	4.2		
M5	8	5	X			M5	8	5.1		
M6	10	6	X			M6	10	6	X	X
M7	11	7				M7	11	7		
M8	13	8	X			M8	13	8	X	X
M10	17	10	X	X	X	M10	16	10	X	X
M12	19	12	X	X	X	M12	18	12	X	X
M14	22	14	X		X	M14	21	14	X	X
M16	24	16	X	X	X	M16	24	16	X	X
M18	27	18	X		X	M18	27	18		
M20	30	20	X		X	M20	30	20	X	X
M22	32	22	X		X	M22	34	22		
M24	36	24	X		X	M24	36	24	X	X
M27	41	27	X			M27	41	27		X
M30	46	24	X			M30	46	30	X	X
M33	50	33	X			M33	50	33		
M36	55	36	X			M36	55	36		

FÖRP.	SAMTLIGA
200 ST	M4-
100 ST	M10-
50 ST	M16-
25 ST	M24-
10 ST	M30-

ÖVRIGA DIMENSIONER MOT FÖRFÅGAN !

OBS! HÖJDMÅTT KAN VARIERA NÅGOT MELLAN OLIKA TILLVERKARE.

BESTÄLLNINGSEXEMPEL:

13121100 - HLM6M M10 FZB DIN 980V

13122100 - HLM6M M10 FZV DIN 6925

13118100 - HLM6M M10 FZB DIN 6925

73118100 - HLM6M M10 DEPO DIN 6925

13126100 - HLM6M M12 -10 FZB DIN 980V

SWEBOLT AB

TEL 08-555 975 00 FAX 08-583 581 82

ARTIKELLISTA

2013-2014

LÅG MUTTER ML6M

DIN 936 - DIN 936 VÄNSTER - DIN 439B - ISO 4035

OBEH - FZB - FZV

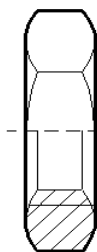

ML6M DIN 936							
C:A PRIS/100ST						VÄNST	VÄNST
DIM	NV	Höjd	OBEH	FZB	FZV	OBEH	FZB
M6	10	3.2					X
M8	13	5	X	X	X	X	X
M10	17	6	X	X	X	X	X
M12	19	7	X	X	X	X	X
M14	22	8	X	X	X	X	X
M16	24	8	X	X	X	X	X
M18	27	9	X	X		X	X
M20	30	9	X	X	X	X	X
M22	32	10	X	X		X	X
M24	36	10	X	X	X	X	X
M27	41	12	X	X	X	X	X
M30	46	12	X	X	X	X	X
M33	50	14	X	X	X		
M36	55	14	X	X	X		
M39	60	16	X				
M42	65	16	X				
M45	70	18	X				
M48	75	18	X				
M52	80	20	X				

ML6M DIN 439B							
C.A PRIS/100 ST							
DIM	NV	Höjd	OBEH	FZB	FZV		
M2	4	1.2	X	X			
M2.5	5	1.6	X	X			
M2.6	5	1.6		X			
M3	5.5	1.8	X	X			
M4	7	2.2	X	X			
M5	8	2.7	X	X			
M6	10	3.2	X	X			
M8	13	4	X	X			
M10	17	5	X	X			
M12	19	6	X	X	X		
M14	22	7	X	X			
M16	24	8	X	X	X		
M18	27	9	X	X			
M20	30	10	X	X	X		
M22	32	11	X	X			
M24	36	12	X	X	X		
M27	41	13.5	X	X	X		
M30	46	15	X	X	X		
M33	50	16.5	X	X			
M36	55	18	X	X			

KRYSSMARKERADE ARTIKLAR MOT FÖRFRÅGAN !

FÖRP.	SAMTLIGA
500 ST	M2-
200 ST	M5-
100 ST	M12-
50 ST	M20-
25 ST	M30-

ML6M ISO 4035			
C.A PRIS/100 ST			
DIM	NV	Höjd	FZB
M10	16	5	X
M12	18	6	X

BESTÄLLNINGSEXEMPEL:

- 13065100 - ML6M M10 OBEH DIN 936
- 13066100 - ML6M M10 FZB DIN 936
- 13067100 - ML6M M10 FZV DIN 936
- 13085100 - ML6M M10 OBEH DIN 439B
- 13086100 - ML6M M10 FZB DIN 439B
- 13070100 - VML6M M10 OBEH DIN 936 VÄNSTER
- 13071100 - VML6M M10 FZB DIN 936 VÄNSTER
- 13088100 - ML6M M10 FZB ISO 4035

SWEBOLT AB

TEL 08-555 975 00 FAX 08-583 581 82

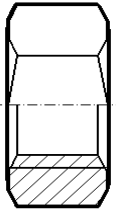

ARTIKELLISTA

2013-2014

MUTTER FINGÄNGA FM6M

DIN 934 - ISO 4032

KVALITET 8-10 OBEH-FZB



DIN 934							ISO 4032					
C:A PRIS/100ST							C:A PRIS/100 ST					
KVALITET			8		10		KVALITET			8		10
DIM	NV	Höjd	OBEH	FZB	OBEH	FZB	DIM	NV	Höjd	OBEH	FZB	OBEH
M4x0.5	7	3.2					M4x0.5	7	3.2			
M5x0.5	8	4					M5x0.5	8	4			
M6x0.75	10	5	X	X			M6x0.75	10	5			
M8x0.75	10	5	X	X			M8x1	13	5.2			
M8x1	13	6.5	X	X			M10x1	16	8.4			
M10x1	17	8	X	X	X		M10x1.25	16	8.4			
M10x1.25	17	8	X	X	X		M12x1	18	10.8			
M12x1	19	10	X	X			M12x1.25	18	10.8			
M12x1.25	19	10	X	X			M12x1.5	18	10.8			
M12x1.5	19	10	X	X			M14x1.25	21	12.8			
M14x1.25	22	11	X	X			M14x1.5	21	12.8			
M14x1.5	22	11	X	X			M16x1	24	14.8			
M16x1	24	13	X				M16x1.5	24	14.8			
M16x1.5	24	13	X	X	X		M18x1.5	27	15.8			
M18x1.5	27	15	X	X	X		M20x1.5	30	18			
M20x1	30	16	X				M20x2	30	18			
M20x1.5	30	16	X	X	X		M22x1.5	34	19.4			
M20x2	30	16	X	X			M22x2	34	19.4			
M22x1.5	32	18	X	X	X		M24x1.5	36	21.5			
M22x2	32	18	X				M24x2	36	21.5			
M24x1.5	36	19	X	X			M27x1.5	41	23.8			
M24x2	36	19	X	X			M27x2	41	23.8			
M27x1.5	41	22	X				M30x1.5	46	25.6			
M27x2	41	22	X	X			M30x2	46	25.6			
M30x1.5	46	24	X				M33x1.5	50	38.7			
M30x2	46	24	X	X			M33x2	50	38.7			
M33x1.5	50	26	X				M36x1.5	55	31			
M33x2	50	26	X				M36x2	55	31			
M36x1.5	55	29	X				M36x3	55	31			
M36x2	55	29	X				M39x2	60	32			
M36x3	55	29	X				M39x3	60	32			
M39x2	60	31	X				M42x1.5					
M39x3	60	31	X				M42x2					
M42x1.5	65	34	X				M42x3					
M42x2	65	34	X				M45x2					
M42x3	65	34	X				M45x3					
M45x2	70	36	X				M48x2					
M45x3	70	36	X				M56x4					
M48x2	75	38	X				M60x4					
M48x3	75	38	X									
M52x3	80	42	X									
M56x3	85	45	X									
M56x4	85	45	X									
M60x4	90	48	X									

FORP.	SAMTLIGA
200 ST	M4-
100 ST	M10-
50 ST	M22-
25 ST	M27-
10 ST	M33-

BESTÄLLNINGSEXEMPEL: 130301010 - FM6M M10x1.0 OBEH

BESTÄLLNINGSEXEMPEL: 130311010 - FM6M M10x1.0 FZB

BESTÄLLNINGSEXEMPEL: 130341010 - FM6M M10x1.0 -10 OBEH

ÖVRIGA DIMENSIONER MOT FÖRFRÅGAN !

SWEBOLT AB

ARTIKELLISTA

2013-2014

FINGÄNGAD LÅG MUTTER FML6M DIN 936/439B

FINGÄNGAD LÅSMUTTER FLM6M DIN 985

KVALITET 8-10

OBEH - FZB

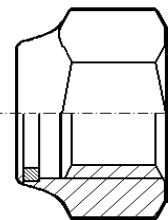
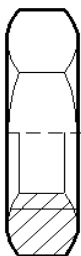

FML6M DIN 936					FML6M DIN 439B			FLM6M DIN 985			
C:A PRIS/100 ST					C:A PRIS/100 ST			C:A PRIS/100 ST			
DIM	NV	Höjd	OBEH	FZB	NV	Höjd	FZB	NV	Höjd	FZB	10 FZB
M4x0.5	7				7	2.2		7	5		
M5x0.5	8	3			8	2.7		8	5		
M6x0.75	10	4			10	3.2		10	6		
M8x1	13	5	X		13	4	X	13	8	X	
M10x1	17	6	X		17	5	X	17	10	X	X
M10x1.25	17	6	X		17	5	X	17	10	X	
M12x1	19	7			19	6	X	19	12	X	
M12x1.25	19	7	X		19	6	X	19	12	X	
M12x1.5	19	7	X		19	6	X	19	12	X	
M14x1.25	22	8	X		22	7		22	14		
M14x1.5	22	8	X	X	22	7		22	14	X	X
M16x1.5	24	8	X	X	24	8		24	16	X	
M18x1.5	27	9	X	X	27	9		27	18	X	
M20x1.5	30	9	X	X	30	10		30	20	X	
M20x2	30	9	X	X	30	10		30	20		
M22x1.5	32	10			32	11	X	32	22	X	
M22x2	32	10		X	32	11		32	22		
M24x1.5	36	10	X	X	36	12		36	24	X	X
M24x2	36	10	X	X				36	24	X	
M27x1.5	41	12						41	27		
M27x2	41	12		X				41	27	X	
M30x1.5	46	12	X	X	46	15		46	30	X	
M30x2	46	12	X	X				46	30	X	
M33x1.5	50	14						50	33		
M33x2	50	14	X					50	33	X	
M36x1.5	55	14						55	36	X	
M36x2	55	14	X	X				55	36		
M36x3	55	14						55	36	X	
M39x2	60	16						60	39		
M39x3	60	16						60	39		
M42x1.5	65	16						65	42		
M42x2	65	16						65	42		
M42x3	65	16					X	65	42	X	

FÖRP.	SAMTLIGA
200 ST	M4-
100 ST	M14-
50 ST	M24-
25 ST	M30-

ÖVRIGA DIMENSIONER MOT FÖRFRÅGAN !

BESTÄLLNINGSEXEMPEL:

130751415 - FML6M M14X1.5 OBEH DIN 936

130761415 - FML6M M14X1.5 FZB DIN 936

131021415 - FLM6M M14X1.5 FZB DIN 985

131071415 - FLM6M M14X1.5 -10 FZB DIN 985

SWEBOLT AB

TEL 08-555 975 00 FAX 08-583 581 82

ARTIKELLISTA

2013-2014

FLÄNSMUTTER M6MF DIN 6923 FLÄNSMUTTER RÄFFLAD M6MFT FLÄNSLÅSMUTTER LM6MF DIN 6927

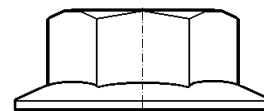
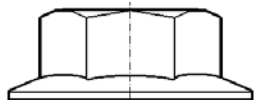

M6MF DIN 6923						M6MFT RÄFFLAD		LM6MF DIN 6927				
C:A PRIS/100 ST						PRIS/100 ST		C:A PRIS/100 ST				
DIM	NV	Höjd	Fläns diam	8 FZB	10 FZB	NV	8 FZB	NV	Höjd	Fläns diam	8 FZB	10 FZB
M4	7	5	10.2	X		7	X					
M5	8	5	11.8	X		8	X	8	5.5	11.8	X	
M6	10	6	14.2	X		10	X	10	7.3	14.2	X	
M8	13	8	17.9	X	X	13	X	13	9.4	17.9	X	
M10	15	10	21.8	X	X	15	X	15	11.4	21.8	X	
M12	18	12	26	X	X	18	X	18	13.8	26	X	
M14	21	14	29.9	X	X	21					X	
M16	24	16	34.5	X	X	24	X	24	18.3	34.5	X	
M20	30	20	42.8	X	X	30	X	30	22.4	42.8	X	
FORP				FZB	FZB		FZB				FZB	FZB
200 ST				M4-	M4-		M4-				M4-	M4-
100 ST				M10-	M10-		M10-				M10-	M10-
50 ST				M16-	M16-		M16-				M16-	M16-
25 ST				M20-	M20-		M20-				M20-	M20-

KRONMUTTER MKM DIN 935 FINGÄNGAD FMKM DIN 935

MKM DIN 935					
C:A PRIS/100 ST					
DIM	NV	Höjd	6 OBEH	6 FZB	8 FZB
M4	7	5			
M5	8	6			
M6	10	7.5		X	
M8	13	9.5		X	X
M10	17	12			
M12	19	15	X		
M14	22	16			
M16	24	19	X		X
M20	30	22			X
M24	36	27			X
M27	41	30			
M30	46	33	X		X
M33	50	35			
M36	55	38	X		X
M39	60	40			
M42	65	46	X		
M45	70	48	X		
M52	80	52			

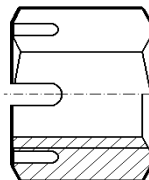

FRÅN M12
MED HALS

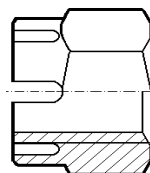

FMKM DIN 935		
C:A PRIS/100 ST		
DIM	OBEH	FZB
M8x1		
M10x1.25		
M12x1.5		
M14x1.5		
M16x1.5		
M18x2		
M20x1.5	X	
M20x2		
M22x2		
M24x2		
M27x2		
M30x1.5		
M30x2		

BESTÄLLNINGSEXEMPEL: 13241100 - M6MF M10 8 FZB
 BESTÄLLNINGSEXEMPEL: 13242120 - M6MF M12 10 FZB
 BESTÄLLNINGSEXEMPEL: 13296120 - M6MFT M12 FZB
 BESTÄLLNINGSEXEMPEL: 13245080 - LM6MF M8 FZB
 BESTÄLLNINGSEXEMPEL: 13130200 - MKM M20 6 OBEH
 BESTÄLLNINGSEXEMPEL: 13136200 - MKM M20 8 FZB

ÖVRIGA DIMENSIONER MOT FÖRFRÅGAN !

FÖRP	OBEH	FZB	FZB	OBEH	FZB
200 ST	M4-	M4-	M4-	M8-	M8-
100 ST	M10-	M10-	M10-	M10-	M10-
50 ST	M16-	M16-	M16-	M16-	M16-
25 ST	M24-	M24-	M24-	M24-	M24-

SWEBOLT AB

TEL 08 - 555 975 00 FAX 08 - 583 581 82

ARTIKELLISTA

2013-2014

4-KANTMUTTER ML4M DIN 562 - M4M DIN 557 HATTMUTTER MHM DIN 1587 OBEH - FZB



ML4M DIN 562				
C:A PRIS/100 ST				
DIM	NV	Höjd	OBEH	FZB
M3	5.5	1.8		X
M4	7	2.2		X
M5	8	2.7		X
M6	10	3.2		X
M8	13	4		X
M10	17	5		
M12				
M14				
M16				
M20				
M24				
M27				

M4M DIN 557				
C:A PRIS/100 ST				
DIM	NV	Höjd	OBEH	FZB
M3				
M4	7	3.2		X
M5	5	4		X
M6	10	5		X
M8	13	6.5		X
M10	17	8	X	X
M12	19	10		
M14	22	11		
M16	24	13		X
M20	30	16		
M24				
M27				

MHM DIN 1587				
C:A PRIS/100 ST				
DIM	NV	Höjd	OBEH	FZB
M3	5.5	6		X
M4	7	8		X
M5	8	10		X
M6	10	12		X
M8	13	15		X
M10	17	18		X
M12	19	22	X	X
M14	22	25		X
M16	24	28	X	X
M20	30	34		X
M24	36	42		X
M27	41	45		

FÖRP	OBEH	FZB	OBEH	FZB	OBEH	FZB
1000 ST		M4-				
200 ST		M6-		M6-		M3-
100 ST						M10-
50 ST						M16-



VINGMUTTER MVM DIN 315 VINGMUTTER AM-TYP OBEH - FZB



BESTÄLLNINGSEXEMPEL:
13203100 - VM-A M10 FZB
13201100 - MVM M10 FZB
13226100 - ML4M M10 FZB
13221100 - M4M M10 FZB
13171100 - MHM M10 FZB

MVM DIN 315				
C:A PRIS/100 ST				
DIM	NV	Höjd	OBEH	FZB
M4	20	10		X
M5	25	12		X
M6	32	16		X
M8	40	20		X
M10	50	25		X
M12	64	32		X
M14	70	34		X
M16	72	36		X
M20	90	45		X
M24	112	56		

VM-A				
C:A PRIS/100 ST				
DIM	NV	Höjd	OBEH	FZB
M3	20	10		X
M4	20	10		X
M5	22	11		X
M6	27	13		X
M8	30	15		X
M10	36	18		X
M12	48	24		X
M14				
M16				X
M20				
M24				

FÖRP	OBEH	FZB	OBEH	FZB
500 ST		M4-		M3-
200 ST		M6-		M8-
100 ST		M8-		M10-
50 ST		M12-		M16-
20 ST		M16-		

ÖVRIGA DIMENSIONER MOT FÖRFRÅGAN !

SWEBOLT AB

TEL 08-555 975 00 FAX 08-583 581 82

ARTIKELLISTA

2013-2014

SVETSMUTTER 4-K SVM4M DIN 928

SVETSMUTTER 6-K SVM6M DIN 929



SVM4M DIN 928			
C:A PRIS/100 ST			
DIM	NV	Höjd	OBEH
M3			
M4	7	3.5	
M5	9	4.2	X
M6	10	5	X
M8	14	6.5	X
M10	17	8	X
M12	19	9.5	X

SVM6M DIN 929			
C:A PRIS/100 ST			
DIM	NV	Höjd	OBEH
M3	7.5	3	X
M4	9	3.5	X
M5	10	4	X
M6	11	5	X
M8	14	6.5	X
M10	17	8	X
M12	19	10	X
M14	22	11	X
M16	24	13	X

FÖRP.	SAMTLIGA
500 ST	M3-
200 ST	M6-
100 ST	M10-



ISLAGSMUTTER

OBEH - FZB

C:A PRIS/100 ST				
DIM	HÖJD	Flänsdia.	OBEH	FZB
M4	8	15.3		X
M5	8.2	17	X	X
M6	9	19		X
M8	11.3	22		X
M10	12.2	25		X
M12				X

FÖRP.	OBEH	FZB
200 ST		M4-
100 ST		M8-

ÖVRIGA DIMENSIONER MOT FÖRFRÅGAN !

BESTÄLLNINGSEXEMPEL:

13215100 - SVM4M M10 OBEH DIN 928

13216100 - SVM6M M10 OBEH DIN 929

13521100 - ISLAGSMUTTER M10 FZB

SWEBOLT AB

TEL 08-555 975 00 FAX 08-583 581 82

ARTIKELLISTA

2013-2014

SKARVMUTTER SEXKANT FYRKANT

OBEH - FZB - FZV

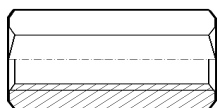

6-KANT SKARVMUTTER M6MH					
C:A PRIS/100 ST					
DIM	NV	Höjd	OBEH	FZB	FZV
M6	10	25		X	
M6	10	40		X	
M8	13	25		X	
M8	13	30		X	
M8	13	50		X	
M10	17	40		X	
M10	17	50	X	X	X
M12	19	50	X	X	X
M16	24	50	X	X	X
M20	30	50	X	X	X
M24	36	50	X	X	X
M30	46	50			X

RUND SKARVMUTTER MRMH					
C:A PRIS/100 ST					
DIM	Y dia.	Höjd	OBEH	FZB	FZV
M6	Ø10	25		X	
M6	Ø10	40		X	
M8	Ø11	25		X	
M8	Ø11	30		X	
M8	Ø11	50		X	
M10	Ø13	40		X	
M10	Ø13	50		X	
M12	Ø15	50		X	
M16		50		X	
M20		50		X	
M24		50		X	

4-KANT SKARVMUTTER M4MH					
C:A PRIS/100 ST					
DIM	4-kant	Höjd	OBEH	FZB	FZV
M6	10	25			
M6	10	40			
M8	13	25			
M8	13	30			
M8	13	50			
M10	16	40			
M10	16	50			
M12	18	50			
M16	24	50			
M20	30	50			
M24	36	50			

FÖRP.	SAMTLIGA
100 ST	M6-
50 ST	M10-
25 ST	M16-
10 ST	M24-

BESTÄLLNINGSEXEMPEL: 13230120 - M6MH M12x50 FZB
 BESTÄLLNINGSEXEMPEL: 1323110040 - M6MH M10x40 FZB
 BESTÄLLNINGSEXEMPEL: 13232160 - M6MH M16x50 FZV

SKARVMUTTER DIN 6334 - 6330B - 6331 8 - 10 OBEH - FZB

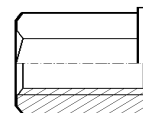
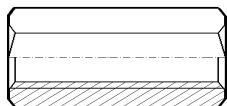

M6MH DIN 6334					
C:A PRIS/100 ST					
DIM	NV	Höjd	8	8 FZB	10
M8	13	24			
M10	17	30			
M12	19	36			
M14	22	42			
M16	24	48			
M18	27	54			
M20	30	60			
M22	32	66			
M24	36	72			
M27	41	81			
M30	46	90			
M33	50	99			
M36	55	108			

M6MH DIN 6330B					
C:A PRIS/100 ST					
DIM	NV	Höjd	8	8 FZB	10
M6	10	9			
M8	13	12			X
M10	17	15			X
M12	19	18			X
M16	24	24			X
M18	27	27			
M20	30	30			X
M22	32	33			X
M24	36	36			X
M27	41	40.5			
M30	46	45			
M33	50	49.5			
M36	55	54			X

M6MHF DIN 6331					
C:A PRIS/100 ST					
DIM	NV	Höjd	8	8 FZB	10
M8	13	12			
M10	17	15			
M12	19	18			X
M14	22	21			X
M16	24	24			X
M18	27	27			X
M20	30	30			X
M22	32	33			
M24	36	36			X
M30	46	45			
M33	50	49.5			
M36	55	54			
M42	65	63			
M48	75	72			

ÖRVIGA DIMENSIONER MOT FÖRFRÅGAN !

FÖRP.	SAMTLIGA
100 ST	M6-
50 ST	M10-
25 ST	M16-
10 ST	M24-

BESTÄLLNINGSEXEMPEL: 1323216024 - M6MH M16x24 DIN 6330B
 BESTÄLLNINGSEXEMPEL: 13234240 - M6MHF M24 -10 DIN 6331

SWEBOLT AB

TEL 08-555 975 00 FAX 08-583 581 82

ARTIKELLISTA

2013-2014
PALMUTTER
PM DIN 7967
OBEH - FZB - FZV



PM DIN 7967					
C:A PRIS/100 ST					
DIM	NV	Höjd	OBEH	FZB	FZV
M8	13	3,5	X	X	X
M10	17	4	X	X	X
M12	19	4,5	X	X	X
M14	22	5	X	X	X
M16	24	5	X	X	X
M20	30	6	X	X	X
M24	36	7	X	X	X
M27	41	7	X	X	X
M30	46	8	X	X	X
M33			X	X	X
M36	55	9	X	X	X
M39			X	X	X

FÖRP	OBEH	FZB	FZV
1000 ST		M6-	
500 ST		M14-	
250 ST		M20-	
100 ST		M24-	

BESTÄLLNINGSEXEMPEL: 13251120 - PM M12 FZB

ÖVRIGA DIMENSIONER MOT FÖRFRÅGAN !

SWEBOLT AB

TEL 08-555 975 00 FAX 08-583 581 82

ARTIKELLISTA

2013-2014

SEXKANTMUTTER U6M OBEH - FZB - FZV

SEXKANTMUTTER FU6M OBEH - FZB

LÅSMUTTER LU6M FZB

LÅSMUTTER FLU6M FZB

LÅG MUTTER UL6M OBEH - FZB



C:A PRIS/100 ST

DIM	NV		U6M/UNC			FU6M/UNF		LU6M UNC	FLU6M UNF	UL6M/UNC	
	(mm)	(tum)	OBEH	FZB	FZV	OBEH	FZB	FZB	FZB	OBEH	FZB
Nr4-40				X							
3/16"	9.5	3/8		X							
1/4"	11.1	7/16		X			X	X	X		X
5/16"	12.7	1/2		X			X	X	X		
3/8"	14.3	9/16	X	X	X		X	X	X		
7/16"	17.5			X			X	X	X		
1/2"	19	3/4	X	X	X		X	X	X		
9/16"	22.2	7/8		X			X	X	X		
5/8"	23.8	15/16	X	X	X		X	X	X		
3/4"	28.6	1 1/8	X	X	X		X	X	X		
7/8"	33.3	1 5/16	X	X	X		X	X	X		X
1"	38.1	1 1/2	X	X	X		X	X	X		
1 1/8"	42.9	1 1/16									
1 1/4"	47.6	1 7/8	X		X			X	X		
1 3/8"	52.4	2 1/16									
1 1/2"	57.2	2 1/4	X		X			X	X		X
1 3/4"	66.7	2 5/8	X								
2"	76.2	3	X		X			X			
2 1/4"	85.7	3 3/8									
2 1/2"	95.2	3 3/4									
2 3/4"	104.8	4 1/8									
3"	114.3	4 1/2									

ÖVRIGA DIMENSIONER MOT FÖRFRÅGAN !

FÖRP.	OBEH	FZB	FZV	OBEH	FZB	FZB	FZB	OBEH	FZB
200 ST		3/16"-		3/16"-	1/4"-	1/4"-	1/4"-		1/4"
100 ST	3/8"-	3/8"-		3/8"-	3/8"-	3/8"-	3/8"-		
50 ST	5/8"-	5/8"-		5/8"-	5/8"-	5/8"-	5/8"-		5/8"
25 ST	1 1/4"-	1"-			7/8"-	1"-	1"-		
5 ST									1 1/2"

BESTÄLLNINGSEXEMPEL:

13051127 - U6M 1/2"UNC FZB

13052127 - U6M 1/2"UNC FZV

13056127 - FU6M 1/2"UNF FZB

13105127 - LU6M 1/2"UNC FZB

SWEBOLT AB

TEL 08 - 555 975 00 FAX 08 - 583 581 82

ARTIKELLISTA

2013-2014

SEXKANTMUTTER M6M DIN 934 LÅSMUTTER LM6M DIN 985 LÅG MUTTER ML6M DIN 439B ROSTFRI A2 - SYRAFAST A4

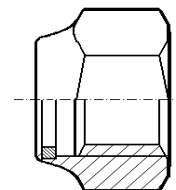
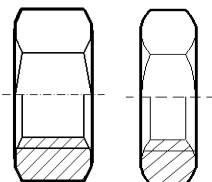

DIM	M6M DIN 934				LM6M DIN 985				ML6M DIN 439B			
	NV	Höjd	A2	A4-80	NV	Höjd	A2	A4-80	NV	Höjd	A2	A4
	C:A PRIS/100 ST											
M2	4	1.6	X	X								
M2.5	4.5	1.8	X	X								
M3	5.5	2.4	X	X	5.5	4	X	X	5.5	1.8	X	X
M4	7	3.2	X	X	7	5	X	X	7	2.2	X	X
M5	8	4	X	X	8	5	X	X	8	2.7	X	X
M6	10	5	X	X	10	6	X	X	10	3.2	X	X
M8	13	6.5	X	X	13	8	X	X	13	4	X	X
M10	17	8	X	X	17	10	X	X	17	5	X	X
M12	19	10	X	X	19	12	X	X	19	6	X	X
M14	22	11	X	X	22	14	X	X	22	7	X	X
M16	24	13	X	X	24	16	X	X	24	9	X	X
M18	27	15	X	X	27	18.5	X	X	27	9	X	X
M20	30	16	X	X	30	20	X	X	30	10	X	X
M22	32	18	X	X	32	22	X	X	34	11	X	X
M24	36	19	X	X	36	24	X	X	36	12	X	X
M27	41	22	X	X	41	27	X	X	41	13.5	X	X
M30	46	24	X	X	46	30	X	X	46	15	X	X
M33	50	26	X	X	50	33	X	X	50	16.5		
M36	55	29	X	X	55	36	X	X	55	18		X
M39	60	31	X	X								
M42	65	34	X	X				X	65	21		
M48	75	38	X	X					75	24		

KRYSSMARKERADE ARTIKLAR MOT FÖRFRÅGAN !

FÖRP.	A2	A4-80
200 ST	M3-	M3-
100 ST	M10-	M6-
50 ST	M12-	M12-
25 ST	M20-	M20-
10 ST	M27-	M27-
1 ST	M42-	M42-

DIN 934 A2+FZB / A4+FZB

DIM	NV	Höjd	A2FZB	A4FZB
M6	10	5	X	X
M8	13	6.5	X	X
M10	17	8	X	X
M12	19	10	X	X
M16	24	13	X	X
M20	30	16	X	X

ISO 4032 A2 / A4

DIM	NV	Höjd	A2	A4
M8	13	6.8	X	X
M10	16	8.4	X	X
M12	18	10.8	X	X
M16	27	14.8	X	X
M20	30	18	X	X

BESTÄLLNINGSEXEMPEL

23010080 - M6M M8 A2
23011080 - M6M M8 A4-80
23100120 - LM6M M12 A2
23101120 - LM6M M12 A4-80

DIN 985 A2+FZB / A4+FZB

DIM	NV	Höjd	A2FZB	A4FZB
M6	10	6	X	X
M8	13	8	X	X
M10	17	10	X	X
M12	19	12	X	X
M16	24	16	X	X
M20	27	18.5	X	X

SWEBOLT AB

TEL 08 - 555 975 00 FAX 08 - 583 581 82

ARTIKELLISTA

2013-2014

HATTMUTTER MHM DIN 1587 SVETSMUTTER 6-KANT DIN 929 ROSTFRI A2 - SYRAFAST A4

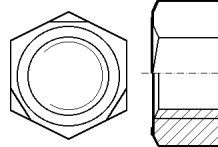
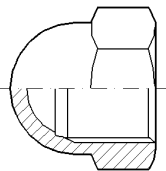

MHM DIN 1587					SVM6M DIN 929			
C:A PRIS/100 ST					C:A PRIS/100 ST			
DIM	NV	Höjd	A2	A4	NV	Höjd	A2	A4
M3	5.5	5	X	X	7.5	3		X
M4	7	8	X	X	9	3.5	X	X
M5	8	10	X	X	10	4	X	X
M6	10	12	X	X	11	5	X	X
M8	13	15	X	X	14	6.5	X	X
M10	16/17	18	X	X	17	8	X	X
M12	18/19	22	X	X	19	10		X
M14	21/22	25		X				
M16	24	28	X	X	24	13		
M20	30	34		X				
M24	36	42		X				
M27	41	45						
M30	46	50						

FÖRP	A2	A4	A2	A4
200 ST			M4-	M3-
100 ST	M3-	M3-	M8-	M8-
50 ST	M12-	M12-		
25 ST	M16-	M16-		
10 ST	M20-	M20-		

VINGMUTTER AMERIKANSK TYP A2 - A4

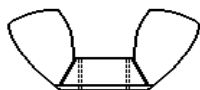

VM-A				
C:A PRIS/100 ST				
DIM	NV	Höjd	A2	A4
M3	18	8.8	X	X
M4	18.5	8.8	X	X
M5	22	10.5	X	X
M6	27	12.9	X	X
M8	30	14.8	X	X
M10	36	17.3	X	X
M12	47.5	27.5	X	X
M16	65	30.8	X	X
M20	66.5	31.2	X	X

KRYSSMARKERADE ARTIKLAR MOT FÖRFRÅGAN !
ÖVRIGA DIMENSIONER MOT FÖRFRÅGAN !

FÖRP.	A2	A4
100 ST	M3-	M3-
50 ST	M10-	M10-
25 ST	M16-	M16-

BESTÄLLNINGSEXEMPEL:

23170100 - MHM M10 A2 23200100 - VM-A M10 A2
 23171100 - MHM M10 A4 23201100 - VM-A M10 A4
 23216100 - SVM6M M10 A2 23121100 - HLM6M M10 A4
 23217100 - SVM6M M10 A4

SWEBOLT AB

TEL 08-555 975 00 FAX 08-583 581 82

ARTIKELLISTA

2013-2014

HELMETALLISK LÅSMUTTER DIN 980 ROSTFRI A2 - SYRAFAST A4

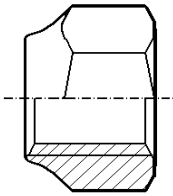

HLM6M DIN 980				
C:A PRIS/100 ST				
DIM	NV	Höjd	A2	A4
M3	5.5	3.7		
M4	7	4.2	X	X
M5	8	5.1	X	X
M6	10	6	X	X
M8	13	8	X	X
M10	17	10	X	X
M12	19	12	X	X
M14	22	14		
M16	24	16	X	X
M18	27	18		
M20	30	20	X	X
M24	36	24		

FORP	A2	A4
200 ST	M3-	M3-
100 ST	M12-	M12-
50 ST	M14-	M14-
10 ST	M24-	M24-

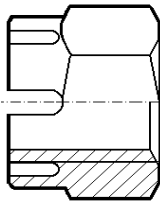

KRONMUTTER DIN 935

MKM DIN 935				
C:A PRIS/100 ST				
DIM	NV	Höjd	A2	A4
M5	8	6,0		
M6	10	7.5	X	X
M8	13	9.5	X	X
M10	16	12	X	X
M12	18	15	X	X
M14	21	16	X	X
M16	24	19	X	X
M18	27	21	X	X
M20	30	22	X	X
M22	34	26		
M24	36	27	X	X
M27	41	30	X	X
M30	46	33	X	X

FORP	A2	A4
200 ST	M3-	M3-
100 ST	M12-	M12-
50 ST	M14-	M14-
10 ST	M24-	M24-

BESTALLNINGSEXEMPEL: 23120100 - HLM6M M10 A2
BESTALLNINGSEXEMPEL: 23121120 - HLM6M M12 A4
BESTALLNINGSEXEMPEL: 23130160 - MKM M16 A2
BESTALLNINGSEXEMPEL: 23131200 - MKM M20 A4

SWEBOLT AB

TEL 08 - 555 975 00 FAX 08 - 583 581 82

ARTIKELLISTA

2013-2014

FINGÄNGAD SEXKANTMUTTER DIN 934 LÅG FINGÄNGAD SEXKANTMUTTER DIN 439B ROSTFRI A2 - SYRAFAST A4

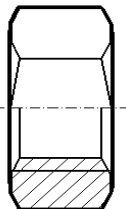

FM6M DIN 934					FML6M DIN 439B	
C:A PRIS/100 ST					C:A PRIS/100 ST	
DIM	NV	Höjd	A2	A4	A2	A4
M6x0.75	10	2.09			X	
M8x0.5	13	6.5				
M8x1	13	6.5	X	X		
M10x1	17	8	X	X		
M10x1.25	17	8	X	X		X
M12x1	19	10	X	X		
M12x1.25	19	10	X	X		X
M12x1.5	19	10	X	X		X
M14x1.5	22	11	X	X		X
M16x1.5	24	13	X	X		X
M18x1.5	27	15	X	X		X
M20x1.5	30	16	X	X		X
M20x2	30	16	X	X		
M22x1.5	32	18	X	X		
M24x1.5	36	19	X	X		
M24x2	36	19	X	X		
M27x1.5	41	22	X	X		
M27x2	41	22	X	X		
M30x1.5	46	24	X	X		
M30x2	46	24	X	X		
M36x1.5	55	29	X	X		
M39x1.5	60	31	X	X		

FÖRP	A2	A4	A2	A4
200 ST	M8-	M8-		M8-
100 ST	M12-	M12-		M12-
50 ST	M18-	M18-		M18-
25 ST	M22-	M22-		M22-
10 ST	M36-	M36-		M36-

BESTÄLLNINGSEXEMPEL: 230301010 - FM6M M10x1 A2

BESTÄLLNINGSEXEMPEL: 230312420 - FM6M M24x2 A4

BESTÄLLNINGSEXEMPEL: 230861615 - FML6M M16x1,5 A4

SWEBOLT AB

TEL 08-555 975 00 FAX 08-583 581 82

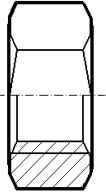

ARTIKELLISTA

2013-2014

SEKKANTMUTTER U6M A2 - A4

U6M-UNC ANSI B18.2				
DIM	NV	Höjd	A2	A4
1/4"	11.1	5.6		X
5/16"	12.7	6.7		X
3/8"	14.3	8.3		X
7/16"	17.5	9.5		
1/2"	19	11.1		X
5/8"	23.8	13.9		X
3/4"	28.6	16.3		X
7/8"	33.3	19.1		X
1"	38.1	21.8		X

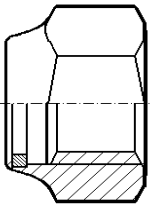

NYLONLÅSMUTTER LU6M A2 - A4

LU6M-UNC ~DIN 985				
DIM	NV	Höjd	A2	A4
1/4"	11	6		X
5/16"	13	7		X
3/8"	14	8		X
7/16"	17	10		X
1/2"	19	11		X
5/8"	24	16		X
3/4"	27	18		X
7/8"	32	22		X
1"	36	24		X

FÖRP.	A2	A4
100 ST		1/4 - 5/16
50 ST		3/8 - 5/8
25 ST		3/4 - 7/8
10 ST		1"

BESTÄLLNINGSEXEMPEL: 23051190 - U6M 3/4 UNC A4

BESTÄLLNINGSEXEMPEL: 23051190 - U6M 3/4 UNC A4

SWEBOLT AB

TEL 08 - 555 975 00 FAX 08 - 583 581 82

ARTIKELLISTA

2013-2014

FLÄNSMUTTER DIN 6923 ROSTFRI A2 - SYRAFAST A4

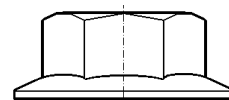

M6MF DIN 6923					
C:A PRIS/100 ST					
DIM	NV	DIAM	Höjd	A2	A4
M4	7	10.2	5		X
M5	8	11.8	5		X
M6	10	14.2	6		X
M8	13	17.9	8		X
M10	15	21.8	10		X
M12	18	26	12		X

FÖRP	A2	A4
200 ST	M5-	M5-
100 ST	M6-	M6-

TANDAD FLÄNSMUTTER ~DIN 6923

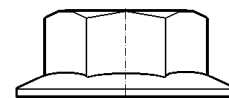

M6MFT ~DIN 6923					
C:A PRIS/100 ST					
DIM	NV	DIAM	Höjd	A2	A4
M4	7	10.2	5		X
M5	8	11.8	5		X
M6	10	14.2	6		X
M8	13	17.9	8	X	X
M10	15	21.8	10	X	X
M12	18	26	12		X

FÖRP	A2	A4
200 ST	M3-	M3-
100 ST	M12-	M12-
50 ST	M14-	M14-
10 ST	M24-	M24-

BESTÄLLNINGSEXEMPEL: 23240100 - M6MF M10 A2

BESTÄLLNINGSEXEMPEL: 23241120 - M6MF M12 A4

BESTÄLLNINGSEXEMPEL: 23295080 - M6MFT M8 A2

BESTÄLLNINGSEXEMPEL: 23296100 - M6MFT M10 A4

SWEBOLT AB

TEL 08 - 555 975 00 FAX 08 - 583 581 82

ARTIKELLISTA

2013-2014

SEXKANTMUTTER M6M MÄSSING DIN 934 HATTMUTTER MHM MÄSSING DIN 1587

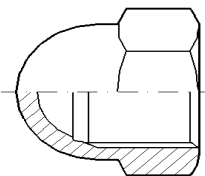
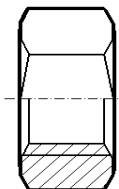

M6M DIN 934					MHM DIN 1587			
C:A PRIS/100 ST					C:A PRIS/100 ST			
DIM	NV	Höjd	OBEH	FÖRN	NV	Höjd	OBEH	FÖRN
M2	4	1.6	X					
M3	5.5	2.4	X	X	5.5	6	X	
M4	7	3.2	X	X	7	8	X	X
M5	8	4	X	X	8	10	X	X
M6	10	5	X	X	10	12	X	X
M8	13	6.5	X	X	13	15	X	X
M10	17	8	X	X	16/17	18	X	X
M12	19	10	X	X	18/19	22	X	X
M14	22	11			21/22	25		
M16	24	13	X	X	24	28	X	X
M20	30	16	X	X	30	34	X	X
M24	36	19	X		36	42		

FÖRP.	OBEH	FÖRN	OBEH	FÖRN
200 ST	M3-	M3-	M3-	M3-
100 ST	M10-	M10-	M8-	M8-
50 ST	M16-	M16-	M12-	M12-

VINGMUTTER MVM DIN 315 MÄSSING

MVM DIN 315				
C:A PRIS/100 ST				
DIM	NV	Höjd	OBEH	FÖRN
M4	20	10	X	X
M5	25	12	X	X
M6	32	16	X	X
M8	40	20	X	X
M10	50	25	X	X
M12	64	32	X	X
M16	72	36	X	

FÖRP	OBEH	FÖRN
100 ST	M3-	
50 ST	M12-	

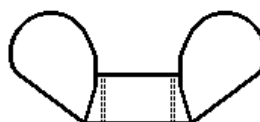

ÖVRIGA DIMENSIONER MOT FÖRFRÅGAN !

BESTÄLLNINGSEXEMPEL:

33010080 - M6M M8 MÄSSING

33011080 - M6M M8 MÄSSING FÖRNICKLAD













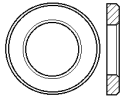
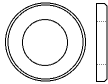
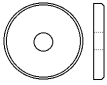

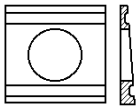
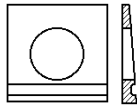
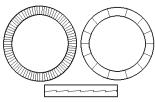
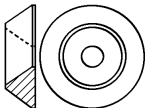
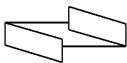







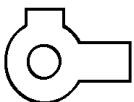

33170160 - MHM M16 MÄSSING

33171160 - MHM M16 MÄSSING FÖRNICKLAD

33200100 - MVM M10 MÄSSING

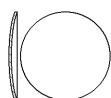

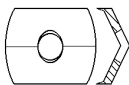
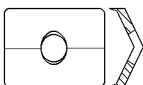

SWEBOLT AB

TEL 08 - 555 975 00 FAX 08 - 583 581 82

- 1 - 	- 2 - 	- 3 - 	- 4 - 
- 5 - 	- 6 - 	- 7 - 	- 8 - 
- 9 - 	- 10 - 	- 11 - 	- 12 - 
- 13 - 	- 14 - 	- 15 - 	- 16 - 
- 17 - 	- 18 - 	- 19 - 	- 20 - 
- 21 - 	- 22 - 	- 23 - 	- 24 - 
- 25 - 	- 26 - 	- 27 - 	- 28 - 
- 29 - 	- 30 - 	- 31 - 	- 32 - 

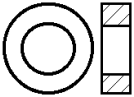
SWEBOLT AB

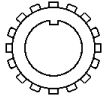
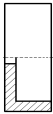
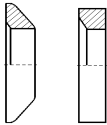
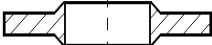
TEL. 08-584 909 60 FAX. 08-583 581 82

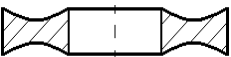
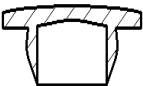
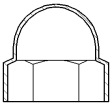
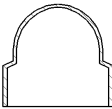
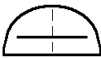
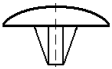
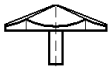
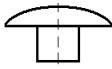
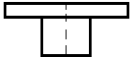
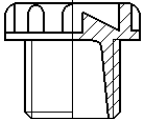
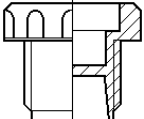
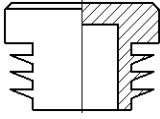
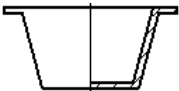
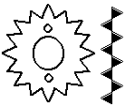
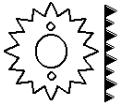
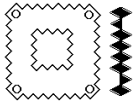
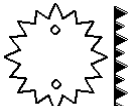
- 33 - 	- 34 - 	- 35 - 	- 36 - 
- 37 - 	- 38 - 	- 39 - 	- 40 - 
- 41 - 	- 42 - 	- 43 - 	- 44 - 
- 45 - 	- 46 - 	- 47 - 	- 48 - 
- 49 - 	- 50 - 	- 51 - 	- 52 - 
- 53 - 	- 54 -	- 55 -	- 56 -
- 57 - 	- 58 - 	- 59 - 	- 60 - 
- 61 -	- 62 -	- 63 -	- 64 -

SWEBOLT AB

TEL. 08-584 909 60 FAX. 08-583 581 82

PRODUKTER I STÅL

1	14000	BRB, PLANBRICKA			HB200	OBEH	4:1
1	14001	BRB, PLANBRICKA			HB200	FZB	4:1
1	14002	BRB, PLANBRICKA			HB200	FZV	4:1
1	14003	RB, PLANBRICKA	125A	7089	HV200	OBEH	4:1
1	14004	RB, PLANBRICKA	125A	7089	HV200	FZB	4:1
1	14005	RB, PLANBRICKA	125A	7089	HV200	FZV	4:1
1	14006	RB, PLANBRICKA	125		HV140	OBEH	4:1
1	14007	RB, PLANBRICKA	125		HV140	FZB	4:1
1	14008	RB, PLANBRICKA	125		HV140	FZV	4:1
1	14009	HRB, PLANBRICKA	125A	7089	HV300	OBEH	4:1
1	14010	HRB, PLANBRICKA	125A	7089	HV300	FZB	4:1
1	14011	BRFB, RUND FASAD BRICKA			HB200	OBEH	4:2
1	14012	BRFB, RUND FASAD BRICKA			HB200	FZB	4:2
1	14013	BRFB, RUND FASAD BRICKA			HB200	FZV	4:2
1	14016	SRB, PLANBRICKA, SMS 71				OBEH	4:4
1	14017	SRB, PLANBRICKA, SMS 71				FZB	4:4
1	14018	SRB, PLANBRICKA, SMS 71				FZV	4:4
1	14019	BRB, PLANBRICKA		7089	HB200	SVOX	4:1
2	14070	RBS, STOR PLANBRICKA	9021	7093		OBEH	4:3
2	14071	RBS, STOR PLANBRICKA	9021	7093		FZB	4:3
2	14069	RBS, STOR PLANBRICKA	9021	7093		FZV	4:3
2	14030	NB, NITBRICKA				OBEH	4:4
2	14031	NB, NITBRICKA				FZB	4:4
1	14032	SRB, PLANBRICKA	126	7091	HV140	OBEH	4:2
1	14033	SRB, PLANBRICKA	126	7091	HV140	FZB	4:2
1	14034	SRB, PLANBRICKA	126	7091	HV140	FZV	4:2
2	14035	SRKB, KAROSSERIBRICKA				OBEH	4:4
2	14036	SRKB, KAROSSERIBRICKA				FZB	4:4
2	14245	HRB, HÄRDAD BRICKA	6340			OBEH	4:21
2	14046	HRB, HÄRDAD BRICKA	6340			FZB	4:21
2	14050	PB, PLANBRICKA	433	7092	HV250	OBEH	4:9
2	14051	PB, PLANBRICKA	433	7092	HV250	FZB	4:9
2	14054	PB-FRP, PLANBRICKA FÖR FRP	7349			FZB	4:21
2	14055	PBM, PLANBRICKA MEDEL	1440			OBEH	4:12
2	14056	PBM, PLANBRICKA MEDEL	1440			FZB	4:12
2	14058	PBG, PLANBRICKA GROV	1441			OBEH	4:12
2	14059	PBG, PLANBRICKA GROV	1441			FZB	4:12
3	14072	SBB, STÅLBYGGNADSBRICKA	6916	7416	C45	OBEH	4:3
3	14073	SBB, STÅLBYGGNADSBRICKA	6916	7416	C45	FZB	4:3
3	14074	SBB, STÅLBYGGNADSBRICKA	6916	7416	C45	FZV	4:3
34	14075	SBRB, STÅLBYGGN.BRICKA HÖG				FZV	4:3
34	14076	SBRB, STÅLBYGGNADSBRICKA	7989			OBEH	4:3
34	14077	SBRB, STÅLBYGGNADSBRICKA	7989			FZB	4:3
34	14078	SBRB, STÅLBYGGNADSBRICKA	7989			FZV	4:3

SWEBOLT AB

TEL. 08-584 909 60 FAX. 08-583 581 82

BILD	ART.GR.	BENÄMNING	DIN	ISO	KVAL	YTBEH	SIDA
4	14020	TBRB, TJOCK FASAD BRICKA				OBEH	4:7
4	14021	TBRB, TJOCK FASAD BRICKA				FZB	4:7
4	14022	TBRB, TJOCK FASAD BRICKA				FZV	4:7
5	14025	TBR SB, TJOCK FASAD STOR BRICKA				OBEH	4:7
5	14026	TBR SB, TJOCK FASAD STOR BRICKA				FZB	4:7
5	14027	TBR SB, TJOCK FASAD STOR BRICKA				FZV	4:7
6	14100	S4B, FYRKANTBRICKA	436			OBEH	4:8
6	14101	S4B, FYRKANTBRICKA	436			FZB	4:8
6	14102	S4B, FYRKANTBRICKA	436			FZV	4:8
6	14103	S4B, FYRKANTBRICKA	436		HV200	FZB	4:8
6	14104	S4B, FYRKANTBRICKA	436		HV200	FZV	4:8
6	14110	4BB, STOR FYRKANTBRICKA				OBEH	4:8
6	14111	4BB, STOR FYRKANTBRICKA				FZB	4:8
6	14112	4BB, STOR FYRKANTBRICKA				FZV	4:8
7	14115	UBB, U-BALKSBRICKA, 8%	434			OBEH	4:11
7	14116	UBB, U-BALKSBRICKA, 8%	434			FZB	4:11
7	14117	UBB, U-BALKSBRICKA, 8%	434			FZV	4:11
7	14120	UB14, U-BALKSBRICKA, 14%	435			OBEH	4:11
7	14121	UB14, U-BALKSBRICKA, 14%	435			FZB	4:11
7	14122	UB14, U-BALKSBRICKA, 14 %	435			FZV	4:11
8	14118	IB, I-BALKSBRICKA, 14%	6917			OBEH	4:11
8	14119	IB, I-BALKSBRICKA, 14%	6917			FZV	4:11
8	14123	IB, I-BALKSBRICKA, 8%	6918			OBEH	4:11
8	14124	IB, I-BALKSBRICKA, 8%	6918			FZV	4:11
9	14130	NL, SMÅ OLIMMADE (UTGÅR)	NORDLOCK			OBEH	
9	14131	NL, SMÅ LIMMADE	NORDLOCK			FZG	4:10
9	14132	NL, STORA OLIMMADE (UTGÅR)	NORDLOCK			OBEH	
9	14133	NL, STORA LIMMADE	NORDLOCK			FZG	4:10
10	14135	FB, FÖRSÄNK T BRICKA 90°, 110°				OBEH	4:12
10	14136	FB, FÖRSÄNK T BRICKA 90°, 110°				FZB	4:12
11	14140	FBB, FJÄDERBRICKA	127B			OBEH	4:5
11	14141	FBB, FJÄDERBRICKA	127B			FZB	4:5
11	14142	FBB, FJÄDERBRICKA	127B			FZV	4:5
11	14143	FBR, FJÄDERBRICKA f. INSEX	7980			OBEH	4:10
11	14144	FBR, FJÄDERBRICKA f. INSEX	7980			FZB	4:10
12	14145	FBH, FJÄDERBRICKA	128A			OBEH	4:5
12	14146	FBH, FJÄDERBRICKA	128A			FZB	4:5
13	14150	KBA, KUPAD BRICKA	137A			OBEH	4:6
13	14151	KBA, KUPAD BRICKA	137A			FZB	4:6
14	14155	KBB, KUPAD BRICKA	137B			OBEH	4:6
14	14156	KBB, KUPAD BRICKA	137B			FZB	4:6
15	14160	LB-AT, LÅSBRICKA GROVT. AT.	6797A			OBEH	4:13
15	14161	LB-AT, LÅSBRICKA GROVT. AT.	6797A			FZB	4:13

SWEBOLT AB

TEL. 08-584 909 60 FAX. 08-583 581 82

BILD	ART.GR.	BENÄMNING	DIN	ISO	KVAL	YTBEH	SIDA
16	14162	LB-IT, LÅSBRICKA GROVT. IT.	6797I			OBEH	4:13
16	14163	LB-IT, LÅSBRICKA GROVT. IT.	6797I			FZB	4:13
17	14170	LB-AZ, LÅSBRICKA FINT. AZ	6798A			OBEH	4:6
17	14171	LB-AZ, LÅSBRICKA FINT. AZ	6798A			FZB	4:6
18	14172	LB-IZ, LÅSBRICKA FINT. IZ	6798J			OBEH	4:6
18	14173	LB-IZ, LÅSBRICKA FINT. IZ	6798J			FZB	4:6
19	14174	LB-IZV, FÖRSÄNKT LÅSBRICKA	6798V			OBEH	4:13
19	14175	LB-IZV, FÖRSÄNKT LÅSBRICKA	6798V			FZB	4:13
20	14180	RRB, RÄFFLAD BRICKA schnorr				OBEH	4:10
20	14181	RRB, RÄFFLAD BRICKA schnorr				FZB	4:10
21	14185	LB4, REKTANGULÄRT LÅSBLECK				OBEH	4:14
21	14186	LB4, REKTANGULÄRT LÅSBLECK				FZB	4:14
22	14190	LB1, LÅSBLECK m. 1 LÄPP	93			OBEH	4:14
22	14191	LB1, LÅSBLECK m. 1 LÄPP	93			FZB	4:14
23	14195	LB2, LÅSBLECK m. 2 LÄPPAR	463			OBEH	4:14
23	14196	LB2, LÅSBLECK m. 2 LÄPPAR	463			FZB	4:14
24	14200	LBUL, LÅSBLECK UTV. LÄPP	432			OBEH	4:14
24	14201	LBUL, LÅSBLECK UTV. LÄPP	432			FZB	4:14
25	14205	LBIL, LÅSBLECK INV. LÄPP	462			OBEH	4:15
25	14206	LBIL, LÅSBLECK INV. LÄPP	462			FZB	4:15
26	14210	LBFL, FLERLÄPPS LÅSBLECK	70952A			OBEH	4:15
26	14211	LBFL, FLERLÄPPS LÅSBLECK	70952A			FZB	4:15
27	14215	RFB, FÖRSLUTNINGSBR. RAK	443	A		OBEH	4:16
27	14216	RFB, FÖRSLUTNINGSBR. RAK	443	B		OBEH	4:16
27	14220	KFB, FÖRSLUTNINGSBR. KONISK	443	A		OBEH	4:16
27	14221	KFB, FÖRSLUTNINGSBR. KONISK	443	B		OBEH	4:16
28	14225	EB, ENDBRICKA	470			OBEH	4:17
28	14226	EB, ENDBRICKA	470			FZB	4:17
29	14230	FR, FJÄDERRING KONISK	74361C			OBEH	4:9
29	14231	FR, FJÄDERRING KONISK	74361C			FZB	4:9
30	14235	ABA, ANSLUTNINGBRICKA	46288A			OBEH	4:9
30	14236	ABA, ANSLUTNINGBRICKA	46288A			FZB	4:9
31	14240	ABB, ANSLUTNINGBRICKA	46288B			OBEH	4:9
31	14241	ABB, ANSLUTNINGBRICKA	46288B			FZB	4:9
32	14245	BUH, BRICKA UTAN HÅL				OBEH	4:17
32	14246	BUH, BRICKA UTAN HÅL				FZB	4:17
2	14250	TRB, FÖR TRÄKONSTR.	440R			OBEH	4:17

SWEBOLT AB

TEL. 08-584 909 60 FAX. 08-583 581 82

BILD	ART.GR.	BENÄMNING	DIN	ISO	KVAL	YTBEH	SIDA
2	14251	TRB, FÖR TRÄKONSTR.	440R			FZB	4:17
33	14253	RB4, BRICKA m. 4-KANTHÅL	440V			OBEH	4:17
33	14254	RB4, BRICKA m. 4-KANTHÅL	440V			FZB	4:17
35	14125	DIB, DUBBELSIDIG TANDBRICKA				OBEH	4:18
35	14126	DIB, DUBBELSIDIG TANDBRICKA				FZB	4:18
38	14233	SFÄRISK BRICKA	6319C			OBEH	4:18
38	14234	SFÄRISK BRICKA	6319D			OBEH	4:18
36	14300	MB, LÅSBRICKA FÖR KULLAGER				OBEH	4:19
36	14301	MB, LÅSBRICKA FÖR KULLAGER				FZB	4:19
57	14402	BULLDOGBRICKA, DUBBEL				FZV	4:20
58	14407	BULLDOGBRICKA, ENKEL				FZV	4:20
59	14412	BULLDOGBRICKA, FYRKANT				FZV	4:20
60	14415	"KILLIBRODD", BULLDOGBRICKA, RUND				OBEH	4:20

ROSTFRITT / SYRAFAST

1	24000	BRB, PLANBRICKA	125	7089	A2		4:40
1	24001	BRB, PLANBRICKA	125	7089	A4		4:40
1	24260	PBT, PASSBRICKA	7349		A2		4:44
1	24261	PBT, PASSBRICKA	7349		A4		4:44
2	24053	PB-FRP, PLANBRICKA FÖR FRP	433	7092	A2		4:44
2	24054	PB-FRP, PLANBRICKA FÖR FRP	433	7092	A4		4:44
2	24070	RBS, STOR PLANBRICKA	9021		A2		4:40
2	24071	RBS, STOR PLANBRICKA	9021		A4		4:40
4	24020	TBRB, TJOCK FASAD BRICKA			A2		4:45
4	24021	TBRB, TJOCK FASAD BRICKA			A4		4:45
5	24025	TBRB, TJOCK FASAD STOR BRICKA			A2		4:45
5	24026	TBRB, TJOCK FASAD STOR BRICKA			A4		4:45
6	24100	S4B, FYRKANTBRICKA	436		A2		4:46
6	24101	S4B, FYRKANTBRICKA	436		A4		4:46
7	24115	UBB, U-BALKSBRICKA, 8%	434		A2		4:47
7	24116	UBB, U-BALKSBRICKA, 8%	434		A4		4:47
7	24120	UB14, U-BALKSBRICKA, 14%	435		A2		4:47
7	24121	UB14, U-BALKSBRICKA, 14%	435		A4		4:47
9	24131	NL, NORDLOCKBRICKA, LIMMAD			A4		4:43
10	24135	FB, FÖRSÄNKT BRICKA 90°, 110°			A2		4:46
10	24136	FB, FÖRSÄNKT BRICKA 90°, 110°			A4		4:46
10	24138	FB, FÖRSÄNKT BRICKA, ROSETT			A2		4:46
11	24140	FBB, FJÄDERBRICKA	127B		A2		4:41
11	24141	FBB, FJÄDERBRICKA	127B		A4		4:41

SWEBOLT AB

TEL. 08-584 909 60 FAX. 08-583 581 82

BILD	ART.GR.	BENÄMNING	DIN	ISO	KVAL	YTBEH	SIDA
11	24143	FBR, FJÄDERBRICKA	7980		A2		4:43
11	24144	FBR, FJÄDERBRICKA	7980		A4		4:43
12	24145	FBH, FJÄDERBRICKA	128A		A2		4:48
12	24146	FBH, FJÄDERBRICKA	128A		A4		4:48
13	24150	KBA, KUPAD BRICKA	137A		A2		4:41
13	24151	KBA, KUPAD BRICKA	137A		A4		4:41
14	24155	KBB, KUPAD BRICKA	137B		A2		4:48
14	24156	KBB, KUPAD BRICKA	137B		A4		4:48
15	24160	LB-AT, LÅSBRICKA, GROVT. AT.	6797A		A2		4:49
15	24161	LB-AT, LÅSBRICKA, GROVT. AT.	6797A		A4		4:49
16	24162	LB-IT, LÅSBRICKA	6797I		A2		4:49
16	24163	LB-IT, LÅSBRICKA	6797I		A4		4:49
17	24170	LB-AZ, LÅSBRICKA	6798A		A2		4:41
17	24171	LB-AZ, LÅSBRICKA	6798A		A4		4:41
18	24172	LB-IZ, LÅSBRICKA	6798J		A2		4:41
18	24173	LB-IZ, LÅSBRICKA	6798J		A4		4:41
19	24174	LB-IZV, FÖRSÄNKT LÅSBRICKA	6798V		A2		4:49
19	24175	LB-IZV, FÖRSÄNKT LÅSBRICKA	6798V		A4		4:49
20	24180	RRB, RÄFFLAD BRICKA schnorr			A2		4:44
22	24190	LB1, LÅSBLECK m. 1 LÄPP	93		A2		4:42
22	24191	LB1, LÅSBLECK m. 1 LÄPP	93		A4		4:42
23	24196	LB2, LÅSBRICKA 2-LÄPP	463		A4		4:42
24	24200	LBUL, LÅSBLECK UTV. LÄPP	432		A2		4:42
24	24201	LBUL, LÅSBLECK UTV. LÄPP	432		A4		4:42
27	24215	RFB, FÖRSLUTNINGSBRICKA RAK443A			A2		4:50
27	24216	KFB, FÖRSLUTNINGSBRICKA RAK443B			A2		4:50
32	24245	BUH, BRICKA UTAN HÅL			A2		4:50
1	24028	RB, PLANBRICKA	125		DUPLEX		

MÄSSING

1	34000	RB, PLANBRICKA	125A+B	7089/7090			4:60
1	34001	RB, PLANBRICKA	125A+B	7089/7090		FÖRNICKLAD	4:60
1	34300	TB, TUNN BRICKA				FÖRNICKLAD	4:61
1	34310	RB, RINGBRICKA				FÖRNICKLAD	4:61
2	34050	PB, PLANBRICKA	433	7092			4:61
2	34051	PB, PLANBRICKA	433	7092		FÖRNICKLAD	4:61
2	34070	RBS, STOR PLANBRICKA	9021	7093			4:60
2	34071	RBS, STOR PLANBRICKA	9021	7093		FÖRNICKLAD	4:60

SWEBOLT AB

TEL. 08-584 909 60 FAX. 08-583 581 82

<u>BILD</u>	<u>ART.GR.</u>	<u>BENÄMNING</u>	<u>DIN</u>	<u>ISO</u>	<u>KVAL</u>	<u>YTBEH</u>	<u>SIDA</u>
10	34138	FB, CUVETTBRICKA (ROSETTBR)				FÖRNICKLAD	4:61

SWEBOLT AB

TEL. 08-584 909 60 FAX. 08-583 581 82

POLYAMID

1	44000	PB, PLANBRICKA	125	7089			4:90
1	44050	PB, PLANBRICKA	433				4:91
2	44070	RBS, STOR PLANBRICKA	9021	7093			4:90
10	44135	FB, FÖRSÄNKT BRICKA 90°, 110°				SVART	4:93
10	44136	FB, FÖRSÄNKT BRICKA 90°, 110°				NATUR	4:93
10	44137	FB, FÖRSÄNKT BRICKA 90°, 110°				VIT	4:93
10	44138	FB, FÖRSÄNKT BRICKA 90°, 110°				GRÖN	4:93
10	44139	FB, FÖRSÄNKT BRICKA 90°, 110°				RÖD	4:93
37	44410	TB, TÄTNINGSBRICKA				SVART	4:95
39	44400	TB, TÄTNINGSBRICKA				SVART	4:95
39	44401	TB, TÄTNINGSBRICKA				NATUR	4:95
39	44402	TB, TÄTNINGSBRICKA				RÖD	4:95
39	44403	TB, TÄTNINGSBRICKA				GRÖN	4:95
40	44450	TBRP, TÄTNINGSBRICKA RÖRPROPP				SVART	4:96
40	44451	TBRP, TÄTNINGSBRICKA RÖRPROPP				NATUR	4:96
40	44452	TBRP, TÄTNINGSBRICKA RÖRPROPP				RÖD	4:96
40	44453	TBRP, TÄTNINGSBRICKA RÖRPROPP				GRÖN	4:96
40	44454	TBRP, TÄTNINGSBRICKA RÖRPROPP				BEIGE	4:96
41	44608	TÄTNINGSRING, DUBBELSIDIG					4:96
42	44660	SKYDDSPLOGG				SVART	4:97
42	44661	SKYDDSPLOGG				VIT	4:97
42	44662	SKYDDSPLOGG				RÖD	4:97
42	44663	SKYDDSPLOGG				GRÖN	4:97
42	44664	SKYDDSPLOGG				BEIGE	4:97
42	44665	SKYDDSPLOGG, TYP B				GUL	4:97
43	44600	SK, SKYDDSKAPSEL FÖR SKRUV o MUTTER				SVART	4:97
43	44601	SK, SKYDDSKAPSEL FÖR SKRUV o MUTTER				VIT	4:97
43	44602	SK, SKYDDSKAPSEL FÖR SKRUV o MUTTER				RÖD	4:97
43	44603	SK, SKYDDSKAPSEL FÖR SKRUV o MUTTER				GRÖN	4:97
43	44604	SK, SKYDDSKAPSEL FÖR SKRUV o MUTTER				BEIGE	4:97
44	44600	SKYDDSHUV				SVART	4:97
45	44610	SKYDDSHUV, KULLRIG SKRUV				SVART	4:98
45	44611	SKYDDSHUV, KULLRIG SKRUV				VIT	4:98
45	44612	SKYDDSHUV, KULLRIG SKRUV				RÖD	4:98
45	44613	SKYDDSHUV, KULLRIG SKRUV				GRÖN	4:98
46	44620	SKYDDSHUV, POZI				SVART	4:98
46	44621	SKYDDSHUV, POZI				VIT	4:98
46	44622	SKYDDSHUV, POZI				RÖD	4:98
46	44623	SKYDDSHUV, POZI				GRÖN	4:98
46	44624	SKYDDSHUV, POZI				BEIGE	4:98

BILD	ART.GR.	BENÄMNING	DIN	ISO	KVAL	YTBEH	SIDA
47	44630	SKYDDSHUV, SPÅR				SVART	4:98
47	44631	SKYDDSHUV, SPÅR				VIT	4:98
47	44632	SKYDDSHUV, SPÅR				RÖD	4:98
47	44633	SKYDDSHUV, SPÅR				GRÖN	4:98
47	44634	SKYDDSHUV, SPÅR				BEIGE	4:98
48	44640	SKYDDSHUV, FÖSÄNKT INSEX				SVART	4:98
48	44641	SKYDDSHUV, FÖSÄNKT INSEX				VIT	4:98
48	44642	SKYDDSHUV, FÖSÄNKT INSEX				GRÖN	4:98
48	44643	SKYDDSHUV, FÖSÄNKT INSEX				RÖD	4:98
48	44644	SKYDDSHUV, FÖSÄNKT INSEX				BEIGE	4:98
49	44650	SKYDDSHUV, INSEX				SVART	4:98
49	44651	SKYDDSHUV, INSEX				VIT	4:98
49	44652	SKYDDSHUV, INSEX				GRÖN	4:98
49	44653	SKYDDSHUV, INSEX				RÖD	4:98
49	44654	SKYDDSHUV, INSEX				BEIGE	4:98
50	44670	SKRUVPLUGG, GPN 700, form A				GUL	4:92
51	44676	SKYDDSPROPP				BLÅ	4:92
52	44680	PLASTFOT, TYP VL				SVART	4:92
53	44685	SKYDDSPLUGG, KONISK, TYP C				NATUR	4:94

KOPPAR

1	54000	RB, PLANBRICKA	125	7089			4:70
1	54080	TBR, TÄTNINGSBRICKA	7603				4:71
2	54070	RBS, STOR PLANBRICKA	9021	7093			4:70
10	54135	FB, FÖRSÄNKT BRICKA 90°, 110°					4:71
11	54140	FBB, FJÄDERBRICKA	127				4:72
13	54150	KBA, KUPAD BRICKA	137A				4:72
14	54155	KBB, KUPAD BRICKA	137B				4:72

ALUMINIUM

1	64000	RB, PLANBRICKA	125	7089			4:80
1	64030	NB, NITBRICKA					4:80
1	64080	TBR, TÄTNINGSBRICKA	7603				4:81
2	64070	RBS, STOR PLANBRICKA	9021	7093			4:80
10	64135	FB, FÖRSÄNKT BRICKA 90°, 110°					4:81
11	64140	FBB, FJÄDERBRICKA	~127				4:81

SWEBOLT AB

TEL. 08-584 909 60 FAX. 08-583 581 82

BILD ART.GR. BENÄMNING DIN ISO KVAL YTBEH SIDA

TITAN

1 74000 RB, PLANBRICKA 125A 7089 4:110

FIBER

1 84000 RB, PLANBRICKA 125A 7089 4:116

TENNBRONS

11 94140 FBB, FJÄDERBRICK 127 4:120

13 94150 KBB, KUPAD BRICKA 137A 4:120

17 94170 LB-AZ, LÅSBRICKA 6798A 4:121

18 94172 LB-IZ, LÅSBRICKA 6798J 4:121

20 94180 RRB, RÄFFLAD BRICKA schnorr 4:120

SWEBOLT AB

TEL. 08-584 909 60 FAX. 08-583 581 82



ARTIKELLISTA

2013-2014

PLANBRICKA BRB DIN 125

OBEH - FZB - FZV - DELTA

BRB HV200 / HB 200						RB DIN 125 HV140					HV
C:A PRIS/100 ST						C:A PRIS/100 ST					300
DIM	di x Dy x t	OBEH	FZB	FZV	SVOX	DIM	di x Dy x t	OBEH	FZB	FZV	FZB
M3	3.2x6x0.5	X	X		X	M2	2.2x5x0.3	X	X		
M4	4.3x8x0.8	X	X		X	M2.5	2.7x6x0.5	X	X		
M5	5.3x10x1	X	X		X	M3	3.2x7x0.5	X	X		
M6	6.4x12x1.5	X	X	X	X	M4	4.3x9x0.8	X	X		
M7	7.4x14x1.5		X			M5	5.3x10x1	X	X		
M8	8.4x16x1.5	X	X	X	X	M6	6.4x12x1.6	X	X		
M10	10.5x22x2	X	X	X	X	M8	8.4x16x1.6	X	X	X	
RB M10	10.5x20x2	X	X	X		M10	10.5x20x2	X	X	X	X
M12	13x24x2	X	X	X	X	M12	13x24x2.5	X	X	X	X
RB M12	13x24x2.5	X	X	X		M14	15x28x2.5	X	X	X	
M14	15x26x2	X	X	X		M16	17x30x3	X	X	X	X
M16	17x30x3	X	X	X		M18	19x34x3	X	X		
M18	19x34x3	X	X	X		M20	21x37x3	X	X	X	X
M20	21x36x3	X	X	X		M22	23x39x3	X	X		
RB M20	21x37x3	X	X	X		M24	25x44x4	X	X	X	X
M22	23x40x3	X	X	X		M27	28x50x4	X	X	X	X
M24	25x45x4	X	X	X		M30	31x56x4	X	X	X	X
M27	28x50x4	X	X	X		M33	34x60x5	X	X	X	
M30	31x56x4	X	X	X		M36	37x66x5	X	X	X	
M33	34x60x5	X	X	X		M39	40x72x6	X	X	X	
M36	37x66x5	X	X	X		M42	43x78x7	X	X	X	
1/4"	6.7x14x1.5		X	X		M45	46x85x7	X	X	X	
5/16"	8.4x16x1.5		X	X		M48	50x92x8	X	X	X	
3/8"	10x18x2		X	X	X	M52	54x98x8	X	X	X	
7/16"	12x22x2		X	X		M56	58x105x9	X	X	X	
1/2"	13.5x24x2		X	X		M60	62x110x9	X	X	X	
9/16"	15x26x2		X	X		M64	66x115x9	X	X	X	
5/8"	17x30x3		X	X		M72	74x125x10	X	X	X	
3/4"	20x36x3		X	X		M80	82x140x12	X	X	X	
7/8"	23x40x3		X	X							
1"	26x45x4	X	X	X							

KRYSSMARKERADE ARTIKLAR MOT FÖRFRÅGAN !
ÖVRIGA DIMENSIONER MOT FÖRFRÅGAN !

FÖRP.	OBEH	FZB	FZV	SVOX
1000 ST				
500 ST	M3-	M3-		M3-
200 ST	M6-	M6-	M6-	
100 ST	M16-	M14-	M14-	
50 ST	M30-	M30-	M30-	
25 ST				

FÖRP.	OBEH	FZB	FZV	FZB
1000 ST	M6-	M2-		
500 ST	M10-	M4-		
200 ST	M16-	M6-	M8-	M10-
100 ST	M24-	M14-	M16-	M16-
50 ST	M30-	M30-	M30-	
25 ST	M42-	M42-	M42-	

BESTÄLLNINGSEXEMPEL: 14000100 - BRB M10 HB200 OBEH
 BESTÄLLNINGSEXEMPEL: 14001100 - BRB M10 HB200 FZB
 BESTÄLLNINGSEXEMPEL: 14002100 - BRB M10 HB200 FZV
 BESTÄLLNINGSEXEMPEL: 14019080 - BRB M8 HB200 SVOX
 BESTÄLLNINGSEXEMPEL: 14007120 - RB M12 HV140 FZB
 BESTÄLLNINGSEXEMPEL: 14008120 - RB M12 FV140 FZV

SWEBOLT AB

TEL 08 - 555 975 00 FAX 08 - 583 581 82

ARTIKELLISTA
2013-2014
BRICKA BRFB HB 200
BRICKA RB DIN 126
OBEH - FZB - FZV



BRFB HB 200					RB DIN 126				
C:A PRIS/100 ST					C:A PRIS/100 ST				
DIM	di x Dy x t	OBEH	FZB	FZV	DIM	di x Dy x t	OBEH	FZB	FZV
M20	21x36x3	X	X	X	M10	11x20x2	X	X	X
M22	23x40x3	X	X	X	M12	13.5x24x2.5	X	X	X
M24	25x45x4	X	X	X	M14	15.5x28x2.5	X	X	X
M27	28x52x4	X	X	X	M16	17.5x30x3	X	X	X
M30	31x58x4	X	X	X	M18	20x34x3	X	X	X
M33	34x62x4	X	X	X	M20	22x37x3	X	X	X
M36	37x68x5	X	X	X	M22	24x39x3	X		
M39	40x75x5	X	X	X	M24	26x44x4	X	X	X
M42	43x80x6	X	X	X	M27	30x50x4	X	X	X
M45	46x85x6	X	X	X	M30	33x56x4	X	X	X
M48	50x92x6	X	X	X	M33	36x60x5	X	X	X
					M36	39x66x5	X	X	X
3/4"	20x36x3	X	X	X	M39	42x72x6	X		
7/8"	23x40x3	X	X	X	M42	45x78x7	X		
1"	26x45x4	X	X	X	M45	48x85x7	X		
1 1/8"	30x52x4	X	X	X	M48	52x92x8	X		
1 1/4"	33x58x4	X	X	X	M52	56x98x8	X		
1 3/8"	36x62x5	X	X	X	M56	62x105x9	X		
1 1/2"	40x68x5	X	X	X	M60	66x110x9	X		
1 3/4"	46x80x6	X	X	X	M64	70x115x9	X		
2"	53x92x6	X	X	X	M72	78x125x10	X		

KRYSSMARKERADE DIMENSIONER MOT FÖRFRÅGAN !
 ÖVRIGA DIMENSIONER MOT FÖRFRÅGAN !

FÖRP.	OBEH	FZB	FZV
100 ST	M20-	M20-	M20-
50 ST	M27-	M27-	M27-
25 ST	M42-	M42-	M42-

FÖRP.	OBEH	FZB	FZV
500 ST	M10-	M10-	M10-
200 ST	M16-	M16-	M16-
100 ST	M24-	M24-	M24-
50 ST	M36-	M36-	M36-
25 ST	M42-	M42-	M42-
10 ST	M56-	M56-	M56-

INFORMATION !

ETT BRA ALTERNATIV TILL BRFB BRICKAN ÄR BRB BRICKAN PÅ SID 4:1
 SKILLNADEN ÄR DEN FAS SOM FINNS PÅ ENA YTTERKANTEN AV
 BRFB BRICKAN. FASEN FINNS INTE PÅ BRB BRICKAN.

BESTÄLLNINGSEXEMPEL: 14011270 - BRFB M27 OBEH

BESTÄLLNINGSEXEMPEL: 14012270 - BRFB M27 FZB

BESTÄLLNINGSEXEMPEL: 14013270 - BRFB M27 FZV

SWEBOLT AB

TEL 08-555 975 00 FAX 08-583 581 82

ARTIKELLISTA

2013-2014

RBS STOR PLANBRICKA DIN 9021

OBEH - FZB - FZV - DEPO



RBS DIN 9021					
C:A PRIS/100 ST					
DIM	di x Dy x t	OBEH	FZB	FZV	DEPO
M3	3.2x9x0.8	X	X	X	X
M4	4.3x12x1	X	X	X	X
M5	5.3x15x1.6	X	X	X	X
M6	6.4x18x1.6	X	X	X	X
M8	8.4x24x2	X	X	X	X
M10	10.5x30x2.5	X	X	X	X
M12	13x37x3	X	X	X	X
M14	15x45x3	X	X	X	X
M16	17x50x3	X	X	X	X
M18	20x56x4	X	X	X	X
M20	22x60x4	X	X	X	X

FÖRP.	OBEH	FZB	FZV	DEPO
500 ST	M6-	M3-	M3-	M3-
200 ST	M10-	M6-	M6-	M6-
100 ST	M16-	M12-	M12-	M12-

BESTÄLLNINGSEXEMPEL: 14071120 - RBS M12 FZB

SBRB / DIN 7989 HV200 FZV

SBRB HV200		
C:A PRIS/100ST		
DIM	di x Dy x t	FZV
M12	13x24x7	X
M16	17x30x7	X
M20	21x37x7	X
M22	23x39x7	X
M24	25x44x7	X

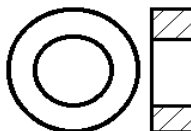

DIN 7989 HV200		
C:A PRIS/100ST		
DIM	di x Dy x t	FZV
M10	11x21x8	X
M12	14x24x8	X
M16	18x30x8	X
M20	22x37x8	X
M24	26x44x8	X
M27	30x50x8	X
M30	33x56x8	X
M33	36x60x8	X
M36	39x66x8	X

FÖRP	FZV
200 ST	M12-

BESTÄLLNINGSEXEMPEL: 14075160 - SBRB M16 FZV

BESTÄLLNINGSEXEMPEL: 14078160 - SBRB M16 FZV DIN 7989

FÖRP	FZV
200 ST	M12-
100 ST	M20-
50 ST	M33-

HVBRB EN 14399-6 C45

OBEH - FZB - FZV

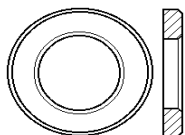

C:A PRIS/100ST				
DIM	di x Dy x t	OBEH	FZB	FZV
M12	13x24x3	X		X
M16	17x30x4	X		X
M20	21x37x4	X		X
M24	25x44x4	X		X
M27	28x50x5	X		X
M30	31x56x5	X		X
M33	34x60x5	X		X
M36	37x66x6	X		X
M42	43x78x7	X		X
M45	46x85x7	X		X



FÖRP	OBEH	FZB	FZV
200 ST	M12-		M12-
100 ST	M16-		M16-
50 ST	M30-		M30-

BESTÄLLNINGSEXEMPEL: 14072120 - HVBRB M12 OBEH

BESTÄLLNINGSEXEMPEL: 14074120 - HVBRB M12 FZV

SWEBOLT AB

TEL 08-555 975 00 FAX 08-583 581 82

ARTIKELLISTA
2013-2014
PLANBRICKA SRB
NITBRICKA NB
KAROSSERIBRICKA SRKB
OBEH - FZB - FZV



PLANBRICKA SRB				
C:A PRIS/100 ST				
DIM	OBEH	FZB	FZV	FORP
4x9x0.5				500 ST
4x10x1		X		500 ST
5.5x12x1		X		200 ST
7x12x1.5		X		200 ST
7x14x1.5		X		200 ST
7x16x1.5		X		200 ST
7x18x1.5		X		200 ST
8x14x1.5		X		200 ST
9x18x1.5		X	X	200 ST
11x18x2		X		200 ST
11x22x2		X	X	200 ST
12.5x22x2		X		200 ST
12.5x26x2		X		200 ST
14x24x2		X	X	200 ST
14x28x2		X	X	100 ST
17.5x30x3		X		100 ST
17.5x34x3		X	X	100 ST
17x40x3		X		100 ST
21x36x3			X	100 ST
21x40x3		X	X	100 ST
24x40x3	X	X	X	100 ST
24x45x3		X	X	100 ST
26x45x4		X		100 ST
27x45x4	X			100 ST
27x52x4		X		100 ST
29x52x4				100 ST
31x52x4		X	X	100 ST
31x58x4		X		100 ST
34x58x4		X		100 ST
34x62x4		X		100 ST
37x62x5		X		100 ST
37x68x5				50 ST
40x68x5	X			50 ST
40x75x5		X		50 ST
47x80x6				50 ST
47x85x6				50 ST
50x92x6				50 ST
54x92x6				50 ST
54x98x6				50 ST

NITBRICKA NB		
C:A PRIS/100 ST		
DIM	FZB	FORP
3x13x1	X	200 ST
4x16x1	X	200 ST
5x13x1	X	200 ST
5x16x1	X	200 ST
5x19x1	X	200 ST
5x22x1	X	200 ST
5x25x1	X	200 ST
6x16x1	X	200 ST
6x19x1	X	200 ST
6x22x1.5	X	200 ST
6x25x1.5	X	200 ST
7.8x19x1.5	X	200 ST
8x16x1.5	X	200 ST
8x19x1.5	X	200 ST
8x22x1.5	X	200 ST
8x25x1.0	X	200 ST
8x25x1.5	X	200 ST
10x19x1.5	X	200 ST
10x22x1.5	X	200 ST
10x25x1.5	X	200 ST

KAROSSERIBRICKA SRKB		
DIM	FZB	FORP
5.5x22x1.5	X	200 ST
5.5x25x1.5	X	200 ST
7x19x1.5	X	200 ST
7x22x1.5	X	200 ST
7x25x1.5	X	200 ST
7x28x2	X	100 ST
7x35x2	X	100 ST
7x35x3	X	100 ST
9x28x2	X	100 ST
9x35x2	X	100 ST
9x35x3	X	100 ST
11x28x2	X	100 ST
11x35x2	X	100 ST
11x35x3	X	100 ST
12.5x28x2	X	100 ST
12.5x35x2	X	100 ST
12.5x35x3	X	100 ST
12.5x50x3	X	100 ST
14x35x2	X	100 ST
14x35x3	X	100 ST
14x42x3	X	100 ST
17.5x50x3	X	100 ST
21x60x4	X	100 ST

BESTÄLLNINGSEXEMPEL: 14031051610 - NB 5X16X1 FZB
 BESTÄLLNINGSEXEMPEL: 14017142820 - SRB 14X28X2 FZB
 BESTÄLLNINGSEXEMPEL: 14018142820 - SRB 14X28X2 FZV
 BESTÄLLNINGSEXEMPEL: 14036113520 - SRKB 11X35X2 FZB

ÖVRIGA DIMENSIONER MOT FÖRFRÅGAN !

SWEBOLT AB
TEL 08-555 975 00 FAX 08-583 581 82

ARTIKELLISTA

2013-2014

FJÄDERBRICKA FBB - FBH

OBEH - FZB - FZV



FBB DIN 127B				
C:A PRIS/100 ST				
DIM	di x Dy x t	OBEH	FZB	FZV
M2	2.1x4.4x0.5	X	X	
M2.5	2.6x5.1x0.6	X	X	
M3	3.1x6.2x0.8	X	X	
M4	4.1x7.6x0.9	X	X	
M5	5.1x9.2x1.2	X	X	
M6	6.1x11.8x1.6	X	X	X
M7	7.1x12.8x1.6	X	X	
M8	8.1x14.8x2.0	X	X	X
M10	10.2x18.1x2.2	X	X	X
M12	12.2x21.1x2.5	X	X	X
M14	14.2x24.1x3.0	X	X	X
M16	16.2x27.4x3.5	X	X	X
M18	18.2x29.4x3.5	X	X	X
M20	20.2x33.6x4	X	X	X
M22	22.5x35.9x4	X	X	X
M24	24.5x40x5	X	X	X
M27	27.5x43x5	X	X	X
M30	30.5x48.2x6	X	X	X
M33	33.5x55.2x6	X	X	X
M36	36.5x58.2x6	X	X	X
M39	39.5x61.2x6	X	X	X
M42	42.5x68.2x7	X	X	X
M45	45.5x71.2x7	X	X	X
M48	49x75x7	X	X	X
M52	53x83x8	X	X	X
M56	57x87x8	X		
M60	61x91x8	X		
M64	65x95x8	X		

FBH DIN 128A				
C:A PRIS/100 ST				
DIM	di x Dy x t	OBEH	FZB	FZV
M2	2.1x4.4x0.5			
M2.5	2.6x5.1x0.6			
M3	3.1x6.2x0.7		X	
M3.5	3.6x6.7x0.7		X	
M4	4.1x7.2x0.8		X	
M5	5.1x9.2x1		X	
M6	6.1x11.8x1.3		X	
M7	7.1x12.8x1.3			
M8	8.2x14.8x1.6		X	
M10	10.2x18.1x1.8		X	
M12	12.2x21.1x2.1		X	
M14	14.2x24.1x2.4		X	
M16	16.2x27.4x2.8		X	
M18	18.2x29.4x2.8		X	
M20	20.2x33.6x3.2		X	
M22	22.5x35.9x3.2		X	
M24	24.5x40x4		X	
M27	27.5x43x4			
M30	30.5x48.2x6			
M36	36.5x58.2x6			
M39	39.5x59.5x6			
M42	42.5x68.2x7			
M48	49x75x7			
M52	53x83x8			

1/4"	6.5x12x1.3			
3/8"	9.7x17.6x1.8			
7/16"	11.3x20.2x2.1			
1/2"	13x22.8x2.4			
1"	26.2x41.7x4			
1 1/4"	33.5x55.2x6			

1/4"	6.4x12.2x1.6		X	
5/16"	8.1x14.8x2.0		X	
3/8"	9.7x17.6x2.2		X	
7/16"	11.2x19.1x2.2		X	
1/2"	13.2x22.4x2.5	X	X	
9/16"	14.2x24.1x3.0		X	
3/4"	19.3x32.6x4		X	
7/8"	22.5x35.9x4		X	
1"	26.5x42x5		X	
1 1/4"	32.5x50.3x6			
1 1/2"	39.5x61.2x6			
1 3/4"	45.5x71.2x7			
2"	53x83x8			

FÖRP.	OBEH	FZB	FZV
500 ST	M3-	M3-	M3-
200 ST	M6-	M6-	M6-
100 ST	M14-	M14-	M14-
50 ST			M27-

BESTÄLLNINGSEXEMPEL: 14141160 - FBB M16 FZB

BESTÄLLNINGSEXEMPEL: 14142160 - FBB M16 FZV

BESTÄLLNINGSEXEMPEL: 14146140 - FBH M14 FZB

ÖVRIGA DIMENSIONER MOT FÖRFRÅGAN !

FÖRP.	OBEH	FZB	FZV
500 ST	M3-	M3-	
200 ST	M6-	M6-	M6-
100 ST	M14-	M14-	M14-
50 ST		M30-	M30-

SWEBOLT AB

TEL 08-555 975 00 FAX 08-583 581 82



ARTIKELLISTA

2013-2014

KUPAD BRICKA KBA DIN 137A

KUPAD BRICKA KBB DIN 137B



KBA DIN 137A			
C:A PRIS/100 ST			
DIM	di x Dy x t	OBEH	FZB
M2	2.2x4.5x0.3		X
M2.5	2.7x5.5x0.3		X
M3	3.2x6x0.4	X	X
M4	4.3x8x0.5	X	X
M5	5.3x10x0.5	X	X
M6	6.4x11x0.5	X	X
M8	8.4x15x0.5	X	X
M10	10.5x18x0.8	X	X
M12	13x24x1.2	X	X
M14			
M16			
M18			
M20			
M22			
M24			
M27			

KBB DIN 137B			
C:A PRIS/100 ST			
DIM	di x Dy x t	OBEH	FZB
M2			
M2.5			
M3	3.2x8x0.5	X	X
M4	4.3x9x0.5	X	X
M5	5.3x11x0.5	X	X
M6	6.4x12x0.5	X	X
M8	8.4x15x0.8	X	X
M10	10.5x21x1	X	X
M12	13x24x1.2	X	X
M14	15x28x1.6	X	X
M16	17x30x1.6	X	X
M18	19x34x1.6	X	X
M20	21x36x1.6	X	X
M22	23x40x1.8	X	X
M24	25x44x1.8	X	X
M27	28x50x2		

FORP	OBEH	FZB
1000 ST	M4-	M3-
500 ST		
200 ST		
100 ST		

FORP	OBEH	FZB
1000 ST		M3-
500 ST		M12-
200 ST		M16-
100 ST		M24-



LÅSBRICKOR LB-AZ DIN 6798A YTTERTANDAD

LÅSBRICKOR LB-IZ DIN 6798J INNERTANDAD



LB-AZ DIN 6798A			
C:A PRIS/100 ST			
DIM	di x Dy x t	OBEH	FZB
M2	2.2x4.5x0.3		X
M2.5	2.7x5.5x0.4		X
M3	3.2x6x0.4		X
M4	4.3x8x0.5	X	X
M5	5.3x10x0.6	X	X
M6	6.4x11x0.7	X	X
M8	8.4x15x0.8	X	X
M10	10.5x18x0.9	X	X
M12	13x20.5x1	X	X
M14	15x24x1	X	X
M16	17x26x1.2	X	X
M18	19x30x1.4	X	X
M20	21x33x1.4	X	X
M22	23x36x1.5	X	X
M24	25x38x1.5	X	X
M27	28x44x1.6	X	X
M30	31x48x1.6	X	X

LB-IZ DIN 6798J			
C:A PRIS/100 ST			
DIM	di x Dy x t	OBEH	FZB
M2	2.2x4.5x0.3		X
M2.5	2.7x5.5x0.4		X
M3	3.2x6x0.4	X	X
M4	4.3x8x0.5	X	X
M5	5.3x10x0.6	X	X
M6	6.4x11x0.7	X	X
M8	8.4x15x0.8	X	X
M10	10.5x18x0.9	X	X
M12	13x20.5x1	X	X
M14	15x24x1	X	X
M16	17x26x1.2	X	X
M18	19x30x1.4	X	X
M20	21x33x1.4	X	X
M22	23x36x1.5	X	X
M24	25x38x1.5	X	X
M27	28x44x1.6	X	X
M30	31x48x1.6	X	X

ÖVRIGA DIMENSIONER MOT FÖRFRÅGAN !

FÖRP	OBEH	FZB
1000 ST		
500 ST		M2-
200 ST		M6-
100 ST		M20-

FÖRP	OBEH	FZB
1000 ST	M3-	M2-
500 ST		M4-
200 ST		M6-
100 ST		M20-

SWEBOLT AB

TEL 08-555 975 00 FAX 08-583 581 82

ARTIKELLISTA

2013-2014

TJOCK BRICKA

TBRB

OBEH - FZB - FZV

SVARVAT UTFÖRANDE UPP TILL M24



C:A PRIS/100 ST							
DIM	HÅL	YTTERM.	TJOCKL.	OBEH	FZB	FZV	FÖRP.
M6	6.4	12	3	X	X		200 ST
M8 (5/16)	8.4	16	3	X	X		200 ST
M10	10.5	22	4	X	X		200 ST
M12	13	24	4	X	X		200 ST
M16	17	30	6	X	X		100 ST
M20	21	36	6	X	X		100 ST
M22 (7/8)	23	40	6	X	X		100 ST
M24	25	45	8	X	X		50 ST
M30	31	58	8	X	X		50 ST
M36	37	68	10	X	X		50 ST
M39	40	68	10	X	X		25 ST
1/4"	6.7	14	3	X	X		200 ST
3/8"	10	18	4	X	X		200 ST
1/2"	13.5	24	4	X	X		200 ST
3/4"	20	36	6	X	X		100 ST

TJOCK BRICKA STOR YTTERDIAMETER

TBR SB

OBEH - FZB - FZV

SVARVAT UTFÖRANDE UPP TILL M24



C:A PRIS/100 ST							
DIM	HÅL	YTTERM.	TJOCKL.	OBEH	FZB	FZV	FÖRP.
M6	6.4	22	4	X	X	X	200 ST
M8 (5/16)	8.4	26	5	X	X	X	200 ST
M10	10.5	28	6	X	X	X	100 ST
M12	13	36	3	X	X		100 ST
M12	13	36	6	X	X	X	100 ST
M14	15	36	6	X	X		100 ST
M16	17	42	8	X	X	X	100 ST
M20	21	52	8	X	X	X	50 ST
M24	25	58	10	X	X	X	50 ST
M30	33	75	12	X	X	X	25 ST
1/4"	6.7	22	4	X	X		200 ST
3/8"	10	28	6	X	X		100 ST
1/2"	13.5	36	6	X	X		100 ST

BESTÄLLNINGSEXEMPEL: 14021100 - TBRB M10 FZB

BESTÄLLNINGSEXEMPEL: 14026100 - TBR SB M10 FZB

ÖVRIGA DIMENSIONER MOT FÖRFRÅGAN !

SWEBOLT AB

TEL 08 - 584 909 60 FAX 08 - 583 581 82

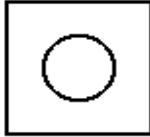

ARTIKELLISTA
2013-2014
BRICKOR
OBEH - FZB - FZV



S4B DIN 436				
C:A PRIS/100 ST				
DIM	di x Dy x t	OBEH	FZB	FZV
M6	7x20x2	X	X	X
M8	9x25x3	X	X	X
M10	11x30x3	X	X	X
M12	13.5x40x4	X	X	X
M14	14.2x40x4	X	X	X
M16	17.5x50x5	X	X	X
M20	22x60x5	X	X	X
M22	24x70x5	X	X	X
M24	26x80x6	X	X	X
M27	30x90x6	X	X	X
M30	33x95x6	X	X	X
M33	36x100x6	X	X	X
M36	38x110x6	X	X	X
FÖRP.	OBEH	FZB	FZV	
200 ST		M6-	M6-	
100 ST			M10-	M10-
50 ST			M16-	M12-
25 ST			M24-	M16-

HV 200	FZB	FZV
	X	
	X	X
	X	X
	X	X
	X	X
	X	X
	X	X
	M27 28x80x8	
M30 33x95x6		X
M30 32x80x10		X
M30 32x100x10		X
M33 36x100x8		X
M33 36x100x10		X

4BB
OBEH - FZB - FZV

4BB				
C:A PRIS/100 ST				
DIM	di x Dy x t	OBEH	FZB	FZV
3/8"	11x40x4	X	X	X
	11x50x5	X	X	X
1/2"	14x50x4	X	X	X
M12	14x60x6	X	X	X
M16	17.5x60x6	X	X	X
5/8"	17.5x65x4	X	X	X
3/4"	21x75x7	X	X	X
7/8"	24x85x8	X	X	X
1"	27x100x8	X	X	X
FÖRP.	OBEH	FZB	FZV	
50 ST			3/8"-	3/8"-
25 ST			3/4"-	3/4"-

S4B-GB
FZV

S4B-GB		
C:A PRIS/100 ST		
DIM	di x Dy x t	FZV
M20	22x50x8	X
M24	25x50x8	X
M27	28x60x10	X
M27	28x80x8	X
M30	32x60x10	X
M30	32x100x10	X
M33		X
M36	38x70x10	X
M36	38x100x10	X

BESTÄLLNINGSEXEMPEL: 14101120 - S4B M12 FZB
 BESTÄLLNINGSEXEMPEL: 14102120 - S4B M12 FZV
 BESTÄLLNINGSEXEMPEL: 14111120 - 4BB M12 FZB
 BESTÄLLNINGSEXEMPEL: 14112120 - 4BB M12 FZV
 BESTÄLLNINGSEXEMPEL: 14105270 - S4B-GB M27 FZV

ÖVRIGA DIMENSIONER MOT FÖRFRÅGAN !

SWEBOLT AB
 TEL 08 - 555 975 00 FAX 08 - 583 581 82

ARTIKELLISTA

2013-2014

PLANBRICKA UTAN FAS

PB ISO 7092 / DIN 433

OBEH - FZB - FZV



C:A PRIS/100 ST					
DIM	di x Dy x t	OBEH	FZB	FZV	FÖRP.
M1	1.1x2.5x0.3	X	X		
M1.2	1.3x3x0.3	X	X		
M1.4	1.5x3x0.3	X	X		
M1.6	1.7x3.5x0.3	X	X		
M1.8	2x4x0.3	X	X		
M2	2.2x4.5x0.3	X	X		
M2.5	2.7x5x0.5	X	X		
M3	3.2x6x0.5	X	X		
M3.5	3.7x7x0.5	X	X		
M4	4.3x8x0.5	X	X		
M5	5.3x9x1	X	X		
M6	6.4x11x1.6	X	X		
M8	8.4x15x1.6	X	X		
M10	10.5x18x1.6	X	X		
M12	13x20x2	X	X		
M14	15x24x2.5	X	X		
M16	17x28x2.5	X	X		
M18	19x30x2.5	X	X		
M20	21x34x3	X	X		

BESTÄLLNINGSEXEMPEL: 14051120 - PB M12 FZB



FJÄDERRING FR DIN 74361C

OBEH - FZB - FZV

C:A PRIS/100 ST					
DIM	Dy x di x t	OBEH	FZB	FZV	FÖRP.
12,5	12.5x12x1.5	X	X		100 ST
14,5	14.5x14x1.5	X	X		100 ST
16,5	16.5x16x1.5	X	X		100 ST
18,5	18.5x18x1.5	X	X		50 ST
20,5	20.5x20x1.5	X	X		50 ST
22,5	22.5x20x1.5	X	X		50 ST

BESTÄLLNINGSEXEMPEL: 14230180 - FR 18,5 OBEH

ÖVRIGA DIMENSIONER MOT FÖRFRÅGAN !

SWEBOLT AB

TEL 08 - 555 975 00 FAX 08 - 583 581 82

ARTIKELLISTA

2013-2014

LÅSBRICKA SCHNORR FJÄDERBRICKA FBR DIN 7980 OBEH - FZB

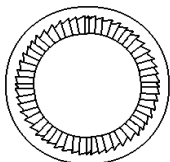

RRB SCHNORR - LÅSBRICKA			
C:A PRIS/100 ST			
DIM	di x Dy x t	OBEH	FZM
M4	4.3x7x0.5	X	X
M5	5.3x9x0.6	X	X
M6	6.4x10x0.7	X	X
M8	8.4x13x0.8	X	X
M10	10.5x16x1	X	X
M12	13x18x1.1	X	X
M14	15x22x1.2	X	X
M16	17x24x1.3	X	X
M18	19x27x1.5	X	X

FORP.	OBEH	FZB
1000 ST	M4-	
500 ST	M12-	
200 ST		

FBR FÖR INSEXSKRUV		
C:A PRIS/100 ST		
DIM	di x Dy x t	FZB
M3	3.1x5.6x1	X
M4	4.1x7x1.2	X
M5	5.1x8.8x1.6	X
M6	6.1x9.9x1.6	X
M8	8.1x12.7x2	X
M10	10.2x16x2.5	X
M12	12.2x18x2.5	X
M14	14.2x21.1x3	X
M16	16.2x24.4x3.5	X
M18	18.2x26.4x3.5	X
M20	20.2x30.6x4.5	X
M22	22.5x32.9x4.5	X
M24	24.5x35.9x5	X
M27	27.5x38.9x5	X
M30	30.5x44.1x6	X

FORP.	FZB
500 ST	M3-
200 ST	M6-
100 ST	M14-

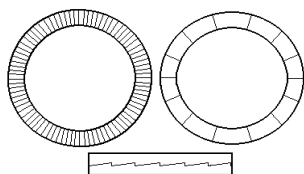

NORDLOCK - LIMMAD					
C:A PRIS/100 ST					
DIM	di x Dy x t	DELTA	DIM	di x Dy x t	DELTA
M3	3.2x7x1.8	X	M20	21x30.7x3.7	X
M4	4.3x9x1.8	X	M22	22.9x34.5x3.7	X
M5	5.2x9x1.8	X	M24	25.1x39x3.7	X
M6	6.5x10.8x1.8	X	1"	27x39x3.7	X
M8	8.2x13.5x2.6	X	M27	28.5x42x4.8	X
M10	10.3x16.6x2.6	X	M30	30.5x47x4.8	X
M12	13x19.5x2.6	X	M33	33.5x48.5x4.8	X
M14	14.5x23x3.7	X	M36	36.6x58.5x4.8	X
M16	17x25.4x3.7	X	M39	39.5x58.5x4.8	
M18	19.5x29x3.7	X	M42	42.5x58.5x4.8	

FORP.	FZB
200 ST	M6-
100 ST	M14-
50 ST	M27-
25 ST	M33-

BESTÄLLNINGSEXEMPEL
14180100 - RRB M10 SCHNORR
14144100 - FBR M10 FZB
14131100 - NL M10 LIMMAD

SWEBOLT AB

TEL 08-555 975 00 FAX 08-583 581 82

ARTIKELLISTA

2013-2014

BRICKOR

UBB DIN 434

OBEH - FZB - FZV

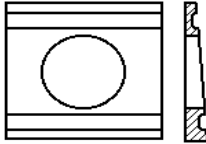

UB DIN 434				
C:A PRIS/100 ST				
DIM	di x 4-kant	OBEH	FZB	FZV
M8	9X22	X	X	X
M10	11X22	X	X	X
M12	14X26	X	X	X
M16	18X32	X	X	X
M20	22X40	X	X	X
M22	24X44	X	X	X
M24	26X56	X	X	X
M27	30x56	X	X	X
M30	33x62	X	X	X

FÖRP.	OBEH.	FZB	FZV
200 ST		M8-	M8-
100 ST		M16-	M16-
50 ST		M20-	M20-

BESTÄLLNINGSEXEMPEL: 14117200 - UBB M20 FZV

UB14 - 14% U-BALKSBRICKA

OBEH - FZB - FZV

UB DIN 435				
C:A PRIS/100 ST				
DIM	di x 4-kant	OBEH	FZB	FZV
M8	9x22	X	X	X
M10	11x22	X	X	X
M12	14x26	X	X	X
M16	18x32	X	X	X
M20	22x40	X	X	X
M22	24x44	X	X	X
M24	26x56	X	X	X
M27	30x56	X	X	X
M30	33x62	X	X	X

BESTÄLLNINGSEXEMPEL: 14122160 - UB14 M16 FZV

ÖVRIGA DIMENSIONER MOT FÖRFRÅGAN !

SWEBOLT AB

TEL 08 - 555 975 00 FAX 08 - 583 581 82

ARTIKELLISTA
2013-2014
FÖRSÄNKT BRICKA
FB SN 213912 90°
OBEH - FZB



C:A PRIS/100 ST			
DIM	di x Dy x h	OBEH	FZB
M2.5	2.7x9x1.6	X	X
M3	3.2x10x1.8	X	X
M4	4.3x14x2.3	X	X
M5	5.3x16x2.8	X	X
M6	6.4x18x3.3	X	X
M8	8.4x25x4.8	X	X

ÖVRIGA DIMENSIONER MOT FÖRFRÅGAN !

FÖRP.	OBEH	FZB
200 ST		M5-
100 ST		M6-

BESTÄLLNINGSEXEMPEL: 14136060 - FB M6 FZB

SWEBOLT AB
TEL 08-555 975 00 FAX 08-583 581 82

ARTIKELLISTA

2013-2014

BRICKOR

LB-AT DIN 6797A

OBEH - FZB - FZV

LB-AT				
C:A PRIS/100 ST				
DIM	di x Dy x t	OBEH	FZB	FZV
M3	3.2x6x0.4	X	X	X
M4	4.3x8x0.5	X	X	X
M5	5.3x10x0.6	X	X	X
M6	6.4x11x0.7	X	X	X
M8	8.4x15x0.8	X	X	X
M10	10.5x18x0.9	X	X	X
M12	13x20.5x1	X	X	X
M16	17x26x1.2	X	X	X
M20	21x33x1.4	X	X	X

FÖRP.	OBEH.	FZB	FZV
200 ST		M8-	M8-
100 ST		M16-	M16-
50 ST		M20-	M20-

BESTÄLLNINGSEXEMPEL: 14161060 - LB-AT M6 FZB



LB-IT DIN 6797I OBEH - FZB - FZV

LB-IT				
C:A PRIS/100 ST				
DIM	di x Dy x t	OBEH	FZB	FZV
M3	3.2x6x0.4	X	X	X
M4	4.3x8x0.5	X	X	X
M5	5.3x10x0.6	X	X	X
M6	6.4x11x0.7	X	X	X
M8	8.4x15x0.8	X	X	X
M10	10.5x18x0.9	X	X	X
M12	13x20.5x1	X	X	X
M16	17x26x1.2	X	X	X
M20	21x33x1.4	X	X	X

BESTÄLLNINGSEXEMPEL: 14163100 - LB-IT M10 FZB

ÖVRIGA DIMENSIONER MOT FÖRFRÅGAN !

SWEBOLT AB

TEL 08 - 555 975 00 FAX 08 - 583 581 82

ARTIKELLISTA
2013-2014
LÅSBRICKA / VIKBRICKA
DIN 93
FZB



C:A PRIS/100 ST			
DIM	MÅTT	OBEH	FZB
M5	5.3x17x0.5	X	X
M6	6.4x19x0.5	X	X
M8	8.4x22x0.75	X	X
M10	10.5x26x0.75	X	X
M12	13x30x1	X	X
M16	17x36x1	X	X
M20	21x42x1	X	X
M24	25x50x1	X	X

FÖRP.	OBEH	FZB
200 ST		M5-
100 ST		M6-

BESTÄLLNINGSEXEMPEL: 14191160 - LB1 M16 FZB

LÅSBRICKA / VIKBRICKA
DIN 463
FZB



C:A PRIS/100 ST			
DIM	MÅTT	OBEH	FZB
M4	4.3x9x0.38	X	X
M5	5.3x10x0.5	X	X
M6	6.4x12.5x0.5	X	X
M8	8.4x17x0.75	X	X
M10	10.5x21x0.75	X	X
M12	13x24x1	X	X
M14	15x28x1	X	X
M16	17x30x1	X	X
M20	21x37x1	X	X
M24	25x44x1	X	X
M27	28x50x1.6	X	X
M30	31x56x1.6	X	X

ÖVRIGA DIMENSIONER MOT FÖRFRÅGAN !

FÖRP.	OBEH	FZB
200 ST		M5-
100 ST		M6-

BESTÄLLNINGSEXEMPEL: 14196100 - LB2 M10 FZB

SWEBOLT AB

TEL 08-555 975 00 FAX 08-583 581 82

ARTIKELLISTA

2013-2014

TRB STOR BRICKA DIN 440R FÖR TRÄ OBEH - FZB



C:A PRIS/100ST				
DIM	di x Dy x t	OBEH	FZB	FZV
M5	5.5x18x2	X	X	X
M6	6.6x22x2	X	X	X
M8	9x28x3	X	X	X
M10	11x34x3	X	X	X
M12	14x45x4	X	X	X
M14	15.5x50x4	X	X	X
M16	18x58x5	X	X	X
M20	22x68x5	X	X	X
M22	24x80x6	X	X	X
M24	26x92x6	X	X	X
M27	30x98x6	X	X	X
M30	33x105x6	X	X	X
M33	36x112x6	X	X	X
M36	39x125x8	X	X	X

FÖRP	OBEH	FZB	FZV
200 ST	M8-	M8-	M8-
100 ST	M16-	M16-	M16-
50 ST	M20-	M20-	M20-
25 ST	M27-	M27-	M27-

RB4 BRICKA MED FYRKANTHÅL DIN 440V OBEH - FZB



C:A PRIS/100ST			
DIM	ix Dy x t	OBEH	FZB
M5	5.5x18x2	X	X
M6	6.6x22x2	X	X
M8	9x28x3	X	X
M10	11x34x3	X	X
M12	14x45x4	X	X
M14	15.5x50x4	X	X
M16	18x58x5	X	X
M20	22x68x5	X	X
M22	24x80x6	X	X

ÖVRIGA DIMENSEIONER MOT FÖRFRÅGAN !

FÖRP	OBEH	FZB
200 ST		
100 ST		
50 ST		
25 ST		

SWEBOLT AB

TEL 08-555 975 00 FAX 08-583 581 82

ARTIKELLISTA
2013-2014
DIB LÅSBRICKA
DUBBELTANDAD
FZB



C:A PRIS/100 ST			
DIM	di x Dy x t	OBEH	FZB
M3	3.05x12.4x0.5	X	X
M4	4.2x15.6x0.8	X	X
M4	4.2x17.9x0.8	X	X
M5	5.1x17.9x0.8	X	X
M6	6.1x18.2x0.9	X	X
M8	8.2x22.25x1	X	X
M8	8.2x27.5x1.1	X	X
M10	10.2x26.1x1.1	X	X
M12	12.3x30.3x1.2	X	X
M16	16.3x36.1x1.4	X	X

FÖRP.	OBEH	FZB
200 ST		M5-
100 ST		M6-

BESTÄLLNINGSEXEMPEL: 14126050 - DIB M5 FZB

SFÄRISK BRICKA
DIN 6319 C+D+G
OBEHANDLAD



C:A PRIS/100 ST				
DIM	di x Dy x t	TYP C	TYP D	TYP G
M6		X	X	X
M8		X	X	X
M10		X	X	X
M12		X	X	X
M14		X	X	X
M16		X	X	X
M20		X	X	X
M24		X	X	X
M27		X	X	X
M30		X	X	X
M42		X	X	X

ÖVRIGA DIMENSIONER MOT FÖRFRÅGAN !

FÖRP.	TYP C	TYP D	TYP G
200 ST			
100 ST			

BESTÄLLNINGSEXEMPEL: 14233120 - SFÄRISK BRICKA M12 TYP C

BESTÄLLNINGSEXEMPEL: 14234160 - SFÄRISK BRICKA M16 TYP D

BESTÄLLNINGSEXEMPEL: 14235240 - SFÄRISK BRICKA M24 TYP G

SWEBOLT AB

TEL 08-555 975 00 FAX 08-583 581 82

ARTIKELLISTA

2013-2014

PLANBRICKA FÖR FRP

PB-FRP DIN 7349

OBEH - FZB - FZV



C:A PRIS/100 ST					
DIM	di x Dy x t	OBEH	FZB	FZV	FÖRP.
M3	3.2x9x1				1000 ST
M3.5					1000 ST
M4	4.3x12x1.6				1000 ST
M5	5.3x15x2				1000 ST
M6	6.4x17x3		X		500 ST
M8	8.4x21x4		X		250 ST
M10	10.5x25x4		X		250 ST
M12	13x30x6		X		250 ST
M14	15x36x6				250 ST
M16	17x40x6	X	X		100 ST
M18	19x44x8				100 ST
M20	21x44x8				100 ST
M22	23x50x8				100 ST
M24	25x50x10				50 ST
M27	28x60x10				50 ST
M30	31x68x10				25 ST

BESTÄLLNINGSEXEMPEL: 10454120 - PB-FRP M12 FZB

ÖVRIGA DIMENSIONER MOT FÖRFRÅGAN !

SWEBOLT AB

TEL 08 - 555 975 00 FAX 08 - 583 581 82

ARTIKELLISTA

2013-2014

PLANBRICKA BRB DIN 125

NITBRICKA RBS DIN 9021

ROSTFRI A2 - SYRAFAST A4

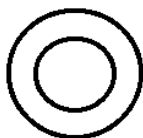

BRB DIN 125				
C:A PRIS/100 ST				
DIM	di x Dy x t	A2	A4	HRB A4 HV250
M2	2.2x5x0.3	X	X	
M2.5	2.7x5.5x0.5	X	X	
M3	3.2x7x0.5	X	X	
M4	4.3x9x0.8	X	X	
M5	5.3x10x1	X	X	
M6	6.4x12x1.6	X	X	
M8	8.4x16x1.6	X	X	
M10	10.5x20x2	X	X	
M12	13x24x2.5	X	X	
M14	15x28x2.5	X	X	
M16	17x30x3	X	X	
M18	19x34x3	X	X	
M20	21x37x3	X	X	
M22	23x39x3	X	X	
M24	25x44x4	X	X	
M27	28x50x4	X	X	
M30	31x56x4	X	X	
M33	34x60x5		X	
M36	37x66x5		X	
M42	43x78x7		X	
1/4"	6.7x14x1.5		X	
1/2"	13.5x24x2		X	

RBS DIN 9021			
C:A PRIS/100 ST			
DIM	di x Dy x t	A2	A4
M2	2.2x5x0.3		
M2.5	2.7x8x0.8		
M3	3.2x9x0.8		X
M4	4.3x12x1	X	X
M5	5.3x15x1.2	X	X
M6	6.4x18x1.6	X	X
M8	8.4x24x2	X	X
M10	10.5x30x2.5	X	X
M12	13x37x3	X	X
M14	15x44x3	X	
M16	17x50x3	X	X
M18	20x56x4		X
M20	22x60x4		X
M22			
M24	25x72x5		X
M27			
M30			
M33			
M36			

ÖVRIGA DIMENSIONER MOT FÖRFRÅGAN !

FÖRP.	A2	A4	HRB A4
1000 ST	M2-	M2-	
200 ST	M3-	M3-	
100 ST	M10-	M10-	
50 ST	M24-	M24-	
25 ST	M33-	M33-	

FÖRP.	A2	A4
500 ST		
200 ST	M4-	M3-
100 ST	M8-	M8-
50 ST		M20-
25 ST		

BESTÄLLNINGSEXEMPEL: 24000080 - BRB M8 A2

BESTÄLLNINGSEXEMPEL: 24001080 - BRB M8 A4

BESTÄLLNINGSEXEMPEL: 24070120 - RBS M12 A2

BESTÄLLNINGSEXEMPEL: 24071120 - RBS M12 A4

BESTÄLLNINGSEXEMPEL: 24046120 - HRB M12 A4 HV250

SWEBOLT AB

TEL 08 - 555 975 00 FAX 08 - 583 581 82

ARTIKELLISTA

2013-2014

FJÄDERBRICKA FBB DIN 127B

KUPAD BRICKA KBA DIN 137A

ROSTFRI A2 - SYRAFAST A4



FBB DIN 127B			
C:A PRIS/100 ST			
DIM	di x Dy x t	A2	A4
M2	2.1x4.4x0.5	X	
M2.5	2.6x5.1x0.6		X
M3	3.1x6.2x1.6	X	X
M4	4.1x7.6x1.8	X	X
M5	5.1x9.2x2.4	X	X
M6	6.1x11.8x3.2	X	X
M8	8.1x14.8x4	X	X
M10	10.2x18.1x4.4	X	X
M12	12.2x21.1x5	X	X
M14	14.2x24.1x6		X
M16	16.2x27.4x7	X	X
M18	18.2x29.4x7		X
M20	20.2x33.6x8		X
M22	22.5x35.9x8		X
M24	24.5x40x10		X
M27	27.5x43x10		X
M30	30.5x48.2x12		X

KBA DIN 137A			
C:A PRIS/100 ST			
DIM	di x Dy x h x t	A2	A4
M1.2	1.3x3x0.35x0.2		
M1.6	1.7x4x0.45x0.25	X	
M2	2.2x4.5x0.5x0.3	X	
M3	3.2x6x0.65x0.4	X	
M4	4.3x8x0.8x0.5	X	
M5	5.3x10x0.9x0.5	X	
M6	6.4x11x1.1x0.5	X	
M8	8.4x15x1.7x0.5	X	
M10	10.5x18x2x0.8	X	
M12			
M14			
M16			
M18			
M20			
M22			
M24			
M30			

FÖRP.	A2	A4
500 ST	M3-	M3-
200 ST	M4-	M4-
100 ST	M10-	M10-
50 ST	M16-	M16-
25 ST	M24-	M24-

FÖRP.	A2	A4
500 ST	M4-	
200 ST	M8-	
100 ST		
50 ST		
25 ST		



LÅSBRICKA LB-AZ DIN 6798A YTTERTANDAD

LÅSBRICKA LB-IZ DIN 6798J INNERTANDAD

ROSTFRI A2 - SYRAFAST A4

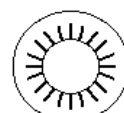

LB-AZ DIN 6798A			
C:A PRIS/100 ST			
DIM	di x Dy x t	A2	A4
M3	3.2x6x0.4	X	X
M4	4.3x8x0.5		X
M5	5.3x10x0.6		X
M6	6.4x11x0.7	X	X
M8	8.4x15x0.8	X	X
M10	10.5x18x0.9	X	X
M12	13x20.5x1		X
M14	15x24x1		X
M16	17x26x1.2		X
M18	19x30x1.4		X
M20	21x33x1.4		X
M22	23x36x1.5		X
M24	25x38x1.5		X

LB-IZ DIN 6798J			
C:A PRIS/100 ST			
DIM	di x Dy x t	A2	A4
M3	3.2x6x0.4		X
M4	4.3x8x0.5		X
M5	5.3x10x0.6		X
M6	6.4x11x0.7		X
M8	8.4x15x0.8		X
M10	10.5x18x0.9		X
M12	13x20.5x1		X
M14	15x24x1		X
M16	17x26x1.2		
M18	19x30x1.4		
M20	21x33x1.4		
M22	23x36x1.5		

ÖVRIGA DIMENSIONER MOT FÖRFRÅGAN !

FÖRP.	A2	A4
200 ST	M3-	M3-
100 ST	M12-	M12-

FÖRP.	A2	A4
200 ST	M3-	M3-
100 ST	M12-	M12-

SWEBOLT AB

TEL 08-555 975 00 FAX 08-583 581 82

ARTIKELLISTA
2013-2014
LÅSBLECK DIN 93
ROSTFRI - SYRAFAST



C:A PRIS/100 ST			
DIM	MÅTT	A2	A4
5	5,3x17x0,5	X	
6	6,4x19x0,5	X	X
8	8,4x22x0,75	X	X
10	10,5x26x0,75	X	X
12	13x30x1	X	X
16	17x36x1	X	X
20	21x42x1	X	X
24	25x50x1	X	X

ÖVRIGA DIMENSIONER MOT FÖRFRÅGAN !

FÖRP.	A2	A4
200 ST	M5-	M5-
100 ST	M10-	M10-

BESTÄLLNINGSEXEMPEL: 24191100 - LB M10 A4

SWEBOLT AB

TEL 08 - 555 975 00 FAX 08 - 583 581 82

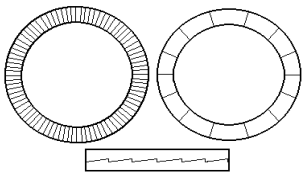

ARTIKELLISTA

2013-2014

NL NORDLOCK
SYRAFAST A4

NORDLOCK - LIMMAD					
C:A PRIS/100 ST					
DIM	di x Dy x t	A4	DIM	di x Dy x t	A4
M3	3.2x7x1.8	X	M20	21x30.7x3.7	X
M4	4.3x9x1.8	X	M22	22.9x34.5x3.7	X
M5	5.2x9x1.8	X	M24	25.1x39x3.7	X
M6	6.5x10.8x1.8	X	1"	27x39x3.7	X
M8	8.2x13.5x2.6	X	M27	28.5x42x4.8	X
M10	10.3x16.6x2.6	X	M30	30.5x47x4.8	X
M12	13x19.5x2.6	X	M33	33.5x48.5x4.8	X
M14	14.5x23x3.7	X	M36	36.6x58.5x4.8	X
M16	17x25.4x3.7	X	M39	39.5x58.5x4.8	X
M18	19.5x29x3.7	X	M42	42.5x58.5x4.8	X

FÖRP.	FZB
200 ST	M6-
100 ST	M14-
50 ST	M27-
25 ST	M33-

BESTÄLLNINGSEXEMPEL: 24131200 - NL M20 A4



SWEBOLT AB

TEL 08-555 975 00 FAX 08-583 581 82

ARTIKELLISTA
2013-2014
FYRKANTBRICKA DIN 436
ROSTFRI - SYRAFAST

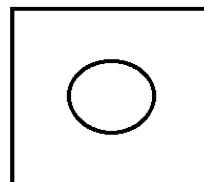

C:A PRIS/100 ST			
DIM	MÅTT	A2	A4
M10	11x30x3	X	X
M12	13,5x40x4	X	X
M16	17.5x50x5	X	X
M20	22x60x5	X	X
M22	24x70x6	X	X
M24	26x80x6	X	X

ÖVRIGA DIMENSIONER MOT FÖRFRÅGAN !

FÖRP.	A2	A4
100 ST	M10-	M10-
50 ST	M16-	M16-
25 ST	M20-	M20-

BESTÄLLNINGSEXEMPEL: 24101200 - S4B M20 A4

SWEBOLT AB

TEL 08 - 555 975 00 FAX 08 - 583 581 82

ARTIKELLISTA

2013-2014

BRICKA

BRB DIN 125

NYLON

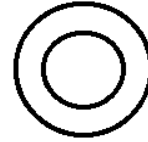

C:A PRIS/100 ST		
DIM	di x Dy x t	NYLON
M3	3.2x7x0.5	X
M4	4.3x9x0.8	X
M5	5.3x10x1	X
M6	6.4x12x1.6	X
M8	8.4x16x1.6	X
M10	10.5x20x2	X
M12	13x24x2.5	X
M16	17x30x3	
M20	21x37x3	
M24	25x45x4	











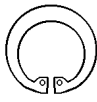
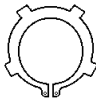

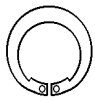
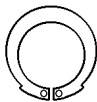
ÖVRIGA DIMENSIONER MOT FRÖFRÅGAN !

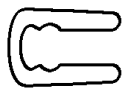
FÖRP.	NYLON
500 ST	M3-
200 ST	M8-
100 ST	M12-

BESTÄLLNINGSEXEMPEL: 44000060 - BRB M6 NYLON

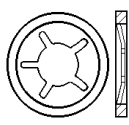
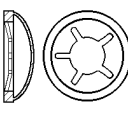
SWEBOLT AB

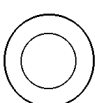
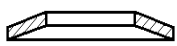
TEL 08 - 555 975 00 FAX 08 - 583 581 82

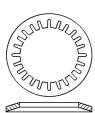
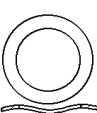
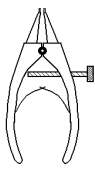
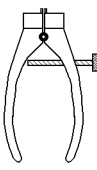
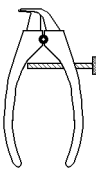
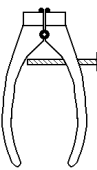
- 1 - 	- 2 - 	- 3 - 	- 4 - 
- 5 - 	- 6 - 	- 7 - 	- 8 - 
- 9 - 	- 10 - 	- 11 - 	- 12 - 
- 13 - 	- 14 - 	- 15 - 	- 16 - 
- 17 - 	- 18 - 	- 19 - 	- 20 - 
- 21 - 	- 22 - 	- 23 -	- 24 -
- 25 -	- 26 -	- 27 -	- 28 -
- 29 - 	- 30 - 	- 31 - 	- 32 - 

SWEBOLT AB

TEL. 08-584 909 60 FAX. 08-583 581 82

PRODUKTER I STÅL

1	15000	SGA, LÅSRING, AXEL	471			OBEH	5:1
1	15001	SGA, LÅSRING, AXEL	471			MFZG	5:1
2	15010	SGH, LÅSRING, HÅL	472			OBEH	5:1
2	15011	SGH, LÅSRING, HÅL	472			MFZG	5:1
3	15020	AK, LÅSRING m. LÄPP, HÅL	983			OBEH	5:6
4	15022	SGHL, LÅSRING m. LÄPP, AXEL	984			OBEH	5:6
5	15030	JV, LÅSRING U-TYP, AXEL				OBEH	5:6
6	15035	AV, LÅSRING, AXEL				OBEH	5:6
7	15040	SRA, SPÄNNRING, AXEL				OBEH	5:7
8	15050	RS, SPÄRRYTTARE, AXEL	6799			OBEH	5:1
8	15051	RS, SPÄRRYTTARE, AXEL	6799			FZB	5:1
9	15055	UC, U-CLIPS, AXEL				OBEH	5:7
9	15056	UC, U-CLIPS, AXEL				FZB	5:7
10	15060	AS, LÅSRING, AXEL				OBEH	5:8
10	15061	AS, LÅSRING, AXEL				FZB	5:8
11	15065	LTU, LÅSTRÅD U, AXEL				OBEH	5:8
11	15066	LTU, LÅSTRÅD U, AXEL				FZB	5:8
12	15070	RW, LÅSRING, AXEL RUND	7993A			OBEH	5:9
12	15071	RW, LÅSRING, AXEL RUND	7993A			MFZG	5:9
12	15072	SB, LÅSRING, AXEL				OBEH	5:9
12	15073	SB, LÅSRING, AXEL				FZB	5:9
13	15075	SW, SPÄNNRING, HÅL				OBEH	5:9
13	15176	SW, SPÄNNRING, HÅL				FZB	5:9
13	15080	RB, KLÄMLÅSRING, HÅL	7993B			OBEH	5:9
13	15081	RB, KLÄMLÅSRING, HÅL	7993B			MFZG	5:9
14	15300	ASL, AXELSÄKRING (A-LOCK - ARANLOCK)				OBEH	5:5
14	15301	ASL, AXELSÄKRING (A-LOCK - ARANLOCK)				FZB	5:5
15	15302	ASLK, AXELSÄKRINGSLÅS MED KAPSEL (STARLOCK)				OBEH	5:5
15	15303	ASLK, AXELSÄKRINGSLÅS MED KAPSEL (STARLOCK)				FZB	5:5
16	15085	KLB, KLÄMBRICKA, AXEL (STARLOCK)				OBEH	5:5
16	15086	KLB, KLÄMBRICKA, AXEL (STARLOCK)				FZB	5:5
17	15100	PB, PASSBRICKA, SHIMS	988			OBEH	5:2
18	15200	TF, TALLRIKSFJÄDER	2093 A, B, C			OBEH	5:3

SWEBOLT AB

TEL. 08-584 909 60 FAX. 08-583 581 82

BILD	ART.GR.	BENÄMNING	DIN	ISO	KVAL	YTBEH	SIDA
18	15251	SPB, KONISK SPÄNNBRICKA	6796			FZG	5:4
18	15252	SPB, KONISK SPÄNNBRICKA	6796			MFZG	5:4
19	15090	SKLB, SNABBKLÄMBRICKA				OBEH	5:10
19	15091	SKLB, SNABBKLÄMBRICKA				FZB	5:10
20	15320	TRG, TÄTNINGSRING STÅL/GUMMI				FZG	5:11
21	15330	BF, BRICKFJÄDER				OBEH	5:12
22	15340	VB, VÅGBRICKA				OBEH	5:13
29	15350	TÅNG, RAK, FÖR LÅSRINGAR					5:70
30	15351	TÅNG, RAK, FÖR LÅSRINGAR					5:70
31	15352	TÅNG, BÖJD, FÖR LÅSRINGAR					5:70
32	15353	TÅNG, BÖJD, FÖR LÅSRINGAR					5:70

ROSTFRITT / SYRAFAST

1	25000	SGA, LÅSRING, AXEL	471		A2		5:40
1	25001	SGA, LÅSRING, AXEL	471		A4		5:40
2	25010	SGH, LÅSRING, HÅL	472		A2		5:40
2	25011	SGH, LÅSRING, HÅL	472		A4		5:40
8	25050	RS, SPÅRRYTTARE, AXEL	6799		A2		5:41
14	25300	ASL, AXELSÄKRINGSLÅS (STARLOCK - QUICKLOCK)			A2		5:41
15	25302	ASLK, AXELSÄKRINGSLÅS m. KAPSEL			A2		5:41
18	25251	SPB, KONISK SPÄNNBRICKA	6796		A2		5:42
18	25252	SPB, KONISK SPÄNNBRICKA	6796		A4		5:42

KOPPAR

8	55050	RS, SPÅRRYTTARE, AXEL	6799		KOPPAR		5:60
---	-------	-----------------------	------	--	--------	--	------

TENNBRONS

8	95050	RS, SPÅRRYTTARE, AXEL	6799		TENN - BRONS		5:60
8	95051	RS, SPÅRRYTTARE, AXEL	6799		MAGNET. BRONS		5:60

SWEBOLT AB

TEL. 08-584 909 60 FAX. 08-583 581 82

ARTIKELLISTA

2013-2014

LÅSRINGAR

SGA DIN 471 / SGH DIN 472

OBEHANDLAT



C:A PRIS / 100 ST								
DIM.	SGA	SGH	DIM.	SGA	SGH	DIM.	SGA	SGH
3	X		37	X	X	100	X	X
4	X		38	X	X	102		X
5	X		40	X	X	105	X	X
6	X		42	X	X	110	X	X
7	X		45	X	X	112		X
8	X	X	47	X	X	115		X
9	X	X	48	X	X	120	X	X
10	X	X	50	X	X	125		X
11	X	X	52	X	X	127		
12	X	X	53		X	130	X	X
13	X	X	54	X	X	135		
14	X	X	55	X	X	140	X	X
15	X	X	56		X	145		
16	X	X	57	X	X	150	X	X
17	X	X	58	X	X	155		
18	X	X	60	X	X	160	X	X
19	X	X	62	X	X	165		
20	X	X	63	X	X	170	X	X
21	X	X	65	X	X	175		
22	X	X	68	X	X	180		X
23	X	X	70	X	X	185		
24	X	X	72	X	X	190	X	X
25	X	X	75	X	X	195		
26	X	X	78	X	X	200		X
27	X	X	80	X	X	220		
28	X	X	82	X	X	225		
29	X	X	85	X	X	230		X
30	X	X	88	X		240		X
32	X	X	90	X	X	250		X
33	X	X	92		X	260		
34	X	X	95	X	X	270		
35	X	X	98			280		
36	X	X				300		

ÖVRIGA DIMENSIONER MOT FÖRFRÅGAN !

FÖRP.	500 ST	200 ST	100 ST	50 ST	1 ST
	3-	16-	36-	85-	90-



SPÄRRYTTARE FÖR AXEL

RS DIN 6799

OBEH - FZB

C:A PRIS/100 ST								
DIM	OBEH	FZB	DIM	OBEH	FZB	DIM	OBEH	FZB
0.8			4	X		10	X	
1.2			5	X		12	X	
1.5	X		6	X		15	X	
1.9			7	X		19		
2.3	X		8	X		24		
3.2	X		9	X		30		

FÖRP.	1000 ST	200 ST
	0,8-	12-

BESTÄLLNINGSEXEMPEL: 15000010 - SGA 10x1

BESTÄLLNINGSEXEMPEL: 15010010 - SGH 10x1

BESTÄLLNINGSEXEMPEL: 15050003 - RS 3,2x0,6

SWEBOLT AB

TEL 08-555 975 00 FAX 08-583 581 82

ARTIKELLISTA
2013-2014
PASSBRICKA / SHIMS
PB DIN 988



C:A PRIS/100 ST							
DIM	STÅL	DIM	STÅL	DIM	STÅL	DIM	STÅL
4x8x0.5	X	14x20x0.3		25x35x0.2		40x50x0.1	X
5x10x0.3		14x20x0.5		25x35x0.3	X	40x50x0.2	
5x10x0.5	X	14x20x1.0	X	25x35x0.5	X	40x50x0.3	
5x10x1.0	X	14x20x1.5	X	25x35x1.0	X	40x50x0.5	X
6x12x0.1	X	15x21x0.1		25x35x2.0	X	40x50x1.0	X
6x12x0.2		15x21x0.2		25x36x2.0	X	40x50x1.5	
6x12x0.3	X	15x21x0.3	X	25x38x2.0	X	40x50x2.0	
6x12x0.5	X	15x21x0.5	X	28x40x0.1		40x50x2.5	X
6x12x1.0	X	15x21x1.0	X	28x40x0.2		42x52x0.5	
6x12x1.2	X	15x21x1.5	X	28x40x0.3		42x52x1.0	X
7x13x0.1	X	16x22x0.1	X	28x40x0.5	X	42x52x1.2	
7x13x0.2	X	16x22x0.2	X	28x40x1.0	X	42x52x1.5	X
7x13x0.3	X	16x22x0.3		28x40x1.2		42x52x2.0	
7x13x0.5		16x22x0.5	X	28x40x1.5		45x55x0.3	X
7x13x1.0		16x22x1.0	X	28x40x2.0	X	45x55x0.5	X
8x14x0.1	X	16x22x1.2		30x42x0.1		45x55x1.0	X
8x14x0.2	X	16x22x1.5	X	30x42x0.2		45x55x1.5	
8x14x0.3		17x24x0.1		30x42x0.3		45x55x3.0	X
8x14x0.5	X	17x24x0.2		30x42x0.5	X	50x62x0.1	X
8x14x1.0	X	17x24x0.3		30x42x1.0	X	50x62x0.2	X
8x14x1.2	X	17x24x0.5	X	30x42x1.2		50x62x0.3	
9x15x0.1		17x24x1.0	X	30x42x1.5		50x62x0.5	
9x15x0.2		17x24x1.2		30x42x2.0	X	50x62x1.0	X
9x15x0.3		17x24x1.5	X	30x42x2.5	X	50x62x1.5	
9x15x0.5		18x25x0.1		32x45x0.2		50x62x2.0	
9x15x1.0		18x25x0.2		32x45x0.3		50x62x3.0	X
9x15x1.2	X	18x25x0.3		32x45x0.5		50x63x3.0	X
10x16x0.1	X	18x25x0.5	X	32x45x1.0	X	50x65x3.0	X
10x16x0.2	X	18x25x1.0		32x45x1.2		52x65x1.0	X
10x16x0.3	X	18x25x1.2		32x45x1.5		52x65x3.0	X
10x16x0.5	X	18x25x1.5	X	32x45x2.0		55x68x1.0	
10x16x1.0	X	20x28x0.1	X	32x45x2.5	X	55x68x2.0	
10x16x1.2	X	20x28x0.2		35x45x0.2	X	55x68x3.0	X
10x16x1.5	X	20x28x0.3		35x45x0.5		56x72x1.0	X
10x16x2.0		20x28x0.5	X	35x45x1.0		56x72x3.0	X
11x17x0.5	X	20x28x1.0	X	35x45x1.2		60x75x3.0	X
11x17x1.0	X	20x28x1.5		35x45x1.5		63x80x1.0	X
11x17x1.5	X	20x28x2.0	X	35x45x2.0		63x80x2.0	
12x18x0.1	X	22x30x0.1		35x45x2.5	X	63x80x3.0	X
12x18x0.2	X	22x30x0.2		36x45x0.1	X	65x85x1.0	X
12x18x0.3	X	22x30x0.3		36x45x0.2		65x85x2.0	X
12x18x0.5	X	22x30x0.5	X	35x45x0.3		65x85x3.5	X
12x18x1.0	X	22x30x1.0		36x45x0.5	X	68x85x3.5	X
12x18x1.2	X	22x30x1.2		36x45x1.0	X	70x90x3.5	X
12x18x1.5	X	22x30x1.5		36x45x1.2		75x90x3.5	X
13x19x0.1		22x30x2.0	X	36x45x1.5		75x95x0.3	X
13x19x0.2		22x32x0.1		36x45x2.5	X	75x95x1.0	X
13x19x0.3		22x32x0.2		37x47x0.1	X	75x95x3.5	X
13x19x0.5		22x32x0.5		37x47x0.2	X	80x100x0.3	X
13x19x1.0		22x32x1.0	X	35x47x0.3		80x100x0.5	X
13x19x1.2		22x32x1.2		37x47x0.5		80x100x3.5	X
13x19x1.5	X	22x32x1.5		37x47x1.0		90x110x3.5	X
14x20x0.2		22x32x2.0	X	37x47x1.2		95x115x0.5	X

BESTÄLLNINGSEXEMPEL: 15100111705 - PB 11X17X0,5

SWEBOLT AB

TEL 08-555 975 00 FAX 08-583 581 82

5:2



ARTIKELLISTA

2013-2014
SPÄNNBRICKA

SPB DIN 6796

MEKANISKT FÖRZINKAD

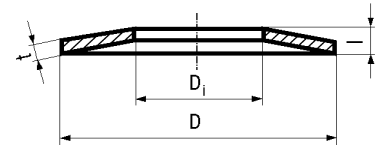

C:A PRIS/100 ST						
DIM	Di	D	l max	l min	t	FZM
M2	2.2	5	0.6	0.5	0.4	
M2.5	2.7	6	0.72	0.61	0.5	X
M3	3.2	7	0.85	0.72	0.6	X
M4	4.3	9	1.3	1.12	1	X
M5	5.3	11	1.55	1.35	1.2	X
M6	6.4	14	2	1.7	1.5	X
M8	8.4	18	2.6	2.24	2	X
M10	10.5	23	3.2	2.8	2.5	X
M12	13	29	3.95	3.43	3	X
M14	15	35	4.65	4.04	3.5	X
M16	17	39	5.25	4.58	4	X
M20	21	45	6.4	5.6	5	X
M24	25	56	7.75	6.77	6	
M27	28	60	8.35	7.3	6.5	
M30	31	70	9.2	8	7	

BESTÄLLNINGSEXEMPEL: 15251120 - SPB M12 FZM

FÖRP	FZG
1000 ST	M2.5-
500 ST	M4-
200 ST	M6-
100 ST	M16-

ÖVRIGA DIMENSIONER MOT FÖRGRÅGAN !

SWEBOLT AB

TEL 08-555 975 00 FAX 08-583 581 82

ARTIKELLISTA

2013-2014
LÅSRINGAR

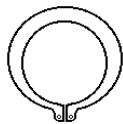

SGA DIN 471 / SGH DIN 472
ROSTFRI A2

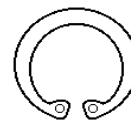

C:A PRIS / 100 ST					
DIM	SGA	SGH	DIM	SGA	SGH
3	X		32	X	X
4	X		33	X	X
5	X		34	X	X
6	X		35	X	X
7	X		36	X	X
8	X	X	37	X	X
9	X	X	38	X	X
10	X	X	39	X	X
11	X	X	40	X	X
12	X	X	42	X	X
13	X	X	44	X	X
14	X	X	45	X	X
15	X	X	47	X	X
16	X	X	48	X	X
17	X	X	50	X	X
18	X	X	52	X	X
19	X	X	55	X	X
20	X	X	60	X	X
21	X	X	62	X	X
22	X	X	65	X	X
23	X	X	68	X	X
24	X	X	70	X	X
25	X	X	75	X	X
26	X	X	80	X	X
27	X	X	85	X	X
28	X	X	90	X	X
29	X	X	95	X	X
30	X	X	100	X	X

ÖVRIGA DIMENSIONER MOT FÖRFRÅGAN !

FÖRP.	200 ST	100 ST	50 ST	25 ST	10 ST
	3-	42-	50-	62-	75-

BESTÄLLNINGSEXEMPEL: 25000010 - SGA 10 A2

BESTÄLLNINGSEXEMPEL: 25010010 - SGH 10 A2

SWEBOLT AB

TEL 08-555 975 00 FAX 08-583 581 82

ARTIKELLISTA
2013-2014
SPÅRRYTTARE FÖR AXEL
RS DIN 6799
ROSTFRI Ws 1.4122



C:A PRIS/100 ST	
DIM	RS
1.2	X
1.5	X
1.9	X
2.3	X
3.2	X
4	X
5	X
6	X
7	X
8	X
9	X
10	X
12	X
15	X
19	X
24	X

ÖVRIGA DIMENSIONER MOT FÖRFRÅGAN !

FÖRP.	200 ST	100 ST	50 ST	25 ST	10 ST
	1.2-	4-			

SWEBOLT AB
TEL 08-555 975 00 FAX 08-583 581 82

ARTIKELLISTA
2013-2014
SPÄNNBRICKA
SPB DIN 6796
ROSTFRI A2

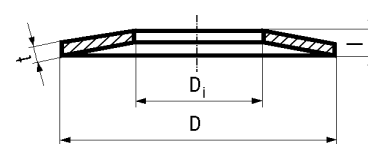











C:A PRIS/100 ST						
DIM	Di	D	l max	l min	t	A2
M2	2.2	5	0.6	0.5	0.4	
M2.5	2.7	6	0.72	0.61	0.5	
M3	3.2	7	0.85	0.72	0.6	X
M4	4.3	9	1.3	1.12	1	X
M5	5.3	11	1.55	1.35	1.2	X
M6	6.4	14	2	1.7	1.5	X
M8	8.4	18	2.6	2.24	2	X
M10	10.5	23	3.2	2.8	2.5	X
M12	13	29	3.95	3.43	3	X
M14	15	35	4.65	4.04	3.5	
M16	17	39	5.25	4.58	4	
M20	21	45	6.4	5.6	5	
M24	25	56	7.75	6.77	6	
M27	28	60	8.35	7.3	6.5	
M30	31	70	9.2	8	7	

BESTÄLLNINGSEXEMPEL: 25250100 - SPB M10 A2

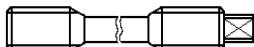
FÖRP	A2
1000 ST	
500 ST	M5-
200 ST	M6-
100 ST	M16-

ÖVRIGA DIMENSIONER MOT FÖRGRÅGAN !

SWEBOLT AB
TEL 08-555 975 00 FAX 08-583 581 82

- 1 - 	- 2 - 	- 3 - 	- 4 - 
- 5 - 	- 6 - 	- 7 - 	- 8 - 
- 9 - 	- 10 - 	- 11 - 	- 12 - 
- 13 -	- 14 -	- 15 -	- 16 -
- 17 -	- 18 -	- 19 -	- 20 -
- 21 -	- 22 -	- 23 -	- 24 -
- 25 -	- 26 -	- 27 -	- 28 -
- 29 -	- 30 -	- 31 -	- 32 -

SWEBOLT AB

TEL. 08-584 909 60 FAX. 08-583 581 82

PRODUKTER I STÅL

1	16000	MPS, PINNSKRUV		SS1460	5.8	OBEH	6:7
1	16001	MPS, PINNSKRUV		SS1460	5.8	FZB	6:7
1	16002	MPS, PINNSKRUV		SS1460	5.8	FZV	6:7
1	16003	MPS, PINNSKRUV		SS1460	8.8	OBEH	6:8
1	16004	MPS, PINNSKRUV		SS1460	8.8	FZB	6:8
1	16005	MPS, PINNSKRUV		SS1460	10.9	OBEH	6:8
1	16010	UPS, PINNSKRUV, UNC		SS1948	5.8	OBEH	6:20
1	16011	UPS, PINNSKRUV, UNC		SS1948	5.8	FZB	6:20
1	16013	UPS, PINNSKRUV, UNC		SS1948	8.8	OBEH	6:21
1	16014	UPS, PINNSKRUV, UNC		SS1948	8.8	FZB	6:21
2	16030	MPS, PINNSKRUV		938	5.8	OBEH	6:14
2	16031	MPS, PINNSKRUV		938	5.8	FZB	6:14
2	16032	MPS, PINNSKRUV		938	8.8	OBEH	6:15
2	16033	MPS, PINNSKRUV		938	8.8	FZB	6:15
2	16034	MPS, PINNSKRUV		938	10.9	OBEH	6:16
2	16035	MPS, PINNSKRUV		939	5.8	OBEH	6:16
2	16036	MPS, PINNSKRUV		939	5.8	FZB	6:17
2	16037	MPS, PINNSKRUV		939	8.8	OBEH	6:18
2	16038	MPS, PINNSKRUV		939	8.8	FZB	6:18
2	16039	MPS, PINNSKRUV		939	10.9	OBEH	6:19
3	16050	MHGS, HELGÄNGAD STÅNG		976	4.6	OBEH	6:1
3	16051	MHGS, HELGÄNGAD STÅNG		976	4.6	FZB	6:1
3	16052	MHGS, HELGÄNGAD STÅNG		976	4.6	FZV	6:1
3	16067	MHGS, HELGÄNGAD STÅNG 27J		976	5.6	OBEH	
3	16668	MHGS, HELGÄNGAD STÅNG 27J		976	5.6	FZB	
3	16669	MHGS, HELGÄNGAD STÅNG 27J		976	5.6	FZV	
3	16053	MHGS, HELGÄNGAD STÅNG		976	5.8	OBEH	6:2
3	16054	MHGS, HELGÄNGAD STÅNG		976	5.8	FZB	6:2
3	16055	MHGS, HELGÄNGAD STÅNG		976	5.8	FZV	6:2
3	16056	MHGS, HELGÄNGAD STÅNG 27J		976	8.8	OBEH	6:3
3	16057	MHGS, HELGÄNGAD STÅNG 27J		976	8.8	FZB	6:3
3	16058	MHGS, HELGÄNGAD STÅNG 27J		976	8.8	FZV	6:3
3	16064	MHGS, HELGÄNGAD STÅNG		976	460NL	OBEH	
3	16065	MHGS, HELGÄNGAD STÅNG		976	460NL	FZB	
3	16066	MHGS, HELGÄNGAD STÅNG		976	460NL	FZV	
3	16060	UHGS, HELGÄNGAD STÅNG		UNC	4.6	OBEH	6:1
3	16061	UHGS, HELGÄNGAD STÅNG		UNC	4.6	FZB	6:1
3	16070	MHGS, HELGÄNGAD STÅNG		976	10.9	OBEH	6:3
3	16073	MHGS, HELGÄNGAD STÅNG		976	12.9	OBEH	6:3
3	16080	MHGS, UNDERSKUREN			5.8	OBEH	6:2
3	16090	VMHGS, VÄNSTERGÄNGA			8.8	OBEH	6:3
4	16075	TRHGS, HELGÄNGAD STÅNG	TRAPETSGÄNGA		5.8	OBEH	6:4

SWEBOLT AB

TEL. 08-584 909 60 FAX. 08-583 581 82

BILD	ART.GR.	BENÄMNING	DIN	ISO	KVAL	YTBEH	SIDA
5	16200	MHPS, HELGÄNGAD PINNSKRUV			4.6	OBEH	6:9
5	16201	MHPS, HELGÄNGAD PINNSKRUV			4.6	FZB	6:9
5	16202	MHPS, HELGÄNGAD PINNSKRUV			4.6	FZV	6:9
5	16203	UHPS, HELGÄNGAD PINNSKRUV	UNC		4.6	OBEH	6:22
5	16204	UHPS, HELGÄNGAD PINNSKRUV	UNC		4.6	FZB	6:22
5	16210	MHPS, HELGÄNGAD PINNSKRUV			5.8	OBEH	6:10
5	16211	MHPS, HELGÄNGAD PINNSKRUV			5.8	FZB	6:10
5	16212	MHPS, HELGÄNGAD PINNSKRUV			5.8	FZV	6:10
5	16220	MHPS, HELGÄNGAD PINNSKRUV			8.8	OBEH	6:11
5	16221	MHPS, HELGÄNGAD PINNSKRUV			8.8	FZB	6:11
5	16222	MHPS, HELGÄNGAD PINNSKRUV			8.8	FZV	6:11
5	16240	MHPS, HELGÄNGAD PINNSKRUV			10.9	OBEH	6:23
5	16241	MHPS, HELGÄNGAD PINNSKRUV			10.9	FZB	6:23
5	16110	MHGS, VARMHÅLLFAST GÄNGSTÅNG		976	A193 B7	OBEH	6:5
5	16112	MHGS, VARMHÅLLFAST GÄNGSTÅNG		976	A193 B7	FZV	6:5
5	16120	UHGS, VARMHÅLLFAST GÄNGSTÅNG	UNC		A193 B7	OBEH	6:5
5	16122	UHGS, VARMHÅLLFAST GÄNGSTÅNG	UNC		A193 B7	FZV	6:5
5	16500	MHPS, PINNSKRUV	976		CK35	OBEH	
5	16501	MHPS, PINNSKRUV	976		CK35	FZB	
5	16502	MHPS, PINNSKRUV	976		CK35	FZV	
5	16505	MHPS, PINNSKRUV	976		24CrMo5	OBEH	
5	16506	MHPS, PINNSKRUV	976		24CrMo5	FZB	
5	16507	MHPS, PINNSKRUV	976		24CrMo5	FZV	
5	16510	MHPS, PINNSKRUV	976		21CrMoV57	OBEH	
5	16511	MHPS, PINNSKRUV	976		21CrMoV57	FZB	
5	16512	MHPS, PINNSKRUV	976		21CrMoV57	FZV	
5	16515	MHPS, PINNSKRUV	976		40CrMoV4	OBEH	
5	16516	MHPS, PINNSKRUV	976		40CrMoV4	FZB	
5	16517	MHPS, PINNSKRUV	976		40CrMoV4	FZV	
5	16520	MHPS, PINNSKRUV	976		x22CrMoV121	OBEH	
5	16521	MHPS, PINNSKRUV	976		x22CrMoV121	FZB	
5	16522	MHPS, PINNSKRUV	976		x22CrMoV121	FZV	
5	16525	MHPS, PINNSKRUV	976		A193 B7	OBEH	
5	16526	MHPS, PINNSKRUV	976		A193 B7	FZB	
5	16527	MHPS, PINNSKRUV	976		A193 B7	FZV	
5	16530	MHPS, PINNSKRUV	976		A193 B8	OBEH	
5	16531	MHPS, PINNSKRUV	976		A193 B8	FZB	
5	16532	MHPS, PINNSKRUV	976		A193 B8	FZV	
5	16535	MHPS, PINNSKRUV	976		A193 B8M	OBEH	
5	16536	MHPS, PINNSKRUV	976		A193 B8M	FZB	
5	16537	MHPS, PINNSKRUV	976		A193 B8M	FZV	
5	16540	MHPS, PINNSKRUV	976		A193 B8MX	OBEH	
5	16541	MHPS, PINNSKRUV	976		A193 B8MX	FZB	

SWEBOLT AB

TEL. 08-584 909 60 FAX. 08-583 581 82

BILD	ART.GR.	BENÄMNING	DIN	ISO	KVAL	YTBEH	SIDA
5	16542	MHPS, PINNSKRUV	976		A193 B8MX	FZV	
5	16545	MHPS, PINNSKRUV	976		A320 L7	OBEH	
5	16546	MHPS, PINNSKRUV	976		A320 L7	FZB	
5	16547	MHPS, PINNSKRUV	976		A320 L7	FZV	
5	16557	MHPS, PINNSKRUV	976		A370 L7	OBEH	
5	16558	MHPS, PINNSKRUV	976		A370 L7	FZV	
5	16550	MHPS, PINNSKRUV	976		42CrMo5	OBEH	
5	16551	MHPS, PINNSKRUV	976		42CrMo5	FZB	
5	16552	MHPS, PINNSKRUV	976		42CrMo5	FZV	
5	16555	MHPS, PINNSKRUV	976		DUPLEX		
5	16556	MHPS, PINNSKRUV	976		SUPER DUPLEX		
5	16600	UHPS, PINNSKRUV UNC	976		CK35	OBEH	
5	16601	UHPS, PINNSKRUV UNC	976		CK35	FZB	
5	16602	UHPS, PINNSKRUV UNC	976		CK35	FZV	
5	16605	UHPS, PINNSKRUV UNC	976		24CrMo5	OBEH	
5	16606	UHPS, PINNSKRUV UNC	976		24CrMo5	FZB	
5	16607	UHPS, PINNSKRUV UNC	976		24CrMo5	FZV	
5	16610	UHPS, PINNSKRUV UNC	976		21CrMoV57	OBEH	
5	16611	UHPS, PINNSKRUV UNC	976		21CrMoV57	FZB	
5	16612	UHPS, PINNSKRUV UNC	976		21CrMoV57	FZV	
5	16615	UHPS, PINNSKRUV UNC	976		40CrMoV47	OBEH	
5	16616	UHPS, PINNSKRUV UNC	976		40CrMoV47	FZB	
5	16617	UHPS, PINNSKRUV UNC	976		40CrMoV47	FZV	
5	16620	UHPS, PINNSKRUV UNC	976		x22CrMoV121	OBEH	
5	16621	UHPS, PINNSKRUV UNC	976		x22CrMoV121	FZB	
5	16622	UHPS, PINNSKRUV UNC	976		x22CrMoV121	FZV	
5	16625	UHPS, PINNSKRUV UNC	976		A193 B7	OBEH	
5	16626	UHPS, PINNSKRUV UNC	976		A193 B7	FZB	
5	16627	UHPS, PINNSKRUV UNC	976		A193 B7	FZV	
5	16630	UHPS, PINNSKRUV UNC	976		A193 B8	OBEH	
5	16631	UHPS, PINNSKRUV UNC	976		A193 B8	FZB	
5	16632	UHPS, PINNSKRUV UNC	976		A193 B8	FZV	
5	16635	UHPS, PINNSKRUV UNC	976		A193 B8M	OBEH	
5	16636	UHPS, PINNSKRUV UNC	976		A193 B8M	FZB	
5	16637	UHPS, PINNSKRUV UNC	976		A193 B8M	FZV	
5	16640	UHPS, PINNSKRUV UNC	976		A193 B8MX	OBEH	
5	16641	UHPS, PINNSKRUV UNC	976		A193 B8MX	FZB	
5	16642	UHPS, PINNSKRUV UNC	976		A193 B8MX	FZV	
5	16645	UHPS, PINNSKRUV UNC	976		A320 L7	OBEH	
5	16646	UHPS, PINNSKRUV UNC	976		A320 L7	FZB	
5	16647	UHPS, PINNSKRUV UNC	976		A320 L7	FZV	

SWEBOLT AB

TEL. 08-584 909 60 FAX. 08-583 581 82

BILD	ART.GR.	BENÄMNING	DIN	ISO	KVAL	YTBEH	SIDA
5	16657	UHPS, PINNSKRUV UNC	976		A370 L7	OBEH	
5	16658	UHPS, PINNSKRUV UNC	976		A370 L7	FZV	
5	16650	UHPS, PINNSKRUV UNC	976		42CrMo5	OBEH	
5	16651	UHPS, PINNSKRUV UNC	976		42CrMo5	FZB	
5	16652	UHPS, PINNSKRUV UNC	976		42CrMo5	FZV	
5	16655	UHPS, PINNSKRUV UNC	976		DUPLEX		
5	16656	UHPS, PINNSKRUV UNC	976		SUPER DUPLEX		
6	16660	VPS, PINNSKRUV m. MIDJA	2510L		CK35	OBEH	
6	16661	VPS, PINNSKRUV m. MIDJA	2510L		CK35	FZB	
6	16662	VPS, PINNSKRUV m. MIDJA	2510L		CK35	FZV	
6	16665	VPS, PINNSKRUV m. MIDJA	2510L		24CrMo5	OBEH	
6	16666	VPS, PINNSKRUV m. MIDJA	2510L		24CrMo5	FZB	
6	16667	VPS, PINNSKRUV m. MIDJA	2510L		24CrMo5	FZV	
6	16670	VPS, PINNSKRUV m. MIDJA	2510L		21CrMoV57	OBEH	
6	16671	VPS, PINNSKRUV m. MIDJA	2510L		21CrMoV57	FZB	
6	16672	VPS, PINNSKRUV m. MIDJA	2510L		21CrMoV57	FZV	
6	16675	VPS, PINNSKRUV m. MIDJA	2510L		x22CrMoV121	OBEH	
6	16676	VPS, PINNSKRUV m. MIDJA	2510L		x22CrMoV121	FZB	
6	16677	VPS, PINNSKRUV m. MIDJA	2510L		x22CrMoV121	FZV	
6	16680	VPS, PINNSKRUV m. MIDJA	2510L		42CrMo4	OBEH	
6	16681	VPS, PINNSKRUV m. MIDJA	2510L		42CrMo4	FZB	
6	16682	VPS, PINNSKRUV m. MIDJA	2510L		42CrMo4	FZV	
6	16695	UVPS, PINNSKRUV m. MIDJA UNC	2510L		CK35	OBEH	
6	16696	UVPS, PINNSKRUV m. MIDJA UNC	2510L		CK35	FZB	
6	16697	UVPS, PINNSKRUV m. MIDJA UNC	2510L		CK35	FZV	
6	16695	UVPS, PINNSKRUV m. MIDJA UNC	2510L		CK35	OBEH	
6	16696	UVPS, PINNSKRUV m. MIDJA UNC	2510L		CK35	FZB	
6	16697	UVPS, PINNSKRUV m. MIDJA UNC	2510L		CK35	FZV	
6	16685	UVPS, PINNSKRUV m. MIDJA UNC	2510L		24CrMo5	OBEH	
6	16686	UVPS, PINNSKRUV m. MIDJA UNC	2510L		24CrMo5	FZB	
6	16687	UVPS, PINNSKRUV m. MIDJA UNC	2510L		24CrMo5	FZV	
6	16690	UVPS, PINNSKRUV m. MIDJA UNC	2510L		21CrMoV57	OBEH	
6	16691	UVPS, PINNSKRUV m. MIDJA UNC	2510L		21CrMoV57	FZB	
6	16692	UVPS, PINNSKRUV m. MIDJA UNC	2510L		21CrMoV57	FZV	
7	16130	VHM6M, VARMHÅLLF. MUTTER	2510NF	24CrMo5		OBEH	6:5
7	16135	M6M2H, VARMHÅLLF. MUTTER	934	ASTM.A 194 Gr 2H		OBEH	6:5
7	16136	U6M2H, VARMHÅLLF. MUTTER	934	ASTM.A 194 Gr 2H		OBEH	6:5
7	16137	U6M2H, VARMHÅLLF. MUTTER	934	ASTM.A 194 Gr 2H		FZV	6:5
7	16138	U6M2H, VARMHÅLLF. MUTTER	934	ASTM.A 194 B7		OBEH	6:5
7	16139	U6M2H, VARMHÅLLF. MUTTER	934	ASTM.A 194 B7		FZV	6:5

SWEBOLT AB

TEL. 08-584 909 60 FAX. 08-583 581 82

<u>BILD</u>	<u>ART.GR.</u>	<u>BENÄMNING</u>	<u>DIN</u>	<u>ISO</u>	<u>KVAL</u>	<u>YTBEH</u>	<u>SIDA</u>
8	16150	TRM, TRAPETSMUTTER, RUND				OBEH	6:4
	16155	TR6M, TRAPETSMUTTER, 6-KANT				OBEH	6:4
8	16160	TRM, TRAPETSMUTTER, RUND				BRONS Cu4	6:4
9	16300	ANKARPINNE / SNEDKAPAD			4.6	OBEH	6:12
9	16301	ANKARPINNE / SNEDKAPAD			4.6	FZB	6:12
9	16305	ANKARPINNE / SNEDKAPAD			5.8	OBEH	6:12
9	16306	ANKARPINNE / SNEDKAPAD			5.8	FZB	6:12
9	16307	ANKARPINNE / SNEDKAPAD			5.8	FZV	6:12
9	16310	ANKARPINNE / SNEDKAPAD			8.8	OBEH	6:12
9	16311	ANKARPINNE / SNEDKAPAD			8.8	FZB	6:12
9	16312	ANKARPINNE / SNEDKAPAD			8.8	FZV	6:12
10	16280	SP, SVETSPINNBULT			5.8	OBEH	6:13

SWEBOLT AB

TEL. 08-584 909 60 FAX. 08-583 581 82

ROSTFRITT / SYRAFAST

1	26000	MPS, PINNSKRUV	SS1460	A2	6:47
1	26001	MPS, PINNSKRUV	SS1460	A4	6:47
1	26010	UPS, PINNSKRUV, UNC	SS1948	A2	6:48
1	26011	UPS, PINNSKRUV, UNC	SS1948	A4	6:48
2	26030	MPS, PINNSKRUV	938	A2	6:45
2	26031	MPS, PINNSKRUV	938	A4	6:43
2	26035	MPS, PINNSKRUV	939	A2	6:46
2	26036	MPS, PINNSKRUV	939	A4	6:44
3	26050	MHGS, HELGÄNGAD STÅNG	976	A2	6:40
3	26051	MHGS, HELGÄNGAD STÅNG	976	A4	6:40
3	26052	MHGS, HELGÄNGAD STÅNG	976	A4 BUMAX	
3	26060	UHGS, HELGÄNGAD STÅNG	UNC	A2	6:40
3	26061	UHGS, HELGÄNGAD STÅNG	UNC	A4	6:40
5	26100	MHPS, HELGÄNGAD PINNSKRUV	976	A2	6:41
5	26101	MHPS, HELGÄNGAD PINNSKRUV	976	A4	6:41
9	26300	ANKARPINNE / SNEDKAPAD		A2	6:42
9	26301	ANKARPINNE / SNEDKAPAD		A4	6:42

MÄSSING

2	36000	MPS, PINNSKRUV	SS1460		6:60
2	36030	MPS, PINNSKRUV	938		6:61
2	36035	MPS, PINNSKRUV	939		6:61
3	36050	MHGS, HELGÄNGAD STÅNG	976		6:70

POLYAMID

3	46050	MHGS, HELGÄNGAD STÅNG			6:90
---	-------	-----------------------	--	--	------

ALUMINIUM

3	56050	MHGS, HELGÄNGAD STÅNG	975		6:80
---	-------	-----------------------	-----	--	------

ARTIKELLISTA

2013-2014

HELGÄNGAD STÅNG

MHGS DIN 976 4.6

UHGS / UNC

OBEHANDLAD - BLANKFÖRZINKAD



C:A PRIS/100 ST				
DIM	4.6 OBEH		4.6 FZB	
	1M	2M	1M	2M
M3			X	
M4			X	
M5	X		X	X
M6	X		X	X
M8	X	X	X	X
M10	X	X	X	X
M12	X	X	X	X
M14	X	X	X	X
M16	X	X	X	X
M18	X		X	X
M20	X	X	X	X
M22	X		X	X
M24	X	X	X	X
M27	X	X	X	X
M30	X	X	X	X
M33	X		X	
M36	X		X	X
M39			X	
M42	X		X	
M45	X		X	
M48	X			
M52	X			

UHGS 4.6 BLANKFÖRZINKAD FZB 1M

C:A PRIS/100 ST		
DIM	OBEH	FZB
1/4"		X
5/16"		X
3/8"		X
1/2"		X
5/8"		X
3/4"		X
7/8"		X
1"		X

ÖVRIGA DIMENSIONER OCH LÄNGDER MOT FÖRFRÅGAN !

BESTÄLLNINGSEXEMPEL: 16050081000 - MHGS M8 4.6 OBEH

BESTÄLLNINGSEXEMPEL: 16050082000 - MHGS M8x2000 4.6 OBEH

BESTÄLLNINGSEXEMPEL: 16051081000 - MHGS M8 4.6 FZB

BESTÄLLNINGSEXEMPEL: 16051082000 - MHGS M8x2000 4.6 FZB

BESTÄLLNINGSEXEMPEL: 160612541000 - UHGS 1" 4.6 FZB

SWEBOLT AB

TEL 08 - 555 975 00 FAX 08 - 583 581 82

ARTIKELLISTA
2013-2014
HELGÄNGAD STÅNG
MHGS DIN 976 5.8 / S460NL
OBEH - FZB - FZV



C:A PRIS/100 ST					
DIM	ST52.3 OBEH		ST52.3 FZB	ST 52.3 FZV	
	1M	2M	2M	1M	2M
M3					
M4					
M5					
M6					
M8			X		
M10		X	X	X	X
M12		X	X	X	X
M14					
M16		X	X	X	X
M18					
M20		X	X	X	X
M22					
M24	X	X	X	X	X
M27		X		X	X
M30		X		X	X
M33					
M36				X	X
M39					
M42					
M45					
M48					
M52					

ÖVRIGA DIMENSIONER OCH LÄNGDER MOT FÖRFRÅGAN

BESTÄLLNINGSEXEMPEL: 16054102000 - MHGS M10X2000 ST52.3 FZB

BESTÄLLNINGSEXEMPEL: 16055161000 - MHGS M16 ST52.3 FZV

BESTÄLLNINGSEXEMPEL: 16055161500 - MHGS M16X1500 ST52.3 FZV

BESTÄLLNINGSEXEMPEL: 16055162000 - MHGS M16X2000 ST52.3 FZV

DIN 976 S460 NL

C:A PRIS/100 ST				
DIM	S460 NL OBEH		S460 NL FZV	
	1M	2M	1M	2M
M16	X	X	X	X
M20	X	X	X	X
M24	X	X	X	X
M27	X	X	X	X
M30	X	X	X	X
M33	X	X	X	X
M36	X	X	X	X
M42			X	

BESTÄLLNINGSEXEMPEL: 16064201000 - MHGS M20 S460NL

BESTÄLLNINGSEXEMPEL: 16064202000 - MHGS M20x2000 S460NL

BESTÄLLNINGSEXEMPEL: 16066201000 - MHGS M20 S460NL FZV

BESTÄLLNINGSEXEMPEL: 16064202000 - MHGS M20x2000 S460NL FZV

SWEBOLT AB

TEL 08 - 555 975 00 FAX 08 - 583 581 82

ARTIKELLISTA

2013-2014

HELGÄNGAD STÅNG

MHGS DIN 976 8.8 - 10.9 - 12.9

OBEH - FZB - FZV



C:A PRIS/100 ST						
DIM	8.8 OBEH		8.8 FZB		8.8 FZV	
	1M	2M	1M	2M	1M	2M
M3						
M4						
M5			X			
M6	X		X	X		
M8	X	X	X	X	X	
M10	X	X	X	X	X	X
M12	X	X	X	X	X	X
M14	X		X	X		
M16	X	X	X	X	X	X
M18	X	X	X	X		
M20	X	X	X	X	X	X
M22	X		X	X		
M24	X	X	X	X	X	X
M27	X		X	X	X	X
M30	X	X	X	X	X	X
M33	X		X	X	X	X
M36	X		X	X	X	X
M39			X		X	X
M42	X		X		X	X
M45	X		X		X	
M48	X		X		X	X
M52			X			

MHGS DIN 976 10.9 - 12.9

OBEH 1-METER

C:A PRIS/100 ST		
DIM	10.9	12.9
M5	X	X
M6	X	X
M8	X	X
M10	X	X
M12	X	X
M14	X	
M16	X	X
M20	X	X
M24	X	X
M27	X	
M30	X	X
M33		
M36	X	X
M39	X	
M42	X	

BESTÄLLNINGSEXEMPEL:

16056101000 - MHGS M10 8.8 OBEH
16056102000 - MHGS M10X2000 8.8 OBEH
16057101000 - MHGS M10 8.8 FZB
16057102000 - MHGS M10X2000 8.8 FZB
16058201000 - MHGS M20 8.8 FZV
16058202000 - MHGS M20X2000 8.8 FZV
16070201000 - MHGS M20 10.9
16073201000 - MHGS M20 12.9

ÖVRIGA DIMENSIONER OCH LÄNGDER MOT FÖRFRÅGAN !

SWEBOLT AB

TEL 08 - 555 975 00 FAX 08 - 583 581 82

ARTIKELLISTA

2013-2014

TRHGS HELGÄNGAD STÅNG DIN 976

TRAPETGÄNGA ST52.3 (5.8)



C:A PRIS/100 ST	
DIM	1m
TR 10x3	X
12x3	X
14x4	X
16x4	X
18x4	X
20x4	X
22x5	X
24x5	X
26x5	X
28x5	X
30x6	X
32x6	X
36x6	X
40x7	X
44x7	X
50x8	
60x9	X

TRM TRAPETSMUTTER STÅL - BRONS

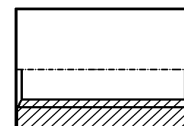

C:A PRIS/100 ST			
DIM	DIAM x LÄNGD	STÅL	BRONS
TR 10x3	22x15	X	
12x3	26x18	X	
14x4	30x21	X	
16x4	36x24	X	
18x4	40x27	X	
20x4	45x30	X	
22x5	45x33	X	
24x5	50x36	X	
26x5	50x39	X	
28x5	60x42	X	
30x6	60x45	X	
32x6	60x48	X	
36x6	75x54	X	
40x7	80x60	X	
44x7	80x66	X	
50x8	90x75	X	
60x9	100x90	X	

ÖVRIGA DIMENSIONER OCH LÄNGDER MOT FÖRFRÅGAN !

BESTÄLLNINGSEXEMPEL: 160751841000 - TRHGS 18X4X1000 ST52.3

BESTÄLLNINGSEXEMPEL: 16150184 - TRM 18X4 STÅL

SWEBOLT AB

TEL 08 - 555 975 00 FAX 08 - 583 581 82

ARTIKELLISTA

2013-2014

GÄNGSTÅNG MATERIAL ASTM A 193 B7 MHGS VARMHÅLLFAST



PRIS/100 ST	
DIM	OBEH
M10x2M	X
M12x2M	X
M16x2M	X
M20x2M	X
M24x2M	X
M27x2M	X
M30x2M	X

INKL CERT 3.1B

FRÅN DESSA KAN VI KAPA I OLIKA LÄNGDER, ALLT ENLIGT FÖRFRÅGAN.

VARMHÅLLFAST MUTTER VHM6M DIN 2510 MATERIAL 24CrMo5

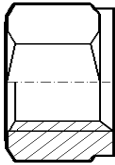

PRIS/100 ST			
DIM	NV	Höjd	OBEH
M12	22	12	X
M16	27	16	X
M20	32	20	X
M24	36	24	X
M27	41	27	X
M30	46	30	X
M33	50	33	X
M36	55	36	X
M39	60	39	X

BESTÄLLNINGSEXEMPEL: 16130120 - VHM6M M12 24CrMo5

M6M2H DIN 934 MATERIAL ASTM A 194 Gr2H

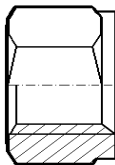

PRIS/100 ST			
DIM	NV	Höjd	OBEH
M12	19	12	X
M16	24	16	X
M20	30	20	X
M24	36	24	X
M27	41	27	X
M30	46	30	X
M36	55	36	X

ÖVRIGA DIMENSIONER OCH LÄNGDER MOT FRÖFRÅGAN !

FÖRP	OBEH.
100 ST	12-
50 ST	16-
25 ST	24-
10 ST	30-

SWEBOLT AB

TEL 08 - 555 975 00 FAX 08 - 583 581 82

ARTIKELLISTA

2013-2014

HELGÄNGAD PINNE MHPS ST52.3 (5.8)

LÄNGDTOLERANS $\pm 2\text{mm}$

VARMFÖRZINKAD



KALLFÖRZINKADE ÄNDAR VID KAPNING AV GÄNGSTÅNG

C:A PRIS/100 ST							
DIM	M8	M10	M12	M16	M20	M24	M30
80	X	X	X	X	X	X	X
90	X	X	X	X	X	X	X
100	X	X	X	X	X	X	X
110	X	X	X	X	X	X	X
120	X	X	X	X	X	X	X
130	X	X	X	X	X	X	X
140	X	X	X	X	X	X	X
150	X	X	X	X	X	X	X
160	X	X	X	X	X	X	X
190	X	X	X	X	X	X	X
210	X	X	X	X	X	X	X
212	X	X	X	X	X	X	X
230	X	X	X	X	X	X	X
240	X	X	X	X	X	X	X
250	X	X	X	X	X	X	X
270	X	X	X	X	X	X	X
285	X	X	X	X	X	X	X
300	X	X	X	X	X	X	X
310	X	X	X	X	X	X	X
320	X	X	X	X	X	X	X
370	X	X	X	X	X	X	X
400	X	X	X	X	X	X	X
470	X	X	X	X	X	X	X
570	X	X	X	X	X	X	X
585	X	X	X	X	X	X	X
625	X	X	X	X	X	X	X
785	X	X	X	X	X	X	X

ÖVRIGA DIMENSIONER OCH LÄNGDER MOT FÖRFRÅGAN !

STARTKOSTNAD 150 SEK FÖR ORDER UNDER 1000 SEK.

SWEBOLT AB

TEL 08 - 555 975 00 FAX 08 - 583 581 82

ARTIKELLISTA

2013-2014

HELGÄNGAD PINNE MHPS 8.8

LÄNGDTOLERANS ±2mm

VARMFÖRZINKAD

KALLFÖRZINKADE ÄNDAR



C:A PRIS/100 ST							
DIM	M10	M12	M16	M20	M24	M27	M30
80	X	X	X	X	X	X	X
90	X	X	X	X	X	X	X
100	X	X	X	X	X	X	X
110	X	X	X	X	X	X	X
120	X	X	X	X	X	X	X
130	X	X	X	X	X	X	X
140	X	X	X	X	X	X	X
150	X	X	X	X	X	X	X
160	X	X	X	X	X	X	X
180	X	X	X	X	X	X	X
200	X	X	X	X	X	X	X
220	X	X	X	X	X	X	X
230	X	X	X	X	X	X	X
240	X	X	X	X	X	X	X
250	X	X	X	X	X	X	X
260	X	X	X	X	X	X	X
280	X	X	X	X	X	X	X
300	X	X	X	X	X	X	X
320	X	X	X	X	X	X	X
330	X	X	X	X	X	X	X
340	X	X	X	X	X	X	X
380	X	X	X	X	X	X	X
400	X	X	X	X	X	X	X
450	X	X	X	X	X	X	X
500	X	X	X	X	X	X	X

ÖVRIGA DIMENSEIONER OCH LÄNGDER MOT FÖRFRÅGAN !

STARTKOSTNAD 150 SEK FÖR ORDER UNDER 1000 SEK.

SWEBOLT AB

TEL 08 - 555 975 00 FAX 08 - 583 581 82

ARTIKELLISTA
2013-2014
SNEDKAPAD PINNE
FÖR KEMANKARE
OBEH - FZB - FZV



C:A PRIS/100 ST								
KVALITET	4.6		5.8			8.8		
DIM	OBEH	FZB	OBEH	FZB	FZV	OBEH	FZB	FZV
8x110	X	X	X	X	X	X	X	X
10x130	X	X	X	X	X	X	X	X
12x160	X	X	X	X	X	X	X	X
16x190	X	X	X	X	X	X	X	X
20x260	X	X	X	X	X	X	X	X
24x300	X	X	X	X	X	X	X	X
30x380	X	X	X	X	X	X	X	X

ÖVRIGA DIMENSIONER OCH LÄNGDER MOT FÖRFRÅGAN !

STARTKOSTNAD 150 SEK FÖR ORDER UNDER 1000 SEK.

ARTIKELLISTA
2013-2014
HELGÄNGAD STÅNG
MHGS DIN 976
ROSTFRI A2 - SYRAFAST A4
ENLIGT NY STANDARD A4-70 UPP TOM M24

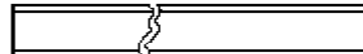

C:A PRIS/100 ST					
DIM	A2-70		A4-70 / A4		
	1M	2M	1M	2M	3M
M3			X		
M4			X		
M5			X		
M6	X	X	X	X	
M8	X	X	X	X	
M10	X	X	X	X	
M12	X	X	X	X	
M14	X		X		
M16	X	X	X	X	
M18			X		
M20	X	X	X	X	
M22			X		
M24	X	X	X	X	
M27			X		
M30			X	X	
M33			X		
M36			X		

ÖVRIGA DIMENSIONER OCH LÄNGDER MOT FRÖFRÅGAN !

BESTÄLLNINGSEXEMPEL: 26050161000 - MHGS M16 A2
 BESTÄLLNINGSEXEMPEL: 26050162000 - MHGS M16X2000 A2
 BESTÄLLNINGSEXEMPEL: 26051161000 - MHGS M16 A4
 BESTÄLLNINGSEXEMPEL: 26051162000 - MHGS M16X2000 A4

SWEBOLT AB
TEL 08 - 555 975 00 FAX 08 - 583 581 82

ARTIKELLISTA
2013-2014
HELGÄNGAD PINNE MHPS
 LÄNGDTOLERANS ±2mm



ROSTFRI A2

C:A PRIS/100 ST									
DIM	M6	M8	M10	M12	M16	M20	M24	M27	M30
50	X	X	X						
60	X	X	X	X					
70	X	X	X	X	X				
80	X	X	X	X	X	X			
90	X	X	X	X	X	X			
100	X	X	X	X	X	X	X		
110	X	X	X	X	X	X	X	X	
120	X	X	X	X	X	X	X	X	
130	X	X	X	X	X	X	X	X	
140	X	X	X	X	X	X	X	X	
150	X	X	X	X	X	X	X	X	
160	X	X	X	X	X	X	X	X	
180	X	X	X	X	X	X	X	X	
200	X	X	X	X	X	X	X	X	
220		X	X	X	X	X	X	X	
230		X	X	X	X	X	X	X	
240		X	X	X	X	X	X	X	
250		X	X	X	X	X	X	X	
260		X	X	X	X	X	X	X	
280		X	X	X	X	X	X	X	
300		X	X	X	X	X	X	X	
320		X	X	X	X	X	X	X	
330		X	X	X	X	X	X	X	
340			X	X	X	X	X	X	

SYRAFAST A4

C:A PRIS/100 ST									
DIM	M6	M8	M10	M12	M16	M20	M24	M27	M30
50	X	X	X						
60	X	X	X	X					
70	X	X	X	X	X				
80	X	X	X	X	X	X			
90	X	X	X	X	X	X			
100	X	X	X	X	X	X	X		
110	X	X	X	X	X	X	X	X	
120	X	X	X	X	X	X	X	X	
130	X	X	X	X	X	X	X	X	
140	X	X	X	X	X	X	X	X	
150	X	X	X	X	X	X	X	X	
160	X	X	X	X	X	X	X	X	
180	X	X	X	X	X	X	X	X	
200	X	X	X	X	X	X	X	X	
220		X	X	X	X	X	X	X	
230		X	X	X	X	X	X	X	
240		X	X	X	X	X	X	X	
250		X	X	X	X	X	X	X	
260		X	X	X	X	X	X	X	
280		X	X	X	X	X	X	X	
300		X	X	X	X	X	X	X	
320		X	X	X	X	X	X	X	
330		X	X	X	X	X	X	X	
340			X	X	X	X	X	X	

STARTKOSTNAD 150 SEK FÖR ORDER UNDER 1000 SEK.

ÖVRIGA DIMENSIONER OCH LÄNGDER MOT FÖRFRÅGAN !

SWEBOLT AB











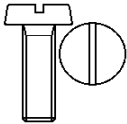
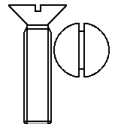
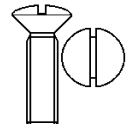
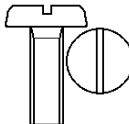
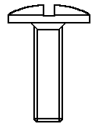
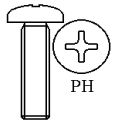

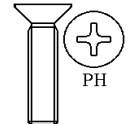

TEL 08 - 555 975 00 FAX 08 - 583 581 82

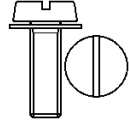
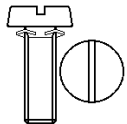
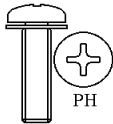
ARTIKELLISTA
2013-2014
SNEDKAPAD PINNE
FÖR KEMANKARE
A2 - A4

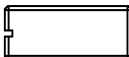
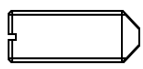
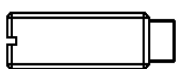
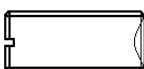
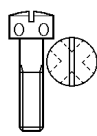

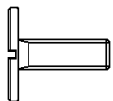
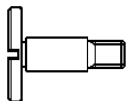
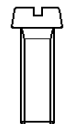
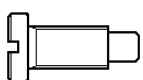
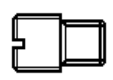
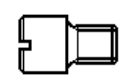
C:A PRIS/100 ST		
DIM	A2	A4
8x110	X	X
10x130	X	X
10x180	X	X
12x160	X	X
16x190	X	X
20x260	X	X
24x300	X	X

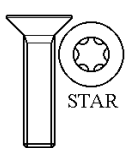
ÖVRIGA DIMENTIONER OCH LÄNGDER MOT FÖRFRÅGAN !

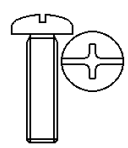
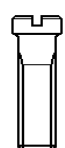
- 1 - 	- 2 - 	- 3 - 	- 4 - 
- 5 - 	- 6 - 	- 7 - 	- 8 - 
- 9 - 	- 10 - 	- 11 - 	- 12 - 
- 13 - 	- 14 - 	- 15 - 	- 16 - 
- 17 - 	- 18 - 	- 19 - 	- 20 - 
- 21 - 	- 22 - 	- 23 - 	- 24 - 
- 25 - 	- 26 - 	- 27 - 	- 28 - 
- 29 - 	- 30 - 	- 31 - 	- 32 - 

SWEBOLT AB

TEL. 08-584 909 60 FAX. 08-583 581 82

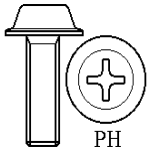
- 33 - 	- 34 -	- 35 -	- 36 -
- 37 -	- 38 -	- 39 -	- 40 -
- 41 -	- 42 -	- 43 -	- 44 -
- 45 -	- 46 -	- 47 -	- 48 -
- 49 -	- 50 -	- 51 -	- 52 -
- 53 -	- 54 -	- 55 -	- 56 -
- 57 -	- 58 -	- 59 -	- 60 -
- 61 -	- 62 -	- 63 -	- 64 -

SWEBOLT AB

TEL. 08-584 909 60 FAX. 08-583 581 82

PRODUKTER I STÅL

1	17000	MCS, CYLINDRISK SKALLE	84	1207	4.8	OBEH	7:1
1	17001	MCS, CYLINDRISK SKALLE	84	1207	4.8	FZB	7:1
1	17006	MCS, CYLINDRISK SKALLE ISO		1207	4.8	OBEH	7:2
1	17007	MCS, CYLINDRISK SKALLE ISO		1207	4.8	FZB	7:2
1	17003	MCS, CYLINDRISK SKALLE	84	1207	8.8	FZB	7:2
1	17008	MCS, CYLINDRISK SKALLE ISO		1207	8.8	FZB	7:2
1	17004	MCLS, LITEN CYLINDRISK SKALLE			4.8	FZB	7:2
1	17005	ULCS, CYLINDRISK SKALLE	UNC		4.8	FZB	7:21
2	17010	MFS, FÖRSÄNKT	963	2009	4.8	OBEH	7:3
2	17011	MFS, FÖRSÄNKT	963	2009	4.8	FZB	7:3
2	17014	MFS, FÖRSÄNKT ISO		2009	4.8	OBEH	7:3
2	17015	MFS, FÖRSÄNKT ISO		2009	4.8	FZB	7:3
2	17013	MFS, FÖRSÄNKT	963	2009	8.8	FZB	7:4
2	17016	MFS, FÖRSÄNKT ISO		2009	8.8	FZB	7:4
2	17019	UFS, FÖRSÄNKT	UNC		4.8	FZB	7:21
2	17018	MFLS, LITEN FÖRSÄNKT				FZB	7:15
3	17020	MKFS, KULLERFÖRSÄNKT	964	2010	4.8	OBEH	7:5
3	17021	MKFS, KULLERFÖRSÄNKT	964	2010	4.8	FZB	7:5
3	17023	MKFS, KULLERFÖRSÄNKT ISO		2010	4.8	FZB	7:5
4	17031	MSCS, STOR CYL SKALLE	85	1580	4.8	FZB	7:7
4	17033	MSCS, STOR CYL SKALLE	85	1580	8.8	FZB	7:8
5	17041	LKCS, STOR LÅG KULLERSKALLE			4.6	FZB	7:12
5	17046	MKSS, METRISK KULLRIG STOR SKALLE			4.8	FZB	7:15
6	17050	MRX, CYL. KULLRIG, PH	7985	7045	4.8	OBEH	7:9
6	17051	MRX, CYL. KULLRIG, PH	7985	7045	4.8	FZB	7:9
6	17052	MRX, CYL. KULLRIG, PH	7985	7045	4.8	SVOX	7:9
6	17056	MRX, CYL. KULLRIG, PH	7985	7045	4.8	FZS	7:9
6	17057	MRX, CYL. KULLRIG, PH ISO		7045	4.8	FZB	7:9
6	17058	MRX, CYL. KULLRIG, PH ISO		7045	8.8	FZB	7:9
7	17061	MRX, CYL. KULLRIG., POZI	7985	7045	4.8	FZB	7:9
7	17063	MRX, CYL. KULLRIG., POZI ISO		7045	4.8	FZB	7:9
28	17053	MRT, CYL. KULLRIG. STAR	7985	7045	4.8	FZB	7:12
28	17054	MRT, CYL. KULLRIG. STAR ISO		7045	4.8	FZB	7:12
28	17055	MRT, CYL. KULLRIG. STAR	7985	7045	8.8	FZB	7:12
28	17059	MRT, CYL. KULLRIG. STAR ISO		7045	8.8	FZB	7:12
6	17069	MRLX, LITEN CYL. KULLRIG, PH	~7985	~7045	4.8	FZB	7:22
8	17080	MFX, FÖRSÄNKT, PH	965	7046	4.8	OBEH	7:10
8	17081	MFX, FÖRSÄNKT, PH	965	7046	4.8	FZB	7:9
8	17085	MFX, FÖRSÄNKT, PH ISO		7046	4.8	FZB	7:9
9	17091	MFX, FÖRSÄNKT, POZI	965	7046	4.8	FZB	7:9
9	17086	MFX, FÖRSÄNKT, POZI ISO		7046	4.8	FZB	7:9

SWEBOLT AB

TEL. 08-584 909 60 FAX. 08-583 581 82

BILD	ART.GR.	BENÄMNING	DIN	ISO	KVAL	YTBEH	SIDA
29	17082	MFT, FÖRSÄNKTK, STAR	965	7046	4.8	OBEH	7:13
29	17083	MFT, FÖRSÄNKTK, STAR	965	7046	4.8	FZB	7:13
29	17088	MFT, FÖRSÄNKTK, STAR ISO		7046	4.8	FZB	7:13
29	17084	MFT, FÖRSÄNKTK, STAR	965	7046	8.8	FZB	7:13
29	17089	MFT, FÖRSÄNKTK, STAR ISO		7046	8.8	FZB	7:13
10	17111	MKFX, KULLERFÖRS., PH	966	7047	4.8	FZB	7:10
10	17113	MKFX, KULLERFÖRS., PH ISO	7047	4.8	FZB	7:10	
11	17121	MKFX, KULLERFÖRS., POZI	966	7047	4.8	FZB	7:10
11	17123	MKFX, KULLERFÖRS., POZI ISO		7047	4.8	FZB	7:10
30	17115	MKFT, KULLERFÖRS., STAR	966	7047	4.8	FZB	7:11
30	17117	MKFT, KULLERFÖRS., STAR ISO		7047	4.8	FZB	7:11
12	17130	MCS Z1, OFÖRLORBAR BR.	84 Z1/6902A		4.8	FZB	7:16
13	17140	MCS Z4, OFÖRLORBAR LÅSBR.	84 Z4/6905		4.8	FZB	7:16
14	17150	MRX Z1, OFÖRLORBAR BR.	7985 Z1/6902A		4.8	FZB	7:16
15	17160	MRX Z4, OFÖRLORBAR LÅSBR.	7985 Z4/6905		4.8	FZB	7:16
16	17170	PSS, STOPPSKRUV PLAN SPÅR	551	4766		OBEH	7:14
16	17171	PSS, STOPPSKRUV PLAN SPÅR	551	4766		FZB	7:14
17	17180	SSS, STOPPSKRUV SPETSIG SPÅR	553	7434		OBEH	7:14
17	17181	SSS, STOPPSKRUV SPETSIG SPÅR	553	7434		FZB	7:14
18	17190	TSS, STOPPSKRUV TAPP SPÅR	417	7435		OBEH	7:14
18	17191	TSS, STOPPSKRUV TAPP SPÅR	417	7435		FZB	7:14
19	17200	SKSS, STOPPSKR. SKÅLAD SPÅR	438	7436		OBEH	7:14
19	17201	SKSS, STOPPSKR. SKÅLAD SPÅR	438	7436		FZB	7:14
20	17210	SXH, SPÅRSKRUV m. KRYSSHÅL	404			OBEH	7:20
20	17211	SXH, SPÅRSKRUV m. KRYSSHÅL	404			FZB	7:20
21	17220	LP, LÅSPINNE m. SPÅR	427	2342		OBEH	7:17
21	17221	LP, LÅSPINNE m. SPÅR	427	2342		FZB	7:17
22	17230	FLSS, FLATSKALLIG SPÅRSKRUV	921			OBEH	7:12
22	17231	FLSS, FLATSKALLIG SPÅRSKRUV	921			FZB	7:12
23	17240	AS, ANSATSSKRUV	923			OBEH	7:17
24	17046	MCSL, LITEN SKALLE			4.8	FZB	7:6
25	17260	LITEN SKALLE + TAPP	922			OBEH	7:18
26	17270	GÄNGAD PINNE MED TAPP	926			OBEH	7:18
27	17280	TAPPSKRUV	927			OBEH	7:18
31	17111	MRXC, COMBISPÅRSKRUV + PH				FZB	7:19

SWEBOLT AB

TEL. 08-584 909 60 FAX. 08-583 581 82

BILD	ART.GR.	BENÄMNING	DIN	ISO	KVAL	YTBEH	SIDA
32	17250	ASL, ANSATSSKRUV, LITEN SKA.	920			OBEH	7:19
33	17101	ECO-FIX, RUNDAT HUVUD FLÄNS, PH				FZB	7:22
<u>ROSTFRITT / SYRAFAST</u>							
1	27000	MCS, CYLINDRISK SKALLE	84	1207	A2		7:41
1	27001	MCS, CYLINDRISK SKALLE	84	1207	A4		7:41
1	27006	MCS, CYLINDRISK SKALLE ISO		1207	A2		7:41
1	27007	MCS, CYLINDRISK SKALLE ISO		1207	A4		7:41
1	27005	ULCS, CYLINDRISK SKALLE	UNC		A4		7:56
2	27010	MFS, FÖRSÄNK	963	2009	A2		7:42
2	27011	MFS, FÖRSÄNK	963	2009	A4		7:42
2	27014	MFS, FÖRSÄNK ISO		2009	A2		7:42
2	27015	MFS, FÖRSÄNK ISO		2009	A4		7:42
2	27018	MFLS, FÖRSÄNK, LITEN SKALLE			A2		7:57
2	27015	UFS, FÖRSÄNK	UNC		A4		7:56
3	27020	MKFS, KULLERFÖRSÄNK	964	2010	A2		7:43
3	27021	MKFS, KULLERFÖRSÄNK	964	2010	A4		7:43
3	27022	MKFS, KULLERFÖRSÄNK ISO		2010	A2		7:43
3	27023	MKFS, KULLERFÖRSÄNK ISO		2010	A4		7:43
3	27024	MKFS, KULLERFÖRSÄNK, LITEN SKALLE			A2		
4	27030	MSCS, STOR CYL. SKALLE	85	1580	A2		7:51
4	27031	MSCS, STOR CYL. SKALLE	85	1580	A4		7:52
5	27041	LKCS, KULLRIG STOR SKALLE			A2		7:50
5	27042	LKCS, KULLRIG STOR SKALLE			A4		7:50
6	27050	MRX, CYL. KULLRIG, PH	7985	7045	A2		7:44
6	27051	MRX, CYL. KULLRIG, PH	7985	7045	A4		7:44
6	27056	MRX, CYL. KULLRIG, PH ISO		7045	A2		7:44
6	27057	MRX, CYL. KULLRIG, PH ISO		7045	A4		7:44
7	27060	MRX, CYL. KULLRIG, POZI	7985	7045	A2		7:44
7	27061	MRX, CYL. KULLRIG, POZI	7985	7045	A4		7:44
7	27062	MRX, CYL. KULLRIG, POZI ISO		7045	A2		7:44
7	27063	MRX, CYL. KULLRIG, POZI ISO		7045	A4		7:44
28	27052	MRT, CYL. KULLRIG, STAR	7985	7045	A2		7:47
28	27053	MRT, CYL. KULLRIG STAR	7985	7045	A4		7:47
28	27054	MRT, CYL. KULLRIG, STAR ISO		7045	A2		7:47
28	27055	MRT, CYL. KULLRIG, STAR ISO		7045	A4		7:47
8	27080	MFX, FÖRSÄNK, PH	965	7046	A2		7:45
8	27081	MFX, FÖRSÄNK, PH	965	7046	A4		7:45
8	2708	MFX, FÖRSÄNK, PH ISO		7046	A2		7:45
8	2708	MFX, FÖRSÄNK, PH ISO		7046	A4		7:45

SWEBOLT AB

TEL. 08-584 909 60 FAX. 08-583 581 82

BILD	ART.GR.	BENÄMNING	DIN	ISO	KVAL	YTBEH	SIDA
9	27090	MFX, FÖRSÄNKTK, POZI	965	7046	A2		7:45
9	27091	MFX, FÖRSÄNKTK, POZI	965	7046	A4		7:45
9	27085	MFX, FÖRSÄNKTK, POZI ISO		7046	A2		7:45
9	27086	MFX, FÖRSÄNKTK, POZI ISO		7046	A4		7:45
29	27082	MFT, FÖRSÄNKTK, STAR	965	7046	A2		7:48
29	27083	MFT, FÖRSÄNKTK, STAR	965	7046	A4		7:48
29	27087	MFT, FÖRSÄNKTK, STAR ISO		7046	A2		7:48
29	27088	MFT, FÖRSÄNKTK, STAR ISO		7046	A4		7:48
10	27110	MKFX, KULLERFÖRS., PH	966	7047	A2		7:46
10	27111	MKFX, KULLERSÖRS., PH	966	7047	A4		7:46
10	27112	MKFX, KULLERFÖRS., PH ISO		7047	A2		7:46
10	27113	MKFX, KULLERSÖRS., PH ISO		7047	A4		7:46
11	27120	MKFX, KULLERFÖRS., POZI	966	7047	A2		7:46
11	27121	MKFX, KULLERSÖRS., POZI	966	7047	A4		7:46
11	27122	MKFX, KULLERFÖRS., POZI ISO		7047	A2		7:46
11	27123	MKFX, KULLERSÖRS., POZI ISO		7047	A4		7:46
30	27114	MKFT, KULLERFÖRS., STAR	966	7047	A2		7:49
30	27115	MKFT, KULLERFÖRS., STAR	966	7047	A4		7:49
30	27116	MKFT, KULLERFÖRS., STAR ISO		7047	A2		7:49
30	27117	MKFT, KULLERFÖRS., STAR ISO		7047	A4		7:49
16	27170	PSS, STOPPSKRUV PLAN SPÅR	551	4766	A1		7:54
16	27171	PSS, STOPPSKRUV PLAN SPÅR	551	4766	A4		7:54
17	27180	SSS, STOPPSKRUV SPETSIG SPÅR	553	7434	A1		7:54
17	27181	SSS, STOPPSKRUV SPETSIG SPÅR	553	7434	A4		7:54
18	27190	TSS, STOPPSKRUV TAPP SPÅR	417	7435	A2		7:55
18	27191	TSS, STOPPSKRUV TAPP SPÅR	417	7435	A4		7:55
19	27200	SKSS, STOPPSKR. SKÅLAD SPÅR	438	7436	A2		7:55
19	27201	SKSS, STOPPSKR. SKÅLAD SPÅR	438	7436	A4		7:55
33	27101	ECO-FIX, RUNDAT HUVUD FLÄNS, PH			A2		7:53

MÄSSING

1	37000	MCS, CYLINDRISK SKALLE	84	1207			7:60
1	37001	MCS, CYLINDRISK SKALLE	84	1207		FÖRNICKLAD	7:60
2	37010	MFS, FÖRSÄNKTK	963	2009			7:61
2	37011	MFS, FÖRSÄNKTK	963	2009		FÖRNICKLAD	7:61
3	37020	MKFS, KULLERFÖRSÄNKTK	964	2010			7:62
3	37021	MKFS, KULLERFÖRSÄNKTK	964	2010		FÖRNICKLAD	7:62
4	37030	MSCS, STOR CYL. SKALLE	85	1580			7:63
4	37031	MSCS, STOR CYL. SKALLE	85	1580		FÖRNICKLAD	7:63

SWEBOLT AB

TEL. 08-584 909 60 FAX. 08-583 581 82

<u>BILD</u>	<u>ART.GR.</u>	<u>BENÄMNING</u>	<u>DIN</u>	<u>ISO</u>	<u>KVAL</u>	<u>YTBEH</u>	<u>SIDA</u>
5	37041	LKCS, STOR LÅG KULLERSKALLE				FÖRNICKLAD	7:64
16	37170	PSS, STOPPSKRUV PLAN SPÅR	551	4766			7:65
17	37180	SSS, STOPPSKRUV SPETSIG SPÅR	553	7434			7:65
22	37230	FLSS, FLATSKALLIG SPÅRSKRUV	921				7:66

POLYAMID

1	47000	MCS, CYLINDRISK SKALLE	84	1207			7:80
2	47010	MFS, FÖRSÄNK	963	2009			7:80
3	47020	MKFS, KULLERFÖRSÄNK	964	2010			7:81
4	47030	MSCS, STOR CYL. SKALLE	85	1580			7:81
5	47040	LKCS, STOR LÅG KULLERSK.					7:81
16	47170	PSS, STOPPSKRUV PLAN SPÅR	551	4766			7:81

ALUMINIUM

1	67000	MCS, CYLINDRISK SKALLE	84	1207			7:70
2	67010	MFS, FÖRSÄNK	963	2009			7:71
3	67020	MKFS, KULLERFÖRSÄNK	964	2010			7:71

SWEBOLT AB

TEL. 08-584 909 60 FAX. 08-583 581 82



ARTIKELLISTA

2013-2014

CYLINDRISK SPÅRSKRUV

MCS 4.8 DIN 84 FZB

BLANKFÖRZINKAD

DIM	M1.6	M2	M2.3	M2.5	M2.6	M3	M4	M5	M6	M8	M10
Skalld	3	3.8	4.4	4.5	5	5.5	7	8.5	10	13	16
Skallh	1	1.3	1.5	1.6	1.7	2	2.6	3.3	3.9	5	6
Längd	C:A PRIS/100 ST										
2	X	X									
3	X	X	X	X	X	X					
4	X	X	X	X	X	X	X				
5	X	X	X	X	X	X	X	X			
6	X	X	X	X	X	X	X	X			
8	X	X	X	X	X	X	X	X	X		
10	X	X	X	X	X	X	X	X	X	X	
12		X	X	X	X	X	X	X	X	X	
14		X	X	X	X	X	X	X	X		
16		X	X	X	X	X	X	X	X	X	X
18		X	X	X	X	X	X	X	X		
20		X	X	X	X	X	X	X	X	X	X
22		X		X	X	X	X	X	X	X	
25		X		X	X	X	X	X	X	X	X
30		X		X	X	X	X	X	X	X	X
35						X	X	X	X	X	
40						X	X	X	X	X	X
45						X	X	X	X	X	
50						X	X	X	X	X	X
55						X	X	X	X		
60						X	X	X	X	X	X
65									X		
70							X	X	X	X	X
75								X			
80							X	X	X	X	X
90							X	X	X		
100							X	X	X	X	X
120									X		

ÖVRIGA DIMENSIONER OCH LÄNGDER MOT FÖRFRÅGAN !

FÖRP.	M1.6	M2	M2.3	M2.5	M2.6	M3	M4	M5	M6	M8	M10
500 ST	2-	4-	3-	6-	3-	4-	4-	6-			
200 ST						35-	35-	35-	8-		
100 ST									90-	10-	12-

BESTÄLLNINGSEXEMPEL: 1700106025 - MCS M6X25 4.8 FZB

SWEBOLT AB

TEL 08 - 555 975 00 FAX 08 - 583 581 82



ARTIKELLISTA
2013-2014
FÖRSÄNKT SPÅRSKRUV
MFS FZB DIN 963
BLANKFÖRZINKAD

DIM	M1	M1.2	M1.4	M1.6	M2	M2.3	M2.5	M2.6	M3	M4	M5	M6	M8	M10	M12	M16
Skalld	1.9	2.3	2.6	3.8	4.7	4.5	4.7	5	5.6	7.5	9.2	11	14.5	18	22	29
Skallh	0.6	0.72	0.84	0.96	1.2	1.3	1.5	1.5	1.65	2.2	2.5	3	4	5	6	8
Längd	C:A PRIS/100 ST															
2																
3																
4					X		X									
5				X	X		X									
6					X		X		X	X						
8					X		X		X	X	X					
10					X		X		X	X	X	X	X			
12							X		X	X	X	X	X			
14									X	X	X	X	X			
16					X		X		X	X	X	X	X	X		
18									X		X					
20							X		X	X	X	X	X	X		
22											X					
25							X		X	X	X	X	X	X		
30							X		X	X	X	X	X	X	X	
35									X	X	X	X	X	X	X	
40									X	X	X	X	X	X	X	
45									X		X	X				
50									X	X	X	X	X	X	X	
55																
60									X	X	X	X	X	X	X	
65																
70											X	X	X	X		
75																
80											X	X	X	X		
90												X	X			
100												X	X	X		
110																
120																
130																

ÖVRIGA DIMENSIONER OCH LÄNGDER MOT FÖRFRÅGAN !

FÖRP.	M1	M1.2	M1.4	M1.6	M2	M2.3	M2.5	M2.6	M3	M4	M5	M6	M8	M10	M12	M16
500 ST				3-	4-	4-	4-	4-	4-	5-	6-					
200 ST									35-	35-	35-	8-				
100 ST												80-	10-	16-		
50 ST															20-	
25 ST																25-

BESTÄLLNINGSEXEMPEL: 1701104020 - MFS M4X20 4.8 FZB

SWEBOLT AB
TEL 08 - 555 975 00 FAX 08 - 583 581 82



ARTIKELLISTA

2013-2014

KRYSSPÅRSKRUV

BLANKFÖRZINKAD

MRX FZB DIN 7985 PHILLIPS

DIM	M1.6	M2	M2.5	M3	M4	M5	M6	M8	M10
Skalld	3.2	4	5	6	8	10	12	16	20
Skallh	1.3	1.6	2	2.4	3.1	3.8	4.6	6	7.5
Längd	C:A PRIS/100 ST								
3		X	X						
4		X	X	X	X				
5		X	X	X	X				
6		X	X	X	X	X	X		
8		X	X	X	X	X	X		
10		X	X	X	X	X	X		
12		X	X	X	X	X	X	X	
14				X	X	X	X		
16		X	X	X	X	X	X	X	X
18				X	X	X	X		
20		X	X	X	X	X	X	X	X
22				X	X	X			
25			X	X	X	X	X	X	X
30			X	X	X	X	X	X	X
35				X	X	X	X	X	X
40				X	X	X	X	X	X
45				X	X	X	X	X	
50				X	X	X	X	X	X
60					X	X	X	X	
70					X	X	X	X	
80					X	X	X	X	
100						X	X		

BESTÄLLNINGSEXEMPEL: 1705106020 - MRX M6X20 4.8 FZB PH

MFX FZB DIN 965 FÖRSÄNKT PHILLIPS



DIM	M2	M2.5	M3	M4	M5	M6	M8	M10
Skalld	3.8	4.7	5.6	7.5	9.2	11	14.5	15
Skallh	1.2	1.5	1.65	2.2	2.5	3	4	5
Längd	C:A PRIS/100 ST							
4			X					
5			X	X				
6		X	X	X				
8		X	X	X	X	X		
10		X	X	X	X	X		
12			X	X	X	X		
14			X	X	X	X		
16			X	X	X	X	X	X
20		X	X	X	X	X	X	X
22			X			X		
25			X	X	X	X	X	X
30			X	X	X	X	X	
35			X	X	X	X	X	
40			X	X	X	X	X	
45			X	X	X	X	X	
50			X	X	X	X	X	
60				X	X	X	X	
65				X				
70				X	X	X	X	
80				X	X	X	X	
90						X		
100						X		

BESTÄLLNINGSEXEMPEL: 1708106020 - MFX M6X20 4.8 FZB PH

ÖVRIGA DIMENSIONER OCH LÄNGDER MOT FÖRFRÅGAN !

FÖRP.	M1.6	M2	M2.5	M3	M4	M5	M6	M8	M10
500 ST	3-	3-	3-	4-	6-	6-			
200 ST				35-	35-	35-	10-		
100 ST					60-	70-	70-	16-	12-

SWEBOLT AB

TEL 08 - 555 975 00 FAX 08 - 583 581 82



ARTIKELLISTA

2013-2014

KULLEFÖRSÄNKT KRYSSPÅRSKRUV MKFX 4.8 DIN 966 FZB BLANKFÖRZINKAD

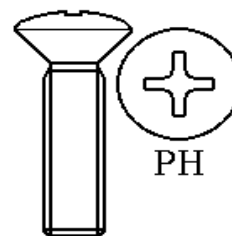

DIM	M2	M2.5	M3	M4	M5	M6	M8
Skalld	3.8	4.7	5.6	7.5	9.2	11	14.5
Skallh	1.2	1.5	1.65	2.2	2.5	3	4
Längd	C:A PRIS/100 ST						
4	X						
5	X	X	X				
6	X	X	X	X			
8	X	X	X	X	X		
10		X	X	X	X		
12		X	X	X	X	X	
14			X	X	X		
16			X	X	X	X	X
18			X	X		X	
20			X	X	X	X	X
25			X	X	X	X	X
30			X	X	X	X	X
35			X	X	X	X	X
40			X	X	X	X	X
45			X		X	X	
50				X	X	X	
60					X	X	
70						X	
80						X	
90							
100							

ÖVRIGA DIMENSIONER OCH LÄNGDER MOT FÖRFRÅGAN !

FÖRP.	M2	M2.5	M3	M4	M5	M6	M8
200 ST	4-	5-	5-	6-	8-	10-	
100 ST							16-

BESTÄLLNINGSEXEMPEL: 17121105025 - MKFX M5X25 4.8 FZB PH

BITS UNDER FLIK 18 !

SWEBOLT AB

TEL 08 - 555 975 00 FAX 08 - 583 581 82

ARTIKELLISTA
2013-2014
SPÅRSKRUV STAR
BLANKFÖRZINKAD
MRT KULLRIG
4.8 FZB



ERSÄTTTS AV 8.8 VARTEFTER
LAGER UTGÅR.

DIM	M2.5	M3	M4	M5	M6
Skalld		6	8	10	12
Skallh		2.4	3.1	3.8	4.6
S-nyckel		T10	T20	T25	T30
Längd	C:A PRIS/100 ST				
4		X			
5		X			
6	X	X			
8			X		
10		X	X	X	
12				X	
16			X	X	
20				X	X
25			X	X	X
30			X		
35					
40				X	X
50					X
60					
70					

BESTÄLLNINGSEXEMPEL: 1705306020 - MRT M6X20 4.8 FZB STAR

MFT FÖRSÄNKT
4.8 FZB

ERSÄTTTS AV 8.8 VARTEFTER
LAGER UTGÅR.

DIM	M3	M4	M5	M6
Skalld	5.6	7.5	9.2	11
Skallh	1.6	2.2	2.5	3
S-nyckel	T10	T20	T25	T30
Längd	C:A PRIS/100 ST			
6				
8			X	
10		X		
12	X		X	X
14				
16			X	X
20				
25			X	X
30			X	X
35				
40				
45				
50				
60				
70				

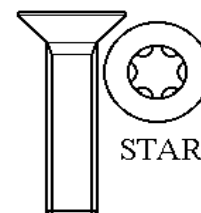

BESTÄLLNINGSEXEMPEL: 1708306020 - MFT M6X20 4.8 FZB STAR

ÖVRIGA DIMENSIONER OCH LÄNGDER MOT FÖRFRÅGAN !

FÖRP.	M3	M4	M5	M6
500 ST	6-	6-	8-	
200 ST		35-	35-	8-

SWEBOLT AB

TEL 08 - 555 975 00 FAX 08 - 583 581 82

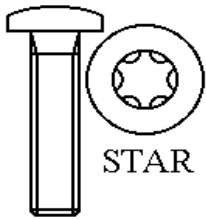

ARTIKELLISTA
2013-2014
SPÅRSKRUV STAR
BLANKFÖRZINKAD
MRT KULLRIG
8.8 FZB

DIM	M3	M4	M5	M6
Skalld	6	8	10	12
Skallh	2.4	3.1	3.8	4.6
S-nyckel	T10	T20	T25	T30
Längd	C:A PRIS/100 ST			
4				
5	X			
6	X	X		
8		X	X	
10		X	X	X
12		X	X	X
14	X			
16		X	X	X
20		X	X	X
25		X	X	X
30		X	X	X
35		X	X	X
40		X	X	X
45		X	X	X
50		X	X	X

BESTÄLLNINGSEXEMPEL: 1705506020 - MRT M6X20 8.8 FZB STAR

MFT FÖRSÄNKT

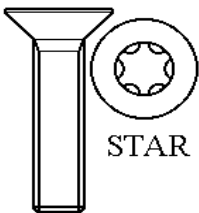

DIM	M3	M4	M5	M6
Skalld	5.6	7.5	9.2	11
Skallh	1.6	2.2	2.5	3
S-nyckel	T10	T20	T25	T30
Längd	C:A PRIS/100 ST			
5	X			
6	X	X		
8	X	X		
10		X	X	X
12	X	X	X	X
14				
16	X	X	X	X
20	X	X	X	X
25		X	X	X
30		X	X	X
35		X	X	X
40		X	X	X
45		X	X	X
50		X	X	X
60		X		

BESTÄLLNINGSEXEMPEL: 1708406020 - MFT M6X20 8.8 FZB STAR

ÖVRIGA DIMENSIONER OCH LÄNGDER MOT FÖRFRÅGAN !

FÖRP.	M3	M4	M5	M6
500 ST	6-	6-	8-	
200 ST		35-	35-	8-

SWEBOLT AB

TEL 08 - 555 975 00 FAX 08 - 583 581 82

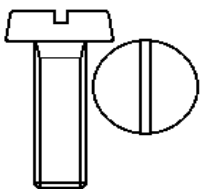

ARTIKELLISTA
2013-2014
CYLINDRISK SPÅRSKRUV
MCS DIN 84 ROSTFRI A2

DIM	M1.4	M1.6	M2	M2.3	M2.5	M2.6	M3	M3.5	M4	M5	M6	M8	M10
Skalld	2.6	3	3.8	4.4	4.5	5	5.5	6	7	8.5	10	13	16
Skallh	0.9	1	1.3	1.5	1.6	1.7	2	2.4	2.6	3.3	3.9	5	6
Längd	C:A PRIS/100 ST												
3	X	X	X	X	X	X	X						
4	X	X	X	X	X	X	X						
5	X	X	X	X	X	X	X	X					
6	X	X	X	X	X	X	X	X	X				
8	X	X	X	X	X	X	X	X	X	X			
10	X	X	X	X	X		X	X	X	X	X	X	
12	X	X	X	X	X		X	X	X	X	X	X	
14		X	X		X		X		X	X	X	X	
16		X	X	X	X		X	X	X	X	X	X	X
20		X	X		X		X	X	X	X	X	X	X
25			X		X		X	X	X	X	X	X	X
30			X				X	X	X	X	X	X	X
35							X	X	X	X	X	X	X
40			X				X	X	X	X	X	X	X
45									X	X	X	X	X
50								X	X	X	X	X	X
60									X	X	X	X	X
70									X	X	X	X	X

BESTÄLLNINGSEXEMPEL: 2700003020 - MCS M3X20 A2

MCS DIN 84
SYRAFAST A4

DIM	M1.4	M1.6	M2	M2.3	M2.5	M2.6	M3	M3.5	M4	M5	M6	M8	M10
Längd	C:A PRIS/100 ST												
4		X	X	X	X		X						
5		X	X	X	X		X	X	X				
6		X	X	X	X		X	X	X	X			
8		X	X	X	X		X	X	X	X	X		
10		X	X	X	X		X	X	X	X	X	X	
12			X	X	X		X	X	X	X	X	X	
14			X				X		X	X	X		
16			X	X	X		X	X	X	X	X	X	X
20			X	X	X		X	X	X	X	X	X	X
25			X		X		X	X	X	X	X	X	X
30			X		X		X	X	X	X	X	X	X
35							X	X	X	X	X	X	X
40							X	X	X	X	X	X	X
45							X		X	X	X	X	X
50							X		X	X	X	X	X
55										X	X		
60									X	X	X	X	
70									X	X	X	X	
75											X	X	
80										X	X	X	
90										X	X	X	
100										X	X	X	

BESTÄLLNINGSEXEMPEL: 2700103020 - MCS M3X20 A4

KRYSSMARKERADE OCH ÖVRIGA ARTIKLAR MOT FÖRFRÅGAN !

FÖRP.	M1.4	M1.6	M2	M2.3	M2.5	M2.6	M3	M3.5	M4	M5	M6	M8	M10
500 ST	3-	3-											
200 ST			5-	5-	3-	3-	4-	10-	5-	6-	8-		
100 ST										45-	45-	12-	20-

SWEBOLT AB

TEL 08 - 555 975 00 FAX 08 - 583 581 82

ARTIKELLISTA
2013-2014
FÖRSÄNKT SPÅRSKRUV
MFS DIN 963
ROSTFRI A2

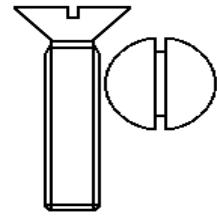

DIM	M2	M2.5	M3	M4	M5	M6	M8	M10
Skalld	3.8	4.7	5.6	7.5	9.2	11	14.5	18
Skallh	1.2	1.5	1.65	1	2.5	3	4	5
Längd	C:A PRIS/100 ST							
6								
8					X	X		
10				X	X	X		
12						X		
14			X		X			
16			X	X	X	X		
20				X	X	X		X
25				X	X	X		
30								
35				X		X		
40						X		
45								
50					X	X		
60								
70								
80							X	X
90					X		X	

BESTÄLLNINGSEXEMPEL: 2701005025 - MFS M5X25 A2

MFS A4 DIN 963
SYRAFAST A4

DIM	M2	M2.5	M3	M4	M5	M6	M8	M10
Längd	C:A PRIS/100 ST							
5	X	X						
6	X	X	X	X	X			
8	X	X	X	X	X	X		
10	X	X	X	X	X	X		
12			X	X	X	X		
14			X					
16			X	X	X	X	X	
20			X	X	X	X	X	
25			X	X	X	X	X	X
30			X	X	X	X	X	X
35				X	X	X	X	X
40			X	X	X	X	X	X
45				X		X	X	
50				X	X	X	X	X
60					X	X	X	X
70					X	X	X	X
75								
80					X	X	X	X
90					X	X	X	
100					X	X	X	X

BESTÄLLNINGSEXEMPEL: 2701108050 - MFS M8X50 A4

ÖVRIGA DIMENSIONER OCH LÄNGDER MOT FÖRFRÅGAN !

FÖRP.	M2	M2.5	M3	M4	M5	M6	M8	M10
500 ST	5-	5-						
200 ST			6-	6-	8-	8-		
100 ST					45-	45-	16-	20-

SWEBOLT AB
TEL 08 - 555 975 00 FAX 08 - 583 581 82

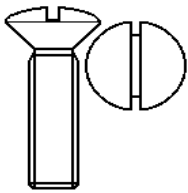

ARTIKELLISTA
2013-2014
KULLERFÖRSÄNKT SPÅRSKRUV
MKFS DIN 964 ROSTFRI A2

DIM	M3	M4	M5	M6	M8	M10
Skalld	5.6	7.5	9.2	11	14.5	18
Skallh	1.65	2.2	2.5	3	4	5
Längd	C:A PRIS/100 ST					
6	X					
8	X	X				
10	X	X	X			
12	X	X	X	X		
14		X				
16	X	X	X	X	X	
20	X	X	X	X	X	
25	X	X	X	X	X	
30	X	X	X	X	X	
35	X	X	X	X	X	
40		X	X	X	X	
45					X	
50		X	X	X	X	
60			X	X	X	
70			X	X		
80			X	X	X	
90						
100			X	X	X	

BESTÄLLNINGSEXEMPEL: 2702004008 - MKFS M4X8 A2

MKFS DIN 964
SYRAFAST A4

DIM	M3	M4	M5	M6	M8	M10
Längd	C:A PRIS/100 ST					
6	X	X				
8	X	X				
10	X	X	X	X		
12	X	X	X	X		
14						
16	X	X	X	X	X	
20	X	X	X	X	X	
25	X	X	X	X	X	
30	X	X	X	X	X	
35	X	X	X	X	X	
40	X	X	X	X	X	
45			X	X		
50		X	X	X	X	
60			X	X	X	
70			X	X	X	X
80			X	X	X	X
90			X	X		
100				X		

BESTÄLLNINGSEXEMPEL: 2702105010 - MKFS M5X10 A4

ÖVRIGA DIMENSIONER OCH LÄNGDER MOT FÖRFRÅGAN !

FÖRP.	M3	M4	M5	M6	M8	M10
200 ST	6-	8-	25-	10-		
100 ST				50-	16-	

SWEBOLT AB

TEL 08 - 555 975 00 FAX 08 - 583 581 82

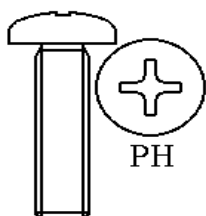

ARTIKELLISTA
2013-2014
KRYSSPÅRSKRUV
MRX DIN 7985
ROSTFRI A2



LAGERHÅLLNING FRÄMST I PHILLIPS

DIM	M2	M2.5	M3	M4	M5	M6	M8
Skalld	4	5	6	8	10	12	16
Skallh	1.6	2	2.4	3.1	3.8	4.6	6
C:A PRIS/100 ST							
Längd	PHILLIPS						
4							
5			X				
6			X	X			
8			X	X	X		
10		X	X	X	X	X	
12			X	X	X	X	
14			X	X	X		
16		X	X	X	X	X	
18							
20			X	X	X	X	
25			X	X	X	X	
30			X	X	X	X	
35			X	X	X	X	
40			X	X	X	X	
45				X	X	X	
50				X	X	X	

M2	M2.5	M3	M4	M5	M6	M8
4	5	6	8	10	12	16
1.6	2	2.4	3.1	3.8	4.6	6
C:A PRIS/100 ST						
POZI						
		X				
		X	X			
		X	X	X		
	X	X	X	X	X	
		X	X	X	X	
	X	X	X	X	X	
		X	X	X	X	
		X	X	X	X	
		X	X	X	X	
		X	X	X	X	
			X	X	X	
			X	X	X	

MRX DIN 7985
SYRAFAST A4

LAGERHÅLLNING FRÄMST I POZI

DIM	M2	M2.5	M3	M4	M5	M6	M8
C:A PRIS/100 ST							
Längd	PHILLIPS						
4							
5			X				
6			X	X			
8			X	X	X		
10			X	X	X	X	
12			X	X	X	X	
14			X	X	X		
16			X	X	X	X	
18							
20			X	X	X	X	
25			X	X	X	X	
30			X	X	X	X	
35			X	X	X	X	
40			X	X	X	X	
45				X	X	X	
50				X	X	X	
60							X
70							
80							

M2	M2.5	M3	M4	M5	M6	M8
C:A PRIS/100 ST						
POZI						
		X				
		X	X			
		X	X	X		
		X	X	X	X	
		X	X	X	X	
		X	X	X	X	
		X	X	X	X	
		X	X	X	X	
		X	X	X	X	
		X	X	X	X	
			X	X	X	
			X	X	X	

ÖVRIGA DIMENSIONER OCH LÄNGDER MOT FÖRFRÅGAN !

FÖRP.	M2	M2.5	M3	M4	M5	M6	M8
200 ST	4-	4-	5-	6-	8-	12-	20-

M2	M2.5	M3	M4	M5	M6	M8
4-	4-	4-	6-	8-	12-	

SWEBOLT AB

TEL 08 - 555 975 00 FAX 08 - 583 581 82

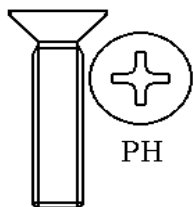

PH

ARTIKELLISTA

2013-2014

FÖRSÄNKT KRYSSPÅRSKRUV

MFX DIN 965 ROSTFRI A2

LAGERHÅLLNING FRÄMST I PHILIPS



POZI

DIM	M3	M4	M5	M6	M8
Skalld	5.6	7.5	9.2	11	15.4
Skallh	1.65	2.2	2.5	3	4
C:A PRIS/100 ST					
Längd	PHILLIPS				
4					
5					
6	X	X			
8	X	X			
10	X	X	X		
12	X	X	X	X	
16	X	X	X	X	
18					
20	X	X	X	X	X
25	X	X	X	X	X
30	X	X	X	X	
35		X	X	X	
40		X	X	X	
50		X	X	X	
55		X	X	X	
60			X		

M3	M4	M5	M6	M8
5.6	7.5	9.2	11	15.4
1.65	2.2	2.5	3	4
C:A PRIS/100 ST				
POZI				
X				
X	X			
X	X	X		
X	X	X	X	
X	X	X	X	
X	X	X	X	
X	X	X	X	
X	X	X	X	
	X	X	X	
	X	X	X	
	X	X	X	
	X	X	X	
	X	X	X	

MFX A4 DIN 965

SYRAFAST A4

LAGERHÅLLNING FRÄMST I POZI

DIM	M3	M4	M5	M6	M8
C:A PRIS/100 ST					
Längd	PHILLIPS				
4					
5					
6	X				
8	X	X	X		
10	X	X	X	X	
12	X	X	X	X	
16	X	X	X	X	X
18					
20	X	X	X	X	X
25	X	X	X	X	X
30	X	X	X	X	X
35		X	X	X	X
40		X	X	X	X
45		X	X	X	X
50		X	X	X	X
60			X		X

M3	M4	M5	M6	M8
C:A PRIS/100 ST				
POZI				
X	X			
X	X	X		
X	X	X	X	
X	X	X	X	
X	X	X	X	
X	X	X	X	X
X	X	X	X	X
X	X	X	X	X
	X	X	X	X
	X	X	X	X
	X	X	X	X
	X	X	X	X
	X	X	X	X

KRYSSMARKERADE ARTIKLAR MOT FÖRFRÅGAN !

FÖRP.	M3	M4	M5	M6	M8
200 ST	6-	6-	8-	10-	12-

M3	M4	M5	M6	M8
6-	6-	8-	10-	30-

SWEBOLT AB

TEL 08 - 555 975 00 FAX 08 - 583 581 82

ARTIKELLISTA

2013-2014

KULLRIG FÖRSÄNKT KRYSSPÅRSKRUV

MKFX DIN 966 ROSTFRI A2

LAGERHÅLLNING FRÄMST I PHILLIPS

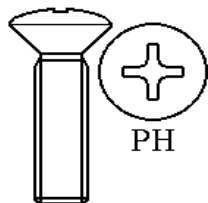

DIM	M3	M4	M5	M6	M8
Skalld	5.6	7.5	9.2	11	14.5
Skallh	1.6	2.2	2.5	3	4
C:A PRIS/100 ST					
Längd	PHILLIPS				
4					
5					
6	X				
8	X	X	X		
10	X	X	X		
12	X	X	X	X	
16	X	X	X	X	X
20	X	X	X	X	
25	X	X	X	X	
30	X	X	X	X	
35	X	X	X	X	
40	X	X	X	X	
45		X	X	X	
50		X	X	X	
60					

M3	M4	M5	M6	M8
5.6	7.5	9.2	11	14.5
1.6	2.2	2.5	3	4
C:A PRIS/100 ST				
POZI				
X				
X	X	X		
X	X	X		
X	X	X	X	
X	X	X	X	
X	X	X	X	
X	X	X	X	
X	X	X	X	
X	X	X	X	
X	X	X	X	
X	X	X	X	
X	X	X	X	
X	X	X	X	
X	X	X	X	
X	X	X	X	
X	X	X	X	
X	X	X	X	
X	X	X	X	
X	X	X	X	

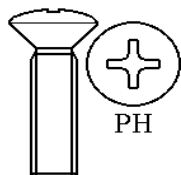

MKFX DIN 966

SYRAFAST A4

LAGERHÅLLNING FRÄMST I POZI



DIM	M3	M4	M5	M6	M8
C:A PRIS/100 ST					
Längd	PHILLIPS				
4					
5					
6	X				
8	X	X	X		
10	X	X	X	X	
12	X	X	X	X	
16	X	X	X	X	
20	X	X	X	X	
25	X	X	X	X	
30	X	X	X	X	
35	X	X	X	X	
40	X	X	X	X	
45		X	X	X	
50		X	X	X	
60					

M3	M4	M5	M6	M8
C:A PRIS/100 ST				
POZI				
X				
X	X	X		
X	X	X		
X	X	X	X	
X	X	X	X	
X	X	X	X	
X	X	X	X	
X	X	X	X	
X	X	X	X	
X	X	X	X	
X	X	X	X	
X	X	X	X	
X	X	X	X	
X	X	X	X	
X	X	X	X	
X	X	X	X	
X	X	X	X	
X	X	X	X	
X	X	X	X	
X	X	X	X	

ÖVRIGA DIMENSIONER OCH LÄNGDER MOT FÖRFRÅGAN !

FÖRP.	M3	M4	M5	M6	M8
200 ST	6-	10-	8-	10-	

M3	M4	M5	M6	M8
6-	10-	8-	10-	

SWEBOLT AB

TEL 08 - 555 975 00 FAX 08 - 583 581 82

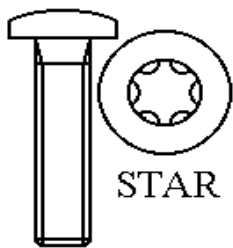

ARTIKELLISTA
2013-2014
KULLRIG SPÅRSKRUV STAR
MRT ~DIN 7985 ROSTFRI A2

DIM	M2.5	M3	M4	M5	M6	M8
Skalld	5	6	8	10	12	16
Skallh	2.1	2.4	3.1	3.8	4.6	6
S-nyckel	T8	T10	T20	T25	T30	T40
Längd	C:A PRIS/100 ST					
4	X					
5	X	X				
6	X	X	X			
8	X	X	X	X		
10	X	X	X	X	X	
12	X	X	X	X	X	
14	X	X	X	X	X	
16	X	X	X	X	X	
20	X	X	X	X	X	
22						
25	X	X	X	X	X	
30	X	X	X	X	X	
35		X	X	X	X	
40		X	X	X	X	
45			X	X	X	
50			X	X	X	

BESTÄLLNINGSEXEMPEL: 2705206020 - MRT M6X20 A2 STAR

MRT ~DIN 7985 SYRAFAST A4

DIM	M2.5	M3	M4	M5	M6	M8
Längd	C:A PRIS/100 ST					
4	X	X				
5	X	X				
6	X	X	X			
8	X	X	X	X		
10	X	X	X	X	X	
12	X	X	X	X	X	
14	X	X	X		X	
16	X	X	X	X	X	
20	X	X	X	X	X	
22			X	X		
25	X	X	X	X	X	
30	X	X	X	X	X	
35		X	X	X	X	
40		X	X	X	X	
45			X	X	X	
50			X	X	X	X

BESTÄLLNINGSEXEMPEL: 2705306020 - MRT M6X20 A4 STAR

KRYSSMARKERADE ARTIKLAR MOT FÖRFRÅGAN !

FÖRP.	
200 ST	SAMTLIGA

SWEBOLT AB
TEL 08 - 555 975 00 FAX 08 - 583 581 82

ARTIKELLISTA
2013-2014
FÖRSÄNKT SPÅRSKRUV STAR

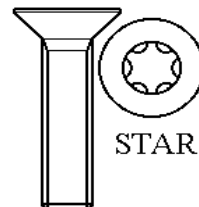

MFT ~DIN 965 ROSTFRI A2

DIM	M3	M4	M5	M6
Skalld	5.6	7.5	9.2	11
Skallh	1.6	2.2	2.5	3
S-nyckel	T10	T20	T25	T30
Längd	C:A PRIS/100 ST			
6	X			
8	X	X		
10	X	X	X	
12	X	X	X	X
14	X	X	X	X
16	X	X	X	X
20	X	X	X	X
25	X	X	X	X
30	X	X	X	X
35		X	X	X
40		X	X	X
45		X	X	X
50		X	X	X

BESTÄLLNINGSEXEMPEL: 2708205020 - MFT M5X20 A2 STAR

MFT ~DIN 965 SYRAFAST A4

DIM	M3	M4	M5	M6
Längd	C:A PRIS/100 ST			
6	X			
8	X	X		
10	X	X	X	
12	X	X	X	X
14			X	
16	X	X	X	X
20	X	X	X	X
25	X	X	X	X
30	X	X	X	X
35	X	X	X	X
40	X	X	X	X
45		X	X	X
50		X	X	X

BESTÄLLNINGSEXEMPEL: 2708305020 - MFT M5X20 A4 STAR

KRYSSMARKERADE ARTIKLAR MOT FÖRFRÅGAN !

FÖRP.	
200 ST	SAMTLIGA

BITS UNDER FLIK 18 !

SWEBOLT AB
TEL 08 - 555 975 00 FAX 08 - 583 581 82



ARTIKELLISTA
2013-2014
KULLERFÖRSÄNKT SPÅRSKRUV

MKFT A2 ~DIN 966 STAR
ROSTFRI

DIM	M2.5	M3	M4	M5	M6
Skalld	4.7	5.6	7.5	9.2	11
Skallh	1.5	1.65	2.2	2.5	3
S-nyckel	T8	T10	T20	T25	T30
Längd	C:A PRIS/100 ST				
4					
5					
6		X			
8		X	X	X	
10		X	X	X	
12		X	X	X	X
14					
16		X	X	X	X
20		X	X	X	X
25		X	X	X	X
30		X	X	X	X
35		X	X	X	X
40		X	X	X	X
45			X	X	X
50			X	X	X

BESTÄLLNINGSEXEMPEL: 2711403040 - MKFT M3X40 A2 STAR

MKFT A4 ~DIN 966
SYRAFAST

DIM	M2.5	M3	M4	M5	M6
Längd	C:A PRIS/100 ST				
4					
5					
6		X	X		
8		X	X	X	
10		X	X	X	
12		X	X	X	X
14					X
16		X	X	X	X
20		X	X	X	X
25		X	X	X	X
30		X	X	X	X
35		X	X	X	X
40		X	X	X	X
45			X	X	X
50			X	X	X

BESTÄLLNINGSEXEMPEL: 2711503040 - MKFT M3X40 A4 STAR

ÖVRIGA DIMENSIONER OCH LÄNGDER MOT FÖRFRÅGAN !

FÖRP.	
200 ST	SAMTLIGA

SWEBOLT AB

TEL 08 - 555 975 00 FAX 08 - 583 581 82

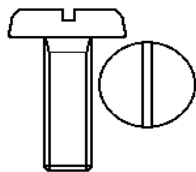

ARTIKELLISTA

2013-2014

SPÅRSKRUV MED STOR CYLINDRISK SKALLE MSCS DIN 85 A2

DIM	M3	M4	M5	M6
Skalld	6	8	10	12
Skallh	1.8	2.4	3	3.6
Längd	C:A PRIS/100 ST			
4		X		
6	X			
8				
10				
12			X	
14				
16			X	
20			X	
25				
30		X		
35				
40				
45				
50				

BESTÄLLNINGSEXEMPEL: 2703003016 - MSCS M3x16 A2

FÖRP.	M3	M4	M5	M6
500 ST	6-	5-		
200 ST			16-	

SWEBOLT AB

TEL 08 - 555 975 00 FAX 08 - 583 581 82

ARTIKELLISTA

2013-2014

SPÅRSKRUV MED STOR CYLINDRISK SKALLE MSCS DIN 85 A4

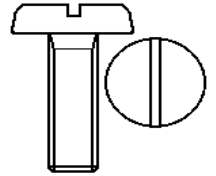

DIM	M3	M4	M5	M6
Skalld	6	8	10	12
Skallh	1.8	2.4	3	3.6
Längd	C:A PRIS/100 ST			
5		X		
6	X			
8	X			
10	X	X		
12				X
14				
16	X		X	X
20		X		X
25	X			
30				
35				
40				
45				
50				

BESTÄLLNINGSEXEMPEL: 2703103016 - MSCS M3x16 A4











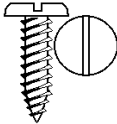
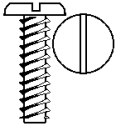
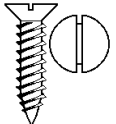
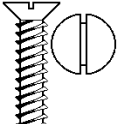
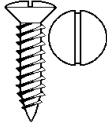
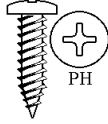

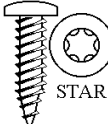
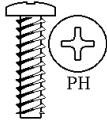
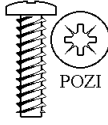
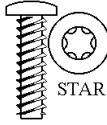
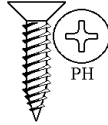

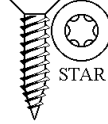
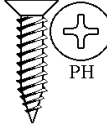

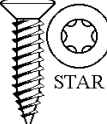
FÖRP.	M3	M4	M5	M6
500 ST	6-	5-		
200 ST			16-	12-

BITS UNDER FLIK 18 !

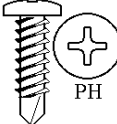
SWEBOLT AB

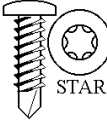
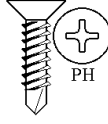

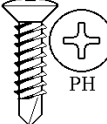

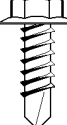
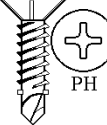
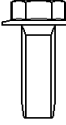





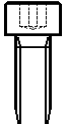

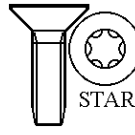

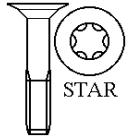
TEL 08 - 555 975 00 FAX 08 - 583 581 82

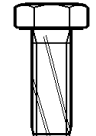
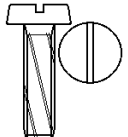
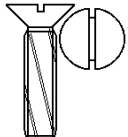
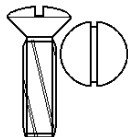
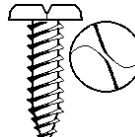
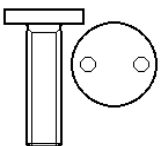
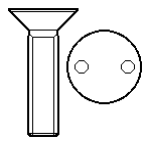
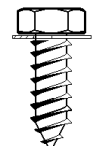
7:52

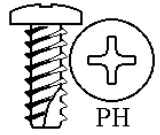
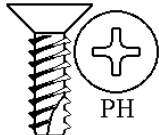
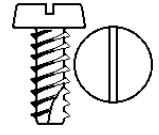
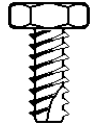
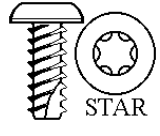
- 1 - 	- 2 - 	- 3 - 	- 4 - 
- 5 - 	- 6 -  PH	- 7 -  POZI	- 8 -  STAR
- 9 -  PH	- 10 -  POZI	- 11 -  STAR	- 12 -  PH
- 13 -  POZI	- 14 -  STAR	- 15 -  PH	- 16 -  POZI
- 17 -  STAR	- 18 - 	- 19 - 	- 20 - 
- 21 - 	- 22 -  POZI	- 23 -  STAR	- 24 -  PH
- 25 -  POZI	- 26 -  STAR	- 27 -  PH	- 28 -  POZI
- 29 -  STAR	- 30 - 	- 31 -  PH	- 32 - 

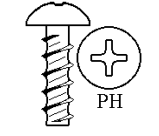
SWEBOLT AB

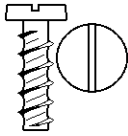
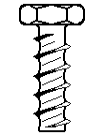
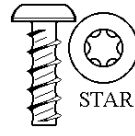
TEL. 08-584 909 60 FAX. 08-583 581 82

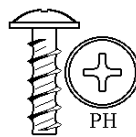
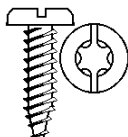
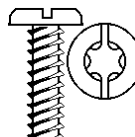
- 33 - 	- 34 - 	- 35 - 	- 36 - 
- 37 - 	- 38 - 	- 39 - 	- 40 - 
- 41 - 	- 42 - 	- 43 - 	- 44 - 
- 45 - 	- 46 - 	- 47 - 	- 48 - 
- 49 - 	- 50 - 	- 51 - 	- 52 - 
- 53 - 	- 54 - 	- 55 - 	- 56 - 
- 57 - 	- 58 - 	- 59 - 	- 60 - 
- 61 - 	- 62 - 	- 63 - 	- 64 - 

SWEBOLT AB

TEL. 08-584 909 60 FAX. 08-583 581 82

PRODUKTER I STÅL

1	18001	CSS, CYL. SKALLE, SPETS	7971C	1481C		FZB	8:4
2	18004	CSK, CYL. SKALLE, TRUBBIG	7971F	1481F		FZB	8:2
3	18006	FSS, FÖRSÄNKT, SPETS	7972C	1482C		FZB	8:4
4	18007	FSK, FÖRSÄNKT, TRUBBIG	7972F	1482F		FZB	8:1
5	18010	KFSS, KULLERFÖRSÄNKT	7973C	1483C		FZB	8:4
6	18011	RXS, KULLRIG, SPETS, PH	7981C	7049C		FZB	8:1
7	18012	RXS, KULLRIG, SPETS, POZI	7981C	7049C		FZB	8:1
6	18013	RXS, KULLRIG, SPETS, PH	7981C	7049C		FZS	8:1
6	18016	RXS, KULLRIG, SPETS, PH	7981C	7049C		SVOX	8:1
8	18015	RTS, KULLRIG, SPETS, STAR	7981C	7049C		FZB	8:3
8	18017	RTS, KULLRIG, SPETS, STAR	7981C	7049C		SVOX	8:3
9	18020	RXK, KULLRIG, TRUBBIG, PH	7981F	7049F		FZB	8:2
10	18021	RXK, KULLRIG, TRUBBIG, POZI	7981F	7049F		FZB	8:2
11	18023	RTK, TRUBBIG, STAR	7981F	7049F		FZB	8:3
12	18030	FXS, FÖRSÄNKT, SPETS, PH	7982C	7050C		FZB	8:1
12	18036	FXS, FÖRSÄNKT, SPETS, PH ISO		7050C		FZB	8:1
13	18031	FXS, FÖRSÄNKT, SPETS, POZI	7982C	7050C		FZB	8:1
13	18037	FXS, FÖRSÄNKT, SPETS, POZI ISO		7050C		FZB	8:1
13	18033	FXS, FÖRSÄNKT, SPETS, PH	7982C	7050C		SVOX	8:1
14	18035	FTS, FÖRSÄNKT, SPETS, STAR	7982C	7050C		FZB	8:3
14	18038	FTS, FÖRSÄNKT, SPETS, STAR ISO		7050C		FZB	8:3
15	18040	KFXS, KULLERFÖRSÄNKT, PH	7983C	7051C		FZB	8:1
15	18046	KFXS, KULLERFÖRSÄNKT, PH ISO		7051C		FZB	8:1
15	18043	KFXS, KULLERFÖRSÄNKT, PH	7983C	7051C		SVOX	8:1
16	18041	KFXS, KULLERFÖRSÄNKT, POZI	7983C	7051C		FZB	8:1
16	18047	KFXS, KULLERFÖRSÄNKT, POZI ISO		7051C		FZB	8:1
17	18049	KFTS, KULLERFÖRSÄNKT, STAR	7983C	7051C		FZB	8:3
17	18048	KFTS, KULLERFÖRSÄNKT, STAR ISO		7051C		FZB	8:3
18	18050	BSS, 6-KANT, SPETSIG	7976C	1479C		FZB	8:5
19	18051	BSK, 6-KANT, TRUBBIG	7976F	1479F		FZB	8:5
20	18056	BSSF, 6-KANT MED FLÄNS + SPÅR				FZB	8:5
21	18060	RXB, KULLRIG, BORRSP., PH	7504N			FZB	8:6
22	18061	RXB, KULLRIG, BORRSP., POZI	7504N			FZB	8:6
23	18062	RTB, KULLRIG, BORRSP., STAR	7504N			FZB	8:14
24	18070	FXB, FÖRSÄNKT, PH	7504P			FZB	8:13
25	18071	FXB, FÖRSÄNKT, POZI	7504P			FZB	8:13

SWEBOLT AB

TEL. 08-584 909 60 FAX. 08-583 581 82

BILD	ART.GR.	BENÄMNING	DIN	ISO	KVAL	YTBEH	SIDA
26	18072	FTB, FÖRSÄNKT, STAR	7504P			FZB	8:14
27	18075	KFXB, KULLERFÖRSÄNKT, PH	7504Q			FZB	8:13
28	18076	KFXB, KULLERFÖRSÄNKT, POZI	7504Q			FZB	8:13
29	18077	KFTB, KULLERFÖRSÄNKT, STAR	7504Q			FZB	8:14
30	18080	HB-TEKS, SEXKANT, BORRSPETS	7504K			FZB	8:6
30	18081	HB-TEKS, SEXKANT, BORRSPETS	7504K			DURAL	8:6
31	18090	WING-TEKS, PH				FZB	8:7
	18091	WING-TEKS, STAR				FZB	8:7
32	18200	M6SF-TT, TAPTITE, SEXKANT	7500D			FZB	8:8
32	18207	M6S-TT, TAPTITE UTAN FLÄNS	7500D			FZB	8:8
33	18201	MC6S-TT, TAPTITE, INSEX	7500E			FZB	8:8
34	18205	MRX-TT, TAPTITE, KULLRIG	7500C			FZB	8:9
35	18210	MFXT-TT, TAPTITE, FÖRSÄNKT	7500M			FZB	8:9
36	18216	MFT-TT, TAPTITE, FÖRS., STAR	~7500M			FZB	8:10
37	18208	MRT-TT, TAPTITE, KULLRIG, STAR	~7500C			FZB	8:10
38	18240	MFTF-TT, FLAKSKRUV, STAR				FZB	8:10
39	18220	RXSF, KULLRIG MED FLÄNS	~7981			FZB	8:7
40	18300	M6SSG, GÄNGSKÄRANDE 6-KANT	7513A			OBEH	8:15
40	18301	M6SSG, GÄNGSKÄRANDE 6-KANT	7513A			FZB	8:15
41	18310	MCSSG, GÄNGSKÄRANDE, KULL.	7513B			OBEH	8:15
41	18311	MCSSG, GÄNGSKÄRANDE, KULL.	7513B			FZB	8:15
42	18320	MFSSG, GÄNGSKÄRANDE, FÖRS.	7513F			OBEH	8:16
42	18321	MFSSG, GÄNGSKÄRANDE, FÖRS.	7513F			FZB	8:16
43	18330	MKFSSG, GÄNGSKÄRANDE	7513G			OBEH	8:16
43	18331	MKFSSG, GÄNGSKÄRANDE	7513G			FZB	8:16
44	18336	ECSS, ENVÄGS, CYL-SKALLE				FZB	8:17
45	18340	LÅSSKRUV, CYL. SKALLE m. 2 HÅL				FZB	8:17
46	18343	LÅSSKRUV, FÖRSÄNKT SKALLE m. 2 HÅL				FZB	8:17
47	18351	BSSB, 6-KANT, SPETSIG, OFÖRFLORBAR BRICKA				FZB	8:18
48	18356	RXSB, KULLRIG SKALLE, OFÖRFLORBAR BRICKA				FZB	8:18
49	18361	RXS-GS, KULLRIG, GÄNGSKÄRANDE, PH			HV450	FZB	8:19
50	18366	MRX-GS, KULLRIG, GÄNGSKÄRANDE, PH			HV450	FZB	8:19
51	18371	MFS-GS, FÖRSÄNKT, GÄNGSKÄRANDE			HV450	FZB	8:20
52	18376	MCS-GS, KULLRIG, GÄNGSKÄRANDE			HV450	FZB	8:20
53	18381	M6S-GS, 6-KANT, GÄNGSKÄRANDE			HV450	FZB	8:21
54	18386	MRT-GS, KULLRIG, GÄNGSKÄRANDE, STAR			HV450	FZB	8:21

SWEBOLT AB

TEL. 08-584 909 60 FAX. 08-583 581 82

BILD	ART.GR.	BENÄMNING	DIN	ISO	KVAL	YTBEH	SIDA
55	18391	MKFT-GS, KULLERFÖRSÄNKT, GÄNGSKÄRANDE			HV450	FZB	8:21
56	18401	T-RXS, FÖR TERMOPLAST, KULLRIG				FZB	8:11
57	18406	T-FXS, FÖR TERMOPLAST, FÖRSÄNKT				FZB	8:22
58	18411	T-MCS, FÖR TERMOPLAST, CYLINDRISK				FZB	8:22
59	18416	T-M6S, FÖR TERMOPLAST, SEXKANT				FZB	8:23
60	18421	T-RTS, FÖR TERMOPLAST, KULLRIG, STAR				FZB	8:11
61	18426	T-KFTS, FÖR TERMOPLAST, KULLERÖRSÄNKT, STAR				FZB	8:23
62	18431	T-RXSF, FÖR TERMOPLAST, KULLRIG, FLÄNS, STAR				FZB	8:11
63	18441	RTS-COMBI, SPETS STAR+SPÅR				FZB	8:12
64	18443	RTK-COMBI, TRUBBIG STAR+SPÅR				FZB	8:12

ROSTFRITT / SYRAFAST

1	28000	CSS, CYL. SKALLE, SPETS	7971C	1481C	A2		8:41
1	28001	CSS, CYL. SKALLE, SPETS	7971C	1481C	A4		8:42
3	28005	FSS, FÖRSÄNKT, SPETS	7972C	1482C	A2		8:41
3	28006	FSS, FÖRSÄNKT, SPETS	7972C	1482C	A4		8:42
5	28009	KFSS, KULLERFÖRSÄNKT	7973C	1483C	A2		8:41
5	28010	KFSS, KULLERFÖRSÄNKT	7973C	1483C	A4		8:42
6	28011	RXS, KULLRIG, SPETS, PH	7981C	7049C	A2		8:43
7	28012	RXS, KULLRIG, SPETS, POZI	7981C	7049C	A2		8:43
6	28013	RXS, KULLRIG, SPETS, PH	7981C	7049C	A4		8:44
7	28014	RXS, KULLRIG, SPETS, POZI	7981C	7049C	A4		8:44
8	28015	RTS, KULLRIG, SPETS, STAR	7981C	7049C	A2		8:45
8	28016	RTS, KULLRIG, SPETS, STAR	7981C	7049C	A4		8:46
12	28030	FXS, FÖRSÄNKT, SPETS, PH	7982C	7050C	A2		8:43
12	28051	FXS, FÖRSÄNKT, SPETS, PH ISO		7050C	A2		8:43
12	28032	FXS, FÖRSÄNKT, SPETS, PH	7982C	7050C	A4		8:44
12	28036	FXS, FÖRSÄNKT, SPETS, PH ISO		7050C	A4		8:44
13	28031	FXS, FÖRSÄNKT, SPETS, POZI	7982C	7050C	A2		8:43
13	28052	FXS, FÖRSÄNKT, SPETS, POZI ISO		7050C	A2		8:43
13	28033	FXS, FÖRSÄNKT, SPETS, POZI	7982C	7050C	A4		8:44
13	28037	FXS, FÖRSÄNKT, SPETS, POZI ISO		7050C	A4		8:44
14	28034	FTS, FÖRSÄNKT, SPETS, STAR	7982C	7050C	A2		8:45
14	28053	FTS, FÖRSÄNKT, SPETS, STAR ISO		7050C	A2		8:45
14	28035	FTS, FÖRSÄNKT, SPETS, STAR	7982C	7050C	A4		8:46
14	28038	FTS, FÖRSÄNKT, SPETS, STAR ISO		7050C	A4		8:46
15	28040	KFXS, KULLERFÖRSÄNKT, PH	7983C	7051C	A2		8:43
15	28057	KFXS, KULLERFÖRSÄNKT, PH ISO		7051C	A2		8:43
15	28042	KFXS, KULLERFÖRSÄNKT, PH	7983C	7051C	A4		8:44
15	28046	KFXS, KULLERFÖRSÄNKT, PH ISO		7051C	A4		8:44

SWEBOLT AB

TEL. 08-584 909 60 FAX. 08-583 581 82

BILD	ART.GR.	BENÄMNING	DIN	ISO	KVAL	YTBEH	SIDA
16	28041	KFXS, KULLERFÖRSÄNKTK, POZI	7983C	7051C	A2		8:43
16	28058	KFXS, KULLERFÖRSÄNKTK, POZI ISO		7051C	A2		8:43
16	28043	KFXS, KULLERFÖRSÄNKTK, POZI	7983C	7051C	A4		8:44
16	28047	KFXS, KULLERFÖRSÄNKTK, POZI ISO		7051C	A4		8:44
17	28048	KFTS, KULLERFÖRSÄNKTK, STAR	7983C	7051C	A2		8:45
17	28059	KFTS, KULLERFÖRSÄNKTK, STAR ISO		7051C	A2		8:45
17	28049	KFTS, KULLERFÖRSÄNKTK, STAR	7983C	7051C	A4		8:46
17	28048	KFTS, KULLERFÖRSÄNKTK, STAR ISO		7051C	A4		8:46
18	28050	BSS, 6-KANT, SPETSIG	7976C	1479C	A2		8:49
	28054	BÅTSKRUV, CYLINDRISK			A4		8:51
21	28060	RXB, KULLRIG, BORRSPETS	7504N		A2		8:49
30	28080	HB-TEKS, SEXKANT, BORRSPETS	7504K		A2		8:49
32	28200	M6SF-TT, SEXKANT, TAPTITE	7500D		A2		8:48
34	28205	MRX-TT, KULLRIG, TAPTITE	7500C		A2		8:47
35	28210	MFXTT, FÖRSÄNKTK, TAPTITE	7500M		A2		8:47
44	28336	ECSS, ENVÄGS, CYL SKALLE			A2		8:50
45	28340	LÅSSKRUV, CYL. SKALLE m. 2 HÅL			A2		8:50
46	28343	LÅSSKRUV, FÖRSÄNKTK SKALLE m. 2 HÅL			A2		8:50
<u>ALUMINIUM</u>							
1	68000	CSS, CYL SKALLE, SPETS	7971C	1481			8:70

SWEBOLT AB

TEL. 08-584 909 60 FAX. 08-583 581 82

ARTIKELLISTA
2013-2014
PLÅTSKRUV
RXS FZB DIN 7981C

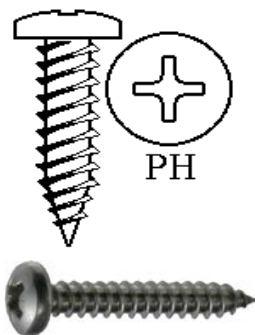

DIM	2.2	2.9	3.5	4.2	4.8	5.5	6.3
Skalld	4	5.6	6.9	8.2	9.5	10.8	12.5
Skallh	1.6	2.3	2.6	3.05	3.55	3.95	4.55
Längd	C:A PRIS/100 ST						
4.5	X						
6.5	X	X					
9.5	X	X	X	X	X		
13	X	X	X	X	X	X	X
16		X	X	X	X	X	X
19		X	X	X	X	X	X
25		X	X	X	X	X	X
32			X	X	X	X	X
38			X	X	X	X	X
45				X	X		
50				X	X	X	X
70					X		

BESTÄLLNINGSEXEMPEL: 180114225 - RXS 4.2X25 FZB PH

FXS FZB DIN 7982C

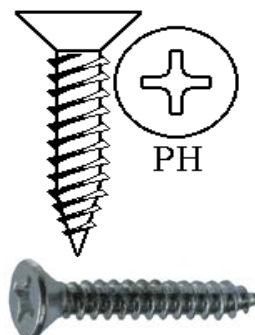

DIM	2.9	3.5	4.2	4.8	5.5	6.3
Skalld	5.6	6.9	8.2	9.5	11	12
Skallh	1.7	2.1	2.5	3	3.4	3.8
Längd	C:A PRIS/100 ST					
6.5	X					
9.5	X	X	X			
13	X	X	X		X	
16	X	X	X	X	X	
19		X	X	X	X	
22						
25		X	X	X	X	X
32		X	X	X	X	X
38			X	X	X	X
45						
50			X	X	X	X

BESTÄLLNINGSEXEMPEL: 180304232 - FXS 4.2X32 FZB PH

KFXS FZB DIN 7983C



DIM	2.9	3.5	4.2	4.8	5.5	6.3
Skalld	5.5	6.8	8.1	9.5	10.8	12.4
Skallh	1.7	2.1	2.5	3	3.4	3.8
Längd	C:A PRIS/100 ST					
6.5	X					
9.5	X	X	X			
13	X	X	X	X	X	
16	X	X	X	X	X	
19	X	X	X	X	X	X
22						
25		X	X	X	X	X
32		X	X	X	X	X
38			X	X	X	X
45				X		
50			X			X

BESTÄLLNINGSEXEMPEL: 180404238 - KFXS 4.2X38 FZB PH

ÖVRIGA DIMENSIONER OCH LÄNGDER MOT FÖRFRÅGAN !

FORP.	
200 ST	SAMTLIGA

SWEBOLT AB

TEL 08 - 555 975 00 FAX 08 - 583 581 82

ARTIKELLISTA

2013-2014

PLÅTSKRUV

RTS FZB DIN 7981C STAR

BLANKFÖRZINKAD

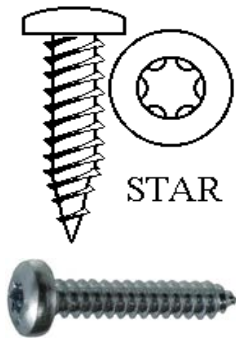

DIM	2.9	3.5	4.2	4.8	5.5	6.3
Skalld	5.6	6.9	8.2	9.5	10.8	12.5
Skallh	2.3	2.6	3.05	3.55	3.95	4.55
S-nyckel	T10	T10	T20	T25	T25	T30
Längd	C:A PRIS/100 ST					
6.5	X		X			
9.5	X	X	X	X		
13	X	X	X	X	X	X
16	X	X	X	X	X	
19		X	X	X	X	X
25		X	X	X	X	X
32			X	X	X	X
38			X			X
50				X		X

BESTÄLLNINGSEXEMPEL: 180154225 - RTS 4.2X25 FZB STAR

FTS FZB DIN 7982C STAR

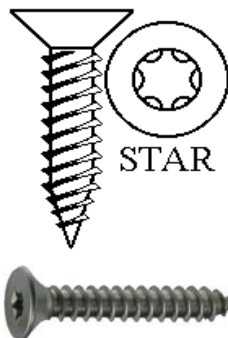

DIM	2.9	3.5	4.2	4.8	5.5	6.3
Skalld	5.6	6.9	8.2	9.5	11	12
Skallh	1.7	2.1	2.5	3	3.4	3.8
S-nyckel	T10	T10	T20	T25	T25	T30
Längd	C:A PRIS/100 ST					
6.5						
9.5						
13						
16						
19						
25						
32						
38						
50						

BESTÄLLNINGSEXEMPEL: 180234232 - FTS 4.2X32 FZB STAR

KFTS FZB DIN 7983C STAR

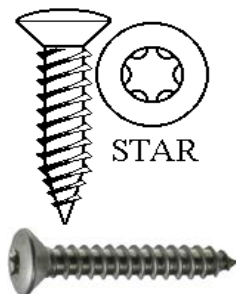

DIM	2.9	3.5	4.2	4.8	5.5	6.3
Skalld	5.6	6.9	8.2	9.5	10.8	12.5
Skallh	1.7	2.1	2.5	3	3.4	3.8
S-nyckel	T10	T10	T20	T25	T25	T30
Längd	C:A PRIS/100 ST					
6.5						
9.5						
13						
16						
19						
25						
32						
38						
50						

BESTÄLLNINGSEXEMPEL: 180494238 - KFTS 4.2X38 FZB STAR

ÖVRIGA DIMENSIONER OCH LÄNGDER MOT FÖRFRÅGAN !

FORP.	
200 ST	SAMTLIGA

BITS UNDER FLIK 18 !

SWEBOLT AB

TEL 08 - 555 975 00 FAX 08 - 583 581 82



ARTIKELLISTA
2013-2014
PLÅTSKRUV
BSS FZB DIN 7976C
BLANKFÖRZINKAD

DIM	2.9	3.5	4.2	4.8	5.5	6.3	8.0
Skallh	1.5	2.3	2.8	3	4	4.8	5.8
NV	5	5.5	7	8	8	10	13
Längd	C:A PRIS/100 ST						
6.5							
9.5							
13			X			X	
16			X	X		X	
19			X	X		X	X
25			X	X	X	X	X
32						X	X
38						X	X
50						X	
60							
70							
FÖRP.	2.9	3.5	4.2	4.8	5.5	6.3	8.0
500 ST	6.5-	6.5-	13-	19-			
200 ST					13-	13-	19-

BESTÄLLNINGSEXEMPEL: 180504819 - BSS ST4.8X19 FZB

SWEBOLT AB

TEL 08 - 555 975 00 FAX 08 - 583 581 82

ARTIKELLISTA

2013-2014
PLÅTSKRUV

RXB FZB DIN 7504N PH

DIM	3.5	4.2	4.8	5.5	6.3
Skalld	6.9	8.2	9.5	10.8	12.5
Skallh	2.6	3.05	3.55	3.95	4.55
Längd	C:A PRIS / 100 ST				
9.5	X				
13	X	X	X		
16	X	X	X		
19	X	X	X	X	
22			X		
25	X	X	X	X	X
32		X	X	X	
38		X	X		X
45					X
50			X		X

BESTÄLLNINGSEXEMPEL: 180603513 - RXB ST3.5X13 FZB PH



HB-TEKS DELTA DIN 7504K

DIM	3.5	4.2	4.8	5.5	6.3
Flänsd	8.3	8.8	10.5	11	13.2
Skallh	3.45	4.25	4.45	5.45	6.45
NV	5.5	7	8	8	10
Längd	C:A PRIS / 100 ST				
13		X	X		X
16		X	X	X	
19		X	X	X	X
22					X
25		X	X	X	X
32		X	X	X	X
38		X	X	X	X
45				X	
50		X	X	X	X

BESTÄLLNINGSEXEMPEL: 180825525 - HB-TEKS ST5.5X25 DELTA



HB-TEKS FZB DIN 7504K

DIM	3.5	4.2	4.8	5.5	6.3
Flänsd	8.3	8.8	10.5	11	13.2
Skallh	3.45	4.25	4.45	5.45	6.45
NV	5.5	7	8	8	10
Längd	C:A PRIS / 100 ST				
9.5	X				
13	X	X	X		
16	X	X	X	X	
19	X	X	X	X	X
22		X	X		X
25	X	X	X	X	X
32		X	X	X	X
38			X	X	X
45			X	X	X
50			X	X	X

BESTÄLLNINGSEXEMPEL: 180805525 - HB-TEKS ST5.5X25 FZB



FÖRP.	3.5	4.2	4.8	5.5	6.3
1000 ST	9.5-	13-	13-		
500 ST			45-	19-	19-
250 ST					38-

SWEBOLT AB

TEL 08 - 555 975 00 FAX 08 - 583 581 82

ARTIKELLISTA
2013-2014
TAPETITE SKRUV
M6SF-TT HÄRDAD FZB
DIN 6921 8.8 FZB



DIM	M3	M4	M5	M6	M8	M10
NV	5	7	8	10	12	14
Skallh	3	3.5	5	6.5	8.2	10
Fläns D	7	9.5	11	13.8	17.7	21.6
G-längd				18	22	26
Längd	C:A PRIS/100ST					
6						
8		X				
10		X	X	X		
12		X	X	X		
14						
16		X	X	X	X	
20		X	X	X	X	X
25		X	X	X	X	X
30		X	X	X	X	X
35						
40			X	X	X	X
45						
50				X	X	X
55						
60						

BESTÄLLNINGSEXEMPEL: 1820010030 - M6SF-TT M10x30 FZB

FÖRP.	M3	M4	M5	M6	M8	M10
500 ST	6-	8-				
200 ST			10-	10-	16-	20-
100 ST						30-

MC6S-TT HÄRDAD FZB

DIM	M3	M4	M5	M6	M8	M10
Ytterd		7	8.5	10	13	16
Insex		3	4	5	6	8
Skallh		4	5	6	8	10
Längd	C:A PRIS/100ST					
6						
8						
10						
12			X	X		
14						
16			X	X	X	
20			X	X	X	
25			X	X	X	
30			X	X	X	
35						
40						
45						X

BESTÄLLNINGSEXEMPEL: 1820106016 - MC6S-TT M6x16 FZB

ÖVRIGA DIMENSIONER OCH LÄNGDER MOT FÖRFRÅGAN !

FÖRP.	M3	M4	M5	M6	M8	M10
500 ST			12-	10-		
200 ST				20-	16-	

SWEBOLT AB

TEL 08 - 555 975 00 FAX 08 - 583 581 82



ARTIKELLISTA
2013-2014
TAPTITESKRUV
MRX-TT FZB DIN 7500C



DIM	M2.5	M3	M4	M5	M6
Skalld	5	6	8	10	12
Skallh	2	2.4	3.1	3.8	4.6
LÄNGD	C:A PRIS / 100 ST				
4	X				
5					
6		X	X	X	
8			X		
10		X	X	X	X
12		X	X	X	X
16		X	X	X	X
20		X	X	X	X
25		X	X		X
30					X
35					
40				X	X
45					
50					

BESTÄLLNINGSEXEMPEL: 1820504006 - MRX-TT M4X6 FZB

TAPTITE SKRUV
MFX-TT FZB



DIM	M2.5	M3	M4	M5	M6
Skalld	4.7	5.6	7.4	9.2	11
Skallh	1.2	1.65	2.2	2.5	3
Längd	C:A PRIS/100 ST				
6	X	X			
8		X	X		
10		X	X	X	
12		X	X	X	
16		X	X	X	X
20					X
25					X
30					X
35					
40				X	
45					
50					

BESTÄLLNINGSEXEMPEL: 1821005012 - MFX-TT M5X12 FZB

FÖRP	M2.5	M3	M4	M5	M6
500 ST	6-	5-	6-	8-	
200 ST					10-

ÖVRIGA DIMENSIONER OCH LÄNGDER MOT FÖRFRÅGAN !

SWEBOLT AB

TEL 08 - 555 975 00 FAX 08 - 583 581 82

ARTIKELLISTA
2013-2014
TAPTITESKRUV
MRT-TT FZB DIN 7500C

DIM	M2.5	M3	M4	M5	M6
Skalld	5	6	8	10	12
Skallh	2	2.4	3.1	3.8	4.6
NYCKEL	T-8	T-10	T-20	T-25	T-30
LÄNGD	C:A PRIS / 100 ST				
5		X			
6	X	X	X		
8		X	X	X	X
10		X	X	X	X
12	X	X	X	X	X
16	X	X	X	X	X
20			X	X	X
25			X	X	X
30			X	X	X
35				X	
40			X	X	X
45					
50					X



BESTÄLLNINGSEXEMPEL: 1820804006 - MRT-TT M4X6 FZB

TAPTITE SKRUV
MFT-TT FZB

DIM	M2.5	M3	M4	M5	M6
Skalld	4.7	5.6	7.4	9.2	11
Skallh	1.2	1.65	2.2	2.5	3
NYCKEL	T-8	T-10	T-20	T-25	T-30
Längd	C:A PRIS/100 ST				
6	X				
8			X		
10			X		
12			X	X	
16			X	X	X
20		X		X	X
25				X	X
30				X	X
35					
40				X	X
45					
50					X



BESTÄLLNINGSEXEMPEL: 1821605012 - MFT-TT M5X12 FZB

FÖRP	M2.5	M3	M4	M5	M6
500 ST	6-	8-	8-	12-	
200 ST					12-

ÖVRIGA DIMENSIONER OCH LÄNGDER MOT FÖRFRÅGAN !

BITS UNDER FLIK 18 !

SWEBOLT AB

TEL 08 - 555 975 00 FAX 08 - 583 581 82

ARTIKELLISTA
2013-2014
PLÅTSKRUV
CSS A4 DIN 7971C

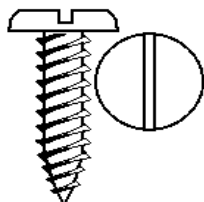

DIM	2.9	3.5	4.2	4.8	5.5	6.3
Skalld	5.6	6.9	8.2	9.5	10.8	12.5
Skallh	1.5	1.85	2.15	2.5	2.85	3.3
Längd	C:A PRIS/100 ST					
6.5						
9.5		X				
13		X				
16	X	X			X	
19		X	X			
25		X	X		X	
32			X	X	X	
38						
50						
60						
70						

BESTÄLLNINGSEXEMPEL: 280014232 - CSS 4.2X32 A4

FÖRP.	
200 ST	SAMTLIGA

BITS UNDER FLIK 18 !

ÖVRIGA DIMENSIONER OCH LÄNGDER MOT FÖRFRÅGAN !

SWEBOLT AB

TEL 08 - 555 975 00 FAX 08 - 583 581 82

ARTIKELLISTA

2013-2014

PLÅTSKRUV

RXS A2 DIN 7981C PHILLIPS

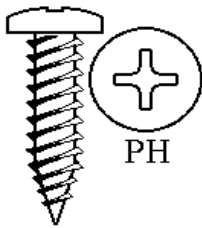

DIM	2.9	3.5	4.2	4.8	5.5	6.3
Skalld	5.6	6.9	8.2	9.5	10.8	12.5
Skallh	2.3	2.6	3.05	3.55	3.95	4.55
Längd	C:A PRIS/100 ST					
6.5	X					
9.5	X	X	X	X		
13	X	X	X	X	X	
16	X	X	X	X	X	X
19	X	X	X	X	X	X
25	X	X	X	X	X	X
32		X	X	X	X	X
38		X	X	X	X	X
50			X	X	X	X
60			X	X	X	
70			X	X	X	

BESTÄLLNINGSEXEMPEL: 280113519 - RXS ST3.5X19 A2 PH

FXS A2 DIN 7982C PHILLIPS

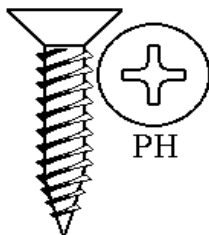

DIM	2.9	3.5	4.2	4.8	5.5	6.3
Skalld	5.5	6.8	8.1	9.5	10.8	12.4
Skallh	1.7	2.1	2.5	3	3.4	3.8
Längd	C:A PRIS/100 ST					
9.5	X	X				
13	X	X	X	X	X	
16	X	X	X	X	X	X
19	X	X	X	X	X	X
25	X	X	X	X	X	X
32		X	X	X	X	X
38		X	X	X	X	X
50			X	X	X	X
60			X			
70			X			

BESTÄLLNINGSEXEMPEL: 280303513 - FXS ST3.5X13 A2 PH

KFXS A2 DIN 7983C PHILLIPS

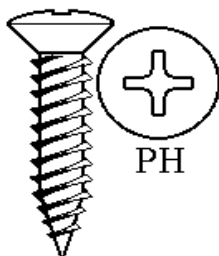

DIM	2.9	3.5	4.2	4.8	5.5	6.3
Skalld	5.6	6.9	8.2	9.5	10.8	12.5
Skallh	1.7	2.1	2.5	3	3.4	3.8
Längd	C:A PRIS/100 ST					
6.5	X					
9.5	X	X				
13	X	X	X	X	X	
16	X	X	X	X	X	X
19	X	X	X	X	X	X
25	X	X	X	X	X	X
32		X	X	X	X	X
38		X	X	X	X	X
50			X	X	X	X

BESTÄLLNINGSEXEMPEL: 280403525 - KFXS ST3.5X25 A2 PH

FÖRP.
200 ST

SAMTLIGA

BITS UNDER FLIK 18 !

ÖVRIGA DIMENSIONER OCH LÄNGDER MOT FÖRFRÅGAN !

SWEBOLT AB

TEL 08 - 555 975 00 FAX 08 - 583 581 82

ARTIKELLISTA
2013-2014
PLÅTSKRUV
RXS A4 DIN 7981C POZI
SYRAFAST

DIM	2.9	3.5	4.2	4.8	5.5	6.3
Skalld	5.6	6.9	8.2	9.5	10.8	12.5
Skallh	2.3	2.6	3.05	3.55	3.95	4.55
Längd	C:A PRIS/100 ST					
6.5	X					
9.5	X	X	X	X		
13	X	X	X	X	X	X
16	X	X	X	X	X	X
19	X	X	X	X	X	X
25	X	X	X	X	X	X
32		X	X	X	X	X
38		X	X	X	X	X
50			X	X	X	X



BESTÄLLNINGSEXEMPEL: 280145525 - RXS ST5.5X25 A4 POZI

FXS A4 DIN 7982C POZI

DIM	2.9	3.5	4.2	4.8	5.5	6.3
Skalld	5.5	6.8	8.1	9.5	10.8	12.4
Skallh	1.7	2.1	2.5	3	3.4	3.8
Längd	C:A PRIS/100 ST					
9.5	X	X	X			
13	X	X	X	X	X	
16	X	X	X	X	X	X
19	X	X	X	X	X	X
25	X	X	X	X	X	X
32		X	X	X	X	X
38		X	X	X	X	X
50			X	X	X	X



BESTÄLLNINGSEXEMPEL: 280335525 - FXS ST5.5X25 A4 POZI

KFXS A4 DIN 7983C POZI

DIM	2.9	3.5	4.2	4.8	5.5	6.3
Skalld	5.5	6.8	8.1	9.5	10.8	12.4
Skallh	1.7	2.1	2.5	3	3.4	3.8
Längd	C:A PRIS/100 ST					
9.5	X	X				
13	X	X	X	X	X	
16	X	X	X	X	X	X
19	X	X	X	X	X	X
25	X	X	X	X	X	X
32		X	X	X	X	X
38		X	X	X	X	X
50			X	X	X	X



BESTÄLLNINGSEXEMPEL: 280435525 - KFXS ST5.5X25 A4 POZI

FÖRP.	
200 ST	SAMTLIGA

ÖVRIGA DIMENSIONER OCH LÄNGDER MOT FÖRFRÅGAN !

SWEBOLT AB

TEL 08 - 555 975 00 FAX 08 - 583 581 82

ARTIKELLISTA
2013-2014
PLÅTSKRUV
RTS A2 DIN 7981C STAR
ROSTFRI

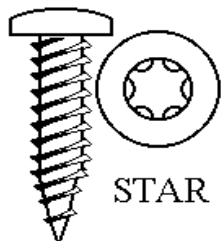

DIM	2.9	3.5	4.2	4.8	5.5	6.3
Skalld	5.6	6.9	8.2	9.5	10.8	12.5
Skallh	2.3	2.6	3.05	3.55	3.95	4.55
S-nyckel	T10	T10	T20	T25	T25	T30
Längd	C:A PRIS/100 ST					
6.5	X					
9.5	X	X	X			
13	X	X	X	X	X	
16	X	X	X	X	X	X
19	X	X	X	X	X	X
25	X	X	X	X	X	X
32		X	X	X	X	X
38		X	X	X	X	X
50			X	X	X	X
60						
70			X			

BESTÄLLNINGSEXEMPEL: 280154225 - RTS 4.2X25 A2 STAR

FTS A2 DIN 7982C STAR

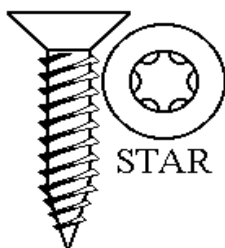

DIM	2.9	3.5	4.2	4.8	5.5	6.3
Skalld	5.6	6.9	8.2	9.5	11	12
Skallh	1.7	2.1	2.5	3	3.4	3.8
S-nyckel	T10	T10	T20	T25	T25	T30
Längd	C:A PRIS/100 ST					
6.5						
9.5	X	X				
13	X	X	X	X	X	
16	X	X	X	X	X	X
19	X	X	X	X	X	X
25	X	X	X	X	X	X
32		X	X	X	X	X
38		X	X	X	X	X
50			X	X	X	X

BESTÄLLNINGSEXEMPEL: 28034 4232 - FTS 4.2X32 A2 STAR

KFTS A2 DIN 7983C STAR

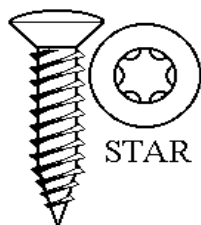

DIM	2.9	3.5	4.2	4.8	5.5	6.3
Skalld	5.6	6.9	8.2	9.5	10.8	12.5
Skallh	1.7	2.1	2.5	3	3.4	3.8
S-nyckel	T10	T10	T20	T25	T25	T30
Längd	C:A PRIS/100 ST					
6.5						
9.5	X	X				
13	X	X	X	X	X	
16	X	X	X	X	X	X
19	X	X	X	X	X	X
25	X	X	X	X	X	X
32		X	X	X	X	X
38		X	X	X	X	X
50			X	X	X	X

BESTÄLLNINGSEXEMPEL: 280484238 - KFTS 4.2X38 A2 STAR

ÖVRIGA DIMENSIONER OCH LÄNGDER MOT FÖRFRÅGAN !

FORP.	
200 ST	SAMTLIGA

SWEBOLT AB

TEL 08 - 555 975 00 FAX 08 - 583 581 82

ARTIKELLISTA
2013-2014
PLÅTSKRUV
RTS A4 DIN 7981C STAR
SYRAFAST

DIM	2.9	3.5	4.2	4.8	5.5	6.3
Skalld	5.6	6.9	8.2	9.5	10.8	12.5
Skallh	2.3	2.6	3.05	3.55	3.95	4.55
S-nyckel	T10	T10	T20	T25	T25	T30
Längd	C:A PRIS/100 ST					
6.5	X					
9.5	X	X	X	X		
13	X	X	X	X	X	X
16	X	X	X	X	X	X
19	X	X	X	X	X	X
25	X	X	X	X	X	X
32		X	X	X	X	X
38		X	X	X	X	X
50			X	X	X	X

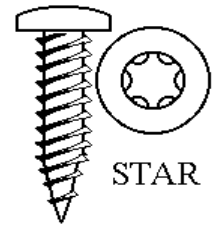

BESTÄLLNINGSEXEMPEL: 280165516 - RTS 5.5X16 A4 STAR

FTS A4 DIN 7982C STAR

DIM	2.9	3.5	4.2	4.8	5.5	6.3
Skalld	5.6	6.9	8.2	9.5	10.8	12.5
Skallh	1.7	2.1	2.5	3	3.4	3.8
S-nyckel	T10	T10	T20	T25	T25	T30
Längd	C:A PRIS/100 ST					
9.5	X	X	X			
13	X	X	X	X	X	
16	X	X	X	X	X	X
19	X	X	X	X	X	X
25	X	X	X	X	X	X
32		X	X	X	X	X
38		X	X	X	X	X
50			X	X	X	X

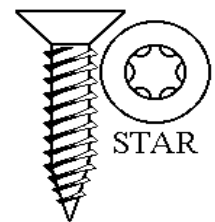

BESTÄLLNINGSEXEMPEL: 280352925 - FTS 2.9X25 A4 STAR

KFTS A4 DIN 7983C STAR

DIM	2.9	3.5	4.2	4.8	5.5	6.3
Skalld	5.6	6.9	8.2	9.5	10.8	12.5
Skallh	1.7	2.1	2.5	3	3.4	3.8
S-nyckel	T10	T10	T20	T25	T25	T30
Längd	C:A PRIS/100 ST					
9.5	X	X				
13	X	X	X	X	X	
16	X	X	X	X	X	X
19	X	X	X	X	X	X
25	X	X	X	X	X	X
32		X	X	X	X	X
38		X	X	X	X	X
50			X	X	X	X

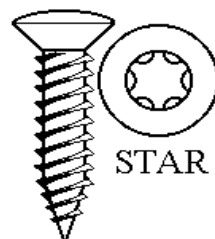

BESTÄLLNINGSEXEMPEL: 280494819 - KFTS 4.8X19 A4 STAR

ÖVRIGA DIMENSIONER OCH LÄNGDER MOT FÖRFRÅGAN !

FÖRP.	
200 ST	SAMTLIGA

BITS UNDER FLIK 18 !

SWEBOLT AB
TEL 08 - 555 975 00 FAX 08 - 583 581 82

ARTIKELLISTA
2013-2014
PLÅTSKRUV
HB-TEKS DIN 7504K A2
ROSTFRI

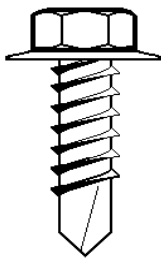

DIM	3.9	4.2	4.8	5.5	6.3
Skallh	3.1	3.6	4.1	4.8	5.8
NV	7	7	8	8	10
Längd	C:A PRIS/100 ST				
6.5					
9.5					
13		X	X		
16			X		
19			X	X	
25			X	X	
32			X	X	
42				X	
50			X		
60					
70					









BESTÄLLNINGSEXEMPEL: 280805525 - HB-TEKS 5.5x25 A2

ÖVRIGA DIMENSIONER OCH LÄNGDER MOT FÖRFRÅGAN !

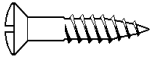
FÖRP	3.9	4.2	4.8	5.5	6.3
1000ST	9.5-	13-	13-		
500ST		25-	25-	19-	
200ST				32-	

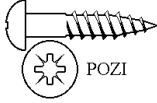
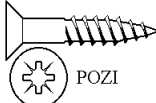
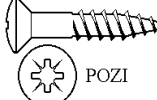
SWEBOLT AB

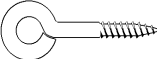
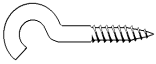
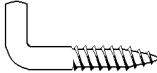
TEL 08 - 555 975 00 FAX 08 - 583 581 82

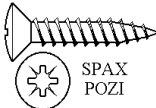
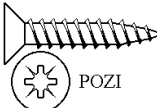
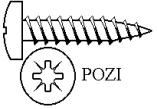
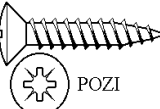
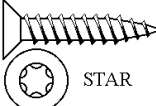
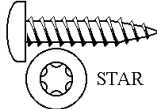
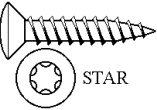
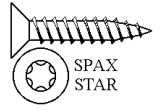
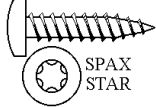
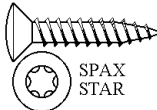
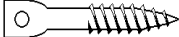
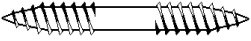
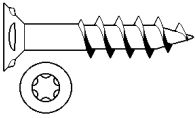
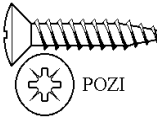
- 1 - 	- 2 - 	- 3 - 	- 4 - 
- 5 - 	- 6 - 	- 7 - 	- 8 - 
- 9 - 	- 10 - 	- 11 - 	- 12 - 
- 13 - 	- 14 - 	- 15 - 	- 16 - 
- 17 - 	- 18 - 	- 19 - 	- 20 - 
- 21 - 	- 22 - 	- 23 - 	- 24 - 
- 25 - 	- 26 - 	- 27 - 	- 28 - 
- 29 -	- 30 -	- 31 -	- 32 -

SWEBOLT AB

TEL. 08-584 909 60 FAX. 08-583 581 82

PRODUKTER I STÅL

1	19000	TKS, KULLRIG SKALLE	96	UTGÅR	OBEH	
1	19001	TKS, KULLRIG SKALLE	96	UTGÅR	FZB	
2	19005	TFS, FÖRSÄNKT	97	UTGÅR	OBEH	
2	19006	TFS, FÖRSÄNKT	97	UTGÅR	FZB	
3	19010	TKFS, KULLERFÖRSÄNKT	95	UTGÅR	OBEH	
3	19011	TKFS, KULLERFÖRSÄNKT	95	UTGÅR	FZB	
4	19020	T6S, 6-KANT TRÄSKRUV	571		OBEH	9:1
4	19021	T6S, 6-KANT TRÄSKRUV	571		FZB	9:1
4	19022	T6S, 6-KANT TRÄSKRUV	571		FZV	9:1
5	19101	T6SF, 6-KANT m. FLÄNS			FZB	9:1
5	19102	T6SF, 6-KANT m. FLÄNS			FZV	9:1
6	19026	TRX, KULLRIG, POZI	7996		FZB	9:9
7	19031	TFX, FÖRSÄNKT, POZI	7997		FZB	9:9
8	19036	TKFX, KULLERFÖRSÄNKT, POZI	7995		FZB	9:9
9	19040	LSS, LEDSTÅNGSSKRUV			OBEH	9:10
9	19041	LSS, LEDSTÅNGSSKRUV			FZB	9:10
10	19050	ÖST, ÖGLESKRUV, TRÄGÄNGA			OBEH	9:10
10	19051	ÖST, ÖGLESKRUV, TRÄGÄNGA			FZB	9:10
10	19053	ÖSTÖ. FÖRANKRINGSÖGLA SVETSAD			OBEH	
10	19054	ÖSTÖ, FÖRANKRINGSÖGLA SVETSAD			FZB	
11	19060	RK, RUNDKROK, TRÄGÄNGA			OBEH	9:10
11	19061	RK, RUNDKROK, TRÄGÄNGA			FZB	9:10
12	19070	VK, VINKELKROK, TRÄGÄNGA			OBEH	9:11
12	19071	VK, VINKELKROK, TRÄGÄNGA			FZB	9:11
12	19073	VKK, VINKELKROK, KRAFTIG, TRÄGÄNGA			FZB	9:11
13	19324	TFXD-S, FÖRSÄNKT DELGÄNGAD, SPAX			FZB	9:8
13	19325	TFX-S, FÖRSÄNKT, SPAX, POZI			FZB	9:7
14	19326	TKX-S, KULLRIG, SPAX, POZI			FZB	9:7
15	19327	TKFX-S, KULLERFÖRS., SPAX, POZI			FZB	9:7
15	19328	TKFX-S, KULLERFÖRS, SPAX, POZI			FÖRNICKLAD	9:7
16	19311	UFX, FÖRSÄNKT, POZI			FZB	9:3
17	19301	UKX, KULLRIG, POZI			FZB	9:2
18	19321	UKFX, KULLERFÖRSÄNKT, POZI			FZB	9:4
19	19341	UFT, FÖRSÄNKT, STAR			FZB	9:5
20	19351	UKT, KULLRIG, STAR			FZB	9:5
21	19361	UKFT, KULLERFÖRSÄNKT, STAR			FZB	9:4

BILD	ART.GR.	BENÄMNING	DIN	ISO	KVAL	YTBEH	SIDA
17	19303	AUKX, ALFASKRUV KULLRIG, POZI				FZB	9:4
17	19304	AUKT, ALFASKRUV KULLRIG, STAR				FZB	9:6
16	19313	AUFX, ALFASKRUV FÖRSÄNKT, POZI				FZB	9:5
16	19314	AUFT, ALFASKRUV FÖRSÄNKT, STAR				FZB	9:7
18	19343	AUKFX, ALFASKRUV KULLERFÖRSÄNKT, POZI				FZB	
18	19344	AUKFT, ALFASKRUV KULLERFÖRSÄNKT, STAR				FZB	
22	19371	TFTD-S, FÖRSÄNKT, SPAX, STAR				FZB	9:8
23	19372	TKT-S, KULLRIG, SPAX, STAR				FZB	9:12
24	19373	TKFT-S, KULLERF., SPAX, STAR				FZB	9:12
25	19380	BST, BLADSKRUV, TRÄGÄNGA				OBEH	9:13
25	19381	BST, BLADSKRUV, TRÄGÄNGA				FZB	9:13
26	19390	DLSS, DUBBEL LEDSTÅNGSSKRUV				OBEH	9:13
26	19391	DLSS, DUBBEL LEDSTÅNGSSKRUV				FZB	9:13

ROSTFRITT / SYRAFAST

1	29000	TKS, KULLRIG SKALLE	96		A2		9:53
1	29001	TKS, KULLRIG SKALLE	96		A4		9:54
2	29005	TFS, FÖRSÄNKT	97		A2		9:53
2	29006	TFS, FÖRSÄNKT	97		A4		9:54
3	29010	TKFS, KULLERFÖRSÄNKT	95		A2		9:53
3	29011	TKFS, KULLERFÖRSÄNKT	95		A4		9:54
4	29020	T6S, 6-KANT TRÄSKRUV	571		A2		9:40
4	29021	T6S, 6-KANT TRÄSKRUV	571		A4		9:40
6	29025	TRX, KULLRIG, POZI	7996		A2		9:55
6	29026	TRX, KULLRIG, POZI	7996		A4		9:56
7	29030	TFX, FÖRSÄNKT, POZI	7997		A2		9:55
7	29031	TFX, FÖRSÄNKT, POZI	7997		A4		9:56
8	29035	TKFX, KULLERFÖRSÄNKT, POZI	7995		A2		9:55
8	29036	TKFX, KULLERFÖRSÄNKT, POZI	7995		A4		9:56
10	29050	ÖST, ÖGLESKRUV, TRÄGÄNGA			A2		9:57
16	29311	UFX, FÖRSÄNKT, POZI			A2		9:41
16	29312	UFX, FÖRSÄNKT, POZI			A4		9:42
17	29301	UKX, KULLRIG, POZI			A2		9:43
17	29302	UKX, KULLRIG, POZI			A4		9:44
18	29320	UKFX, KULLERFÖRSÄNKT, POZI			A2		9:45
18	29321	UKFX, KULLERFÖRSÄNKT, POZI			A4		9:46
19	29340	UFT, FÖRSÄNKT, STAR			A2		9:47
19	29341	UFT, FÖRSÄNKT, STAR			A4		9:48

SWEBOLT AB

TEL. 08-584 909 60 FAX. 08-583 581 82

BILD	ART.GR.	BENÄMNING	DIN	ISO	KVAL	YTBEH	SIDA
20	29350	UKT, KULLRIG, STAR			A2		9:49
20	29351	UKT, KULLRIG, STAR			A4		9:50
21	29360	UKFT, KULLERFÖRSÄNKT, STAR			A2		9:51
21	29361	UKFT, KULLERFÖRSÄNKT, STAR			A4		9:52
27	215136	TRALLSKRUV, STAR			A4		9:56
28	29322	UKFX-P, VVS-SKRUV POLERAD			A2		9:57

MÄSSING

1	39000	TKS, KULLRIG SKALLE	96				9:60
1	39001	TKS, KULLRIG SKALLE	96			FÖRNICKLND	9:60
2	39005	TFS, FÖRSÄNKT	97				9:60
2	39006	TFS, FÖRSÄNKT	97			FÖRNICKLAD	9:60
3	39011	TKFS, KULLERFÖRSÄNKT	95				9:60
3	39012	TKFS, KULLERFÖRSÄNKT	95			FÖRNICKLAD	9:60
6	39025	TRX, KULLRIG, POZI	7996				9:61
6	39026	TRX, KULLRIG, POZI	7996			FÖRNICKLAD	9:61
7	39030	TFX, FÖRSÄNKT, POZI	7997				9:61
7	39031	TFX, FÖRSÄNKT, POZI	7997			FÖRNICKLAD	9:61
8	39035	TKFX, KULLERFÖRSÄNKT, POZI	7995				9:61
8	39036	TKFX, KULLERFÖRSÄNKT, POZI	7995			FÖRNICKLAD	9:61
10	39050	ÖST, ÖGLESKRUV, TRÄGÄNGA					9:62

SWEBOLT AB

TEL. 08-584 909 60 FAX. 08-583 581 82



ARTIKELLISTA
2013-2014
TRÄSKRUV 6-KANT
VARMFÖRZINKAD
T6S FZV DIN 571

DIM	6	8	10	12	16	20
NV	10	13	17	19	24	30
Skallh	4	5.5	7	8	10	13
Längd	C:A PRIS/100 ST					
25	X	X	X			
30	X	X	X			
35	X	X				
40	X	X	X	X		
45	X	X				
50	X	X	X	X		
55		X				
60	X	X	X	X		
65	X	X	X	X		
70	X	X	X	X		
75	X	X	X	X	X	
80	X	X	X	X	X	
90	X	X	X	X		
100	X	X	X	X	X	X
110						
120	X	X	X	X	X	
130		X	X			
140	X	X	X	X	X	
150	X	X	X	X	X	
160		X	X	X	X	
180		X	X	X	X	
200		X	X	X	X	
220			X	X		
240			X	X		
260			X	X		
280			X	X		
300			X	X	X	
360				X		

BESTÄLLNINGSEXEMPEL: 1902210050 - T6S 10X50 FZV

FÖRP.	6	8	10	12	16	20
200 ST	25-					
100 ST	100-	25-	25-			
50 ST			120-	50-		
25 ST					75-	100-

BLANKFÖRZINKAD
T6S FZB DIN 571



DIM	6	8	10	12	16	20
Längd	C:A PRIS/100 ST					
50						
60						
70						
75						

ÖVRIGA DIMENSIONER OCH LÄNGDER MOT FÖRFRÅGAN !

FÖRP.	6	8	10	12	16	20
200 ST		50-				

TRÄSKRUV MED FLÄNS BLANKFÖRZINKAD

7 x 40 = 124,- 7 x 50 = 129,-

SWEBOLT AB

TEL 08 - 555 975 00 FAX 08 - 583 581 82



ARTIKELLISTA
2013-2014
UNIVERSALSKRUV KULLRIG
UKX FZB
BLANKFÖRZINKAD

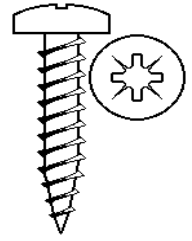

S=SMÅPACK

B=BULK (GRÅTT FÄLT)

DIM	2.5	2.5	3	3	3.5	3.5	4	4	4.5	4.5	5	5	6	6
Skalld	4.6	4.6	6	6	7	7	8	8	9	9	10	10	12	12
Skallh			2.2	2.2	2.6	2.6	3	3	3.6	3.6	4	4	4.5	4.5
FÖRP.	S	B	S	B	S	B	S	B	S	B	S	B	S	B
Längd	C:A PRIS/100 ST													
10			X											
12			X	X	X	X	X	X						
15					X	X	X	X						
16			X	X	X	X	X	X	X		X	X		
20			X	X	X		X	X	X		X			
25			X	X	X		X	X	X	X	X			
30			X	X	X		X	X	X	X	X		X	X
35			X		X	X	X	X	X	X	X	X	X	X
40			X		X	X	X	X	X		X		X	X
45							X	X	X		X		X	
50							X	X	X	X	X	X	X	X
55														
60							X	X	X	X	X		X	X
70											X		X	
80											X		X	
90											X		X	
100											X		X	

ÖVRIGA DIMENSIONER OCH LÄNGDER MOT FÖRFRÅGAN !

FÖRP.	2.5	B	3	B	3.5	B	4	B	4.5	B	5	B	6	B
200 ST	10-		10-		12-		12-		16-		16-		30-	

VI LEVERERAR ÄVEN ABC-SPAX ORIGINAL MOT FÖRFRÅGAN !

BESTÄLLNINGSEXEMPEL: 1930140020 - UKX 4.0X20 FZB POZI

BESTÄLLNINGSEXEMPEL: 19301400201 - UKX 4.0X20 FZB POZI *BULK*

BITS UNDER FLIK 18 !

SWEBOLT AB

TEL 08 - 555 975 00 FAX 08 - 583 581 82

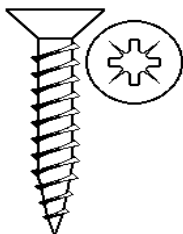

ARTIKELLISTA

2013-2014

UNIVERSALSKRUV FÖRSÄNKT

UFX FZB

BLANKFÖRZINKAD



S=SMÅPACK

B=BULK (GRÅTT FÄLT)

DIM	2.5	2.5	3	3	3.5	3.5	4	4	4.5	4.5	5	5	6	6
Skalld	4.6	4.6	6	6	7	7	8	8	9	9	10	10	12	12
Skallh			1.9	1.9	2.1	2.1	2.5	2.5	2.7	2.7	3	3	3.6	3.6
FÖRP.	S	B	S	B	S	B	S	B	S	B	S	B	S	B
Längd	C:A PRIS/100 ST													
10	X		X											
12	X		X	X	X	X	X	X						
15			X	X	X	X	X	X						
16	X		X	X	X	X	X	X	X	X	X			
20	X		X	X	X	X	X	X	X	X	X	X		
25	X		X	X	X	X	X	X	X	X	X	X		
30			X	X	X	X	X	X	X	X	X	X	X	X
35			X	X	X	X	X	X	X	X	X		X	X
40			X	X	X	X	X	X	X	X	X	X	X	X
45			X		X		X	X	X		X		X	
50			X		X		X	X	X	X	X		X	
55											X		X	
60							X	X	X		X	X	X	
70							X	X	X	X	X	X	X	X
80									X	X	X	X	X	
90											X		X	X
100											X		X	
110													X	
120											X		X	
130													X	
140													X	
150													X	
160													X	
180														
200														

ÖVRIGA DIMENSIONER OCH LÄNGDER MOT FÖRFRÅGAN !

FÖRP.	2.5	B	3	B	3.5	B	4	B	4.5	B	5	B	6	B
200 ST	10-		10-		12-		12-		12-		16-		30-	
100 ST											50-		50-	

VI LEVERERAR ÄVEN ABC-SPAX ORIGINAL MOT FÖRFRÅGAN !

BESTÄLLNINGSEXEMPEL: 1931140020 - UFX 4.0X20 FZB POZI

BESTÄLLNINGSEXEMPEL: 19311400201 - UFX 4.0X20 FZB POZI *BULK*

SWEBOLT AB

TEL 08 - 555 975 00 FAX 08 - 583 581 82

ARTIKELLISTA
2013-2014
UNIVERSALSKRUV KULLRIG
UKT FZB STAR
BLANKFÖRZINKAD



S=SMÅPACK

B=BULK (GRÅTT FÄLT)

DIM	2.5	2.5	3	3	3.5	3.5	4	4	4.5	4.5	5	5	6	6
Skalld	4.6	4.6	6	6	7	7	8	8	9	9	10	10	12	12
Skallh			2.2	2.2	2.6	2.6	3	3	3.6	3.6	4	4	4.5	4.5
FÖRP.	S	B	S	B	S	B	S	B	S	B	S	B	S	B
STAR	T-5	T-5	T-10	T-10	T-10	T-10	T-20	T-20	T-20	T-20	T-25	T-25	T-30	T-30
Längd	C:A PRIS/100 ST													
10														
12														
15														
16							X		X		X			
20							X		X		X			
25							X		X		X			
30							X		X		X		X	
35							X		X		X		X	
40							X		X		X		X	
45							X		X		X		X	
50							X		X		X		X	
55														
60							X		X		X		X	
70											X		X	
80											X		X	
90											X		X	
100											X		X	

ÖVRIGA DIMENSIONER OCH LÄNGDER MOT FÖRFRÅGAN !

FÖRP.	2.5	B	3	B	3.5	B	4	B	4.5	B	5	B	6	B
200 ST	10-		10-		12-		12-		16-		16-		30-	

BESTÄLLNINGSEXEMPEL: 1935140020 - UKT 4.0X20 FZB STAR
 BESTÄLLNINGSEXEMPEL: 19351400201 - UKT 4.0X20 FZB STAR *BULK*

BITS UNDER FLIK 18 !

SWEBOLT AB

TEL 08 - 555 975 00 FAX 08 - 583 581 82

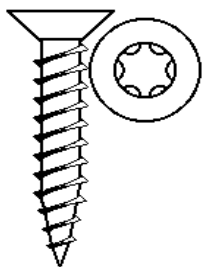

ARTIKELLISTA

2013-2014

UNIVERSALSKRUV FÖRSÄNKT

UFT FZB STAR

BLANKFÖRZINKAD



S=SMÅPACK

B=BULK (GRÅTT FÄLT)

DIM	2.5	2.5	3	3	3.5	3.5	4	4	4.5	4.5	5	5	6	6
Skallld	4.6	4.6	6	6	7	7	8	8	9	9	10	10	12	12
Skallh			1.9	1.9	2.1	2.1	2.5	2.5	2.7	2.7	3	3	3.6	3.6
FÖRP.	S	B	S	B	S	B	S	B	S	B	S	B	S	B
STAR	T-5	T-5	T-10	T-10	T-10	T-10	T-20	T-20	T-20	T-20	T-25	T-25	T-30	T-30
Längd	C:A PRIS/100 ST													
10														
12														
15														
16							X		X		X			
20							X		X		X			
25							X		X		X			
30							X		X		X		X	
35							X		X		X		X	
40							X		X		X		X	
45							X		X		X		X	
50							X		X		X		X	
55											X			
60							X		X		X		X	
70							X		X		X		X	
80									X		X		X	
90											X		X	
100											X		X	
110													X	
120											X		X	
130													X	
140													X	
150													X	
160													X	
180													X	
200													X	

ÖVRIGA DIMENSIONER OCH LÄNGDER MOT FÖRFRÅGAN !

FÖRP.	2.5	B	3	B	3.5	B	4	B	4.5	B	5	B	6	B
200 ST	10-		10-		12-		12-		12-		16-		30-	
100 ST											70-		70-	

BESTÄLLNINGSEXEMPEL: 1934150070 - UFT 5.0X70 FZB POZI

SWEBOLT AB

TEL 08 - 555 975 00 FAX 08 - 583 581 82

ARTIKELLISTA
2013-2014
FRANSK TRÄSKRUV 6-KANT
SYRAFAST A4
T6S A4 DIN 571

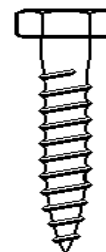

DIM	6	8	10	12	16	20
NV	10	13	17	19	24	30
Skallh	4	5.5	7	8	10	13
Längd	C:A PRIS/100 ST					
25	X	X				
30	X	X				
35	X	X				
40	X	X	X			
45	X	X	X			
50	X	X	X	X		
55	X	X	X			
60	X	X	X	X	X	
65	X	X	X			
70	X	X	X	X	X	
75	X	X	X	X		
80	X	X	X	X	X	
90	X	X	X	X	X	
100	X	X	X	X	X	
110	X	X	X	X	X	
120	X	X	X	X	X	
130	X	X	X	X	X	
140		X	X	X	X	
150		X	X	X	X	
160		X	X	X	X	
180		X	X	X	X	
200			X	X	X	
220						
240						
260						
280						
300						
360						
FÖRP.	6	8	10	12	16	20
100 ST	25-	25-	25-			
50 ST			80-	50-		
25 ST			160-	100-		

BESTÄLLNINGSEXEMPEL: 2902110100 - T6S 10X100 A4

SWEBOLT AB
TEL 08 - 555 975 00 FAX 08 - 583 581 82

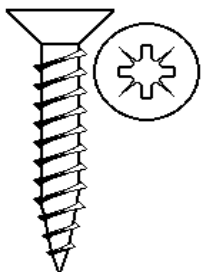

ARTIKELLISTA
2013-2014
UNIVERSALSKRUV FÖRSÄNKT
ROSTFRI A2

UFX A2

DIM	3	3.5	4	4.5	5	6
Skalld	6	7	8	9	10	12
Skallh	1.9	2.1	2.5	2.7	3	3.6
Längd	C:A PRIS/100 ST					
10						
12						
15						
16	X					
20			X		X	
25	X	X	X	X	X	
30	X			X	X	X
35	X	X	X	X	X	
40		X		X	X	
45					X	
50			X	X		X
55						
60			X	X	X	X
65						
70						X
80						X
90						
100					X	

ÖVRIGA DIMENSIONER OCH LÄNGDER MOT FRÖFRÅGAN !

FÖRP.	3	3.5	4	4.5	5	6
500 ST	16-	25-	20-	25-	20-	
200 ST		40-	40-	40-	40-	30-
100 ST					80-	80-

BESTÄLLNINGSEXEMPEL: 2931130016 - UFX 3.0X16 A2 POZI

SWEBOLT AB

TEL 08 - 555 975 00 FAX 08 - 583 581 82

ARTIKELLISTA
2013-2014
UNIVERSALSKRUV FÖRSÄNKT
SYRAFAST A4

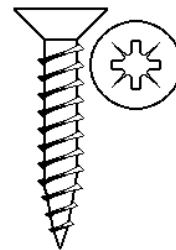

UFX A4

DIM	3	3.5	4	4.5	5	6
Skalld	6	7	8	9	10	12
Skallh	1.9	2.1	2.5	2.7	3	3.6
Längd	C:A PRIS/100 ST					
10			X			
12			X			
15						
16	X	X	X		X	
20	X	X	X	X	X	
25	X	X	X	X	X	X
30	X	X	X	X	X	X
35	X	X	X	X	X	X
40	X	X	X	X	X	X
45					X	X
50			X	X	X	X
55						
60			X	X	X	X
65						
70			X		X	X
80					X	X
90					X	X
100						X

ÖVRIGA DIMENSIONER OCH LÄNGDER MOT FÖRFRÅGAN !

FÖRP.	3	3.5	4	4.5	5	6
200 ST	12-	12-	12-	16-	20-	25-
100 ST						60-

BESTÄLLNINGSEXEMPEL: 2931230016 - UFX 3.0X16 A4 POZI

ARTIKELLISTA
2013-2014
UNIVERSALSKRUV KULLRIG
SYRAFAST A4

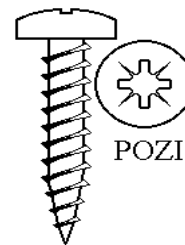

UKX A4

DIM	2.5	3	3.5	4	4.5	5	6
Skalld		6	7	8	9	10	12
Skallh		2.2	2.6	3	3.6	4	4.5
Längd	C:A PRIS/100 ST						
10							
12		X	X				
15							
16		X	X	X	X	X	
20		X	X	X	X	X	
25		X	X	X	X	X	X
30		X	X	X	X	X	X
35				X	X	X	
40			X	X	X	X	X
45							
50				X	X	X	X
55							
60				X		X	X
65							
70						X	X
80						X	X
90							X
100							X

ÖVRIGA DIMENSIONER OCH LÄNGDER MOT FÖRFRÅGAN !

FÖRP.	2.5	3	3.5	4	4.5	5	6
200 ST		12-	16-	16-	16-	20-	25-
100 ST							60-

BESTÄLLNINGSEXEMPEL: 2930230012 - UKX 3.0X12 A4 POZI

BITS UNDER FLIK 18 !

SWEBOLT AB
TEL 08 - 555 975 00 FAX 08 - 583 581 82

ARTIKELLISTA
2013-2014
UNIVERSALSKRUV KULLERFÖRSÄNKT
SYRAFAST A4

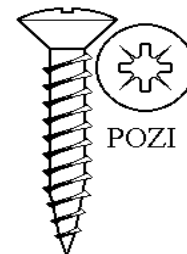

UKFX A4

DIM	2.4	3	3.5	4	4.5	5	6
Skallh		6	7	8	9	10	12
Skalld		1.9	2.1	2.5	2.7	3	3.6
Längd	C:A PRIS/100 ST						
12				X			
16							
20				X		X	
25				X		X	
30						X	
35							
40				X		X	
45							
50				X		X	
60							
70							
80							

ÖVRIGA DIMENSIONER OCH LÄNGDER MOT FÖRFRÅGAN !

FÖRP.	2.4	3	3.5	4	4.5	5	6
200 ST		12-		16-		20-	

BESTÄLLNINGSEXEMPEL: 2932140016 - UKFX 4.0X16 A4 POZI

SWEBOLT AB

TEL 08 - 555 975 00 FAX 08 - 583 581 82

ARTIKELLISTA
2013-2014
UNIVERSALSKRUV FÖRSÄNKT
SYRAFAST A4

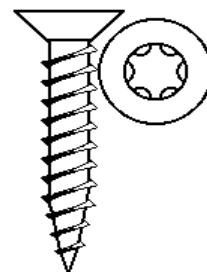

UFT A4 STAR

DIM	3	3.5	4	4.5	5	6
Skalld	6	7	8	9	10	12
Skallh	1.9	2.1	2.5	2.7	3	3.6
STAR	T-10	T-15	T-20	T-20	T-25	T-25
Längd	C:A PRIS/100 ST					
10						
12						
15						
16						
20			X			
25			X	X	X	
30			X	X	X	X
35			X	X	X	X
40			X	X	X	X
45			X	X	X	X
50			X	X	X	X
55						
60			X	X	X	X
65						
70			X	X	X	X
80					X	X
90					X	X
100					X	X
120						X
130						
140						X

ÖVRIGA DIMENSIONER OCH LÄNGDER MOT FÖRFRÅGAN !

FÖRP.	3	3.5	4	4.5	5	6
200 ST	12-	12-	12-	16-	20-	25-
100 ST			60-	60-	60-	50-

BESTÄLLNINGSEXEMPEL: 2934160100 - UFT 6.0x100 A4 STAR

ARTIKELLISTA
2013-2014
UNIVERSALSKRUV KULLRIG
SYRAFAST A4

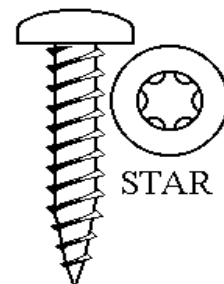

UKT A4 STAR

DIM	3	3.5	4	4.5	5	6
Skalld	6	7	8	9	10	12
Skallh	2.2	2.6	3	3.6	4	4.5
STAR	T-10	T-15	T-20	T-20	T-25	T-25
Längd	C:A PRIS/100 ST					
10						
12						
15						
16			X			
20			X	X		
25			X	X	X	
30			X	X	X	
35			X	X	X	X
40			X	X	X	X
45			X			
50			X	X	X	X
55						
60			X		X	X
65						
70					X	X
80					X	X
90						X
100						X

ÖVRIGA DIMENSIONER OCH LÄNGDER MOT FÖRFRÅGAN !

FÖRP.	3	3.5	4	4.5	5	6
200 ST	12-	16-	16-	16-	20-	25-
100 ST					60-	60-

BESTÄLLNINGSEXEMPEL: 2935150070 - UKT 5.0X70 A4 STAR

BITS UNDER FLIK 18 !

SWEBOLT AB
TEL 08 - 555 975 00 FAX 08 - 583 581 82

ARTIKELLISTA

2013-2014

TRALLSKRUV MED RILLOR SYRAFAST A4 STAR

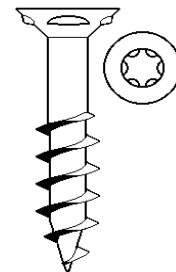

DIM	4.2	4.8
Skalldiameter	7.4	8.4
Skallhöjd	3	3.6
STAR	T15	T15

DIM	GL	C:A PRIS/100 ST			
		PAPPBOX		PLASTBOX	
		FÖRP	PRIS	FÖRP	PRIS
4.2x32	20mm	200	X	400	X
4.2x35	20	200	X	400	X
4.2x41	20	200	X	400	X
4.2x45	20	200	X	400	X
4.2x51	26	200	X	400	X
4.2x55	26	200	X	400	X
4.8x75	36	100	X	200	X
4.8x90	50	100	X		

BESTÄLLNINGSEXEMPEL: 2151364251 - TRALLSKRUV 4.2X51 A4 STAR

TRALLSKRUV med RILLOR, PLAN SKALLE SYRAFAST A4 STAR

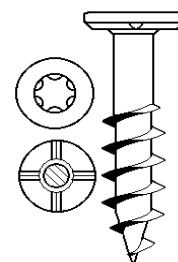

DIM	4.2
Skalldiameter	7.4
Skallhöjd	3
STAR	T15

DIM	GL	C:A PRIS/100 ST			
		PAPPBOX		PLASTBOX	
		FÖRP	PRIS	FÖRP	PRIS
4.2x35	20mm	200	X	400	X
4.2x40	20	200	X	400	X
4.2x45	20	200	X	400	X
4.2x50	26	200	X	400	X
4.2x55	26	200	X	400	X

BESTÄLLNINGSEXEMPEL: 2151384235 - PLAN TRALLSKRUV 4.2x35 A4 STAR

ÖVRIGA DIMENSIONER OCH LÄNGDER MOT FÖRFRÅGAN !



PAPPBOX



PLASTBOX

SWEBOLT AB

TEL 08 - 555 975 00 FAX 08 - 583 581 82

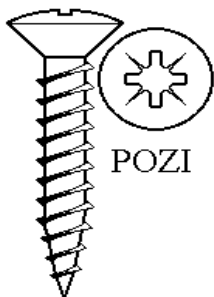

ARTIKELLISTA
2013-2014
POLERAD VVS-SKRUV
ROSTFRI A2

VVS A2

DIM	4	5	5.5	6
Skalld	8	9.9	11	11.9
Skallh	4.1	5.1	5.6	6.7
Längd	C:A PRIS/100 ST			
30	X	X	X	
35				
40	X	X	X	
45				
50		X	X	
55				
60			X	X
65				
70				
75 / 60			X	X
80				
90 / 70			X	
100 / 80			X	X









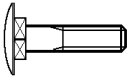
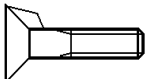
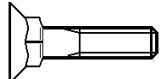
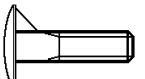
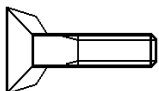

BESTÄLLNINGSEXEMPEL: 2932240030 - UKFX-P 4.0X30 A2 POZI POLERAD

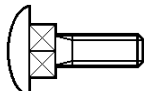
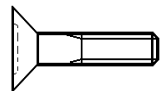
FÖRP.	4	4.5	5	6
100 ST	30-	30-	30-	60-

BITS UNDER FLIK 18 !

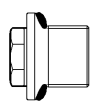
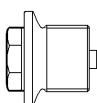
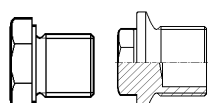
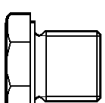
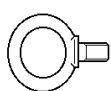

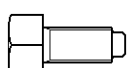
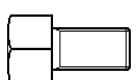
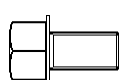
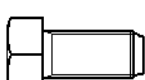
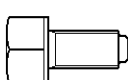
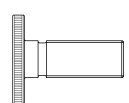
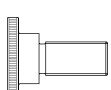
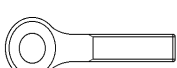

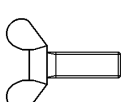
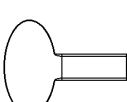
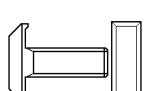
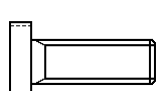
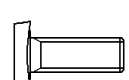
SWEBOLT AB

TEL 08 - 555 975 00 FAX 08 - 583 581 82

- 1 - 	- 2 - 	- 3 - 	- 4 - 
- 5 - 	- 6 - 	- 7 - 	- 8 - 
- 9 - 	- 10 - 	- 11 - 	- 12 - 
- 13 - 	- 14 - 	- 15 - 	- 16 - 
- 17 - 	- 18 - 	- 19 - 	- 20 - 
- 21 - 	- 22 - 	- 23 - 	- 24 - 
- 25 - 	- 26 - 	- 27 - 	- 28 - 
- 29 - 	- 30 - 	- 31 - 	- 32 - 

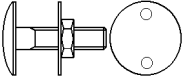
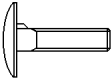
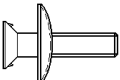
SWEBOLT AB

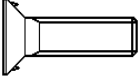
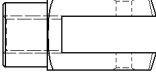
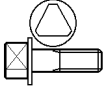
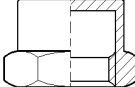
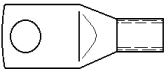
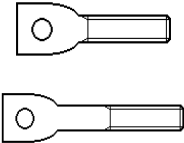
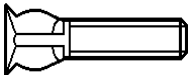
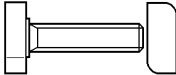
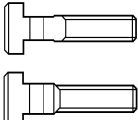
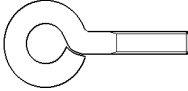
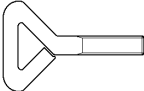
TEL. 08-584 909 60 FAX. 08-583 581 82

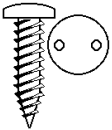
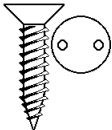
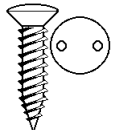
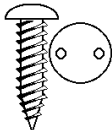
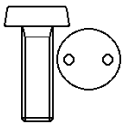
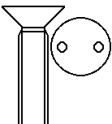
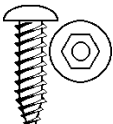
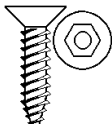
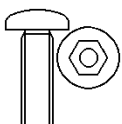
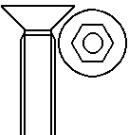
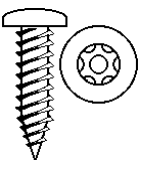
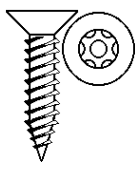
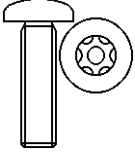
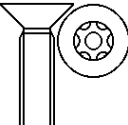
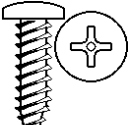
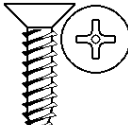
- 33 - 	- 34 - 	- 35 - 	- 36 - 
- 37 - 	- 38 - 	- 39 - 	- 40 - 
- 41 - 	- 42 - 	- 43 - 	- 44 - 
- 45 - 	- 46 - 	- 47 - 	- 48 - 
- 49 - 	- 50 - 	- 51 - 	- 52 - 
- 53 - 	- 54 - 	- 55 - 	- 56 - 
- 57 - 	- 58 - 	- 59 - 	- 60 - 
- 61 - 	- 62 - 	- 63 - 	- 64 - 

SWEBOLT AB

TEL. 08-584 909 60 FAX. 08-583 581 82

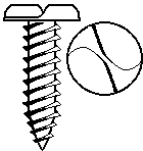
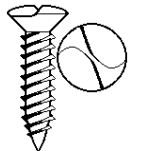
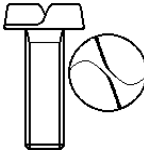
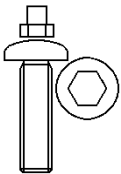
<p style="text-align: center;">- 65 -</p> 	<p style="text-align: center;">- 66 -</p> 	<p style="text-align: center;">- 67 -</p> 	<p style="text-align: center;">- 68 -</p> 
<p style="text-align: center;">- 69 -</p>	<p style="text-align: center;">- 70 -</p>	<p style="text-align: center;">- 71 -</p>	<p style="text-align: center;">- 72 -</p>
<p style="text-align: center;">- 73 -</p>	<p style="text-align: center;">- 74 -</p>	<p style="text-align: center;">- 75 -</p>	<p style="text-align: center;">- 76 -</p>
<p style="text-align: center;">- 77 -</p>	<p style="text-align: center;">- 78 -</p>	<p style="text-align: center;">- 79 -</p>	<p style="text-align: center;">- 80 -</p>
<p style="text-align: center;">- 81 -</p>	<p style="text-align: center;">- 82 -</p>	<p style="text-align: center;">- 83 -</p>	<p style="text-align: center;">- 84 -</p>
<p style="text-align: center;">- 85 -</p>	<p style="text-align: center;">- 86 -</p>	<p style="text-align: center;">- 87 -</p>	<p style="text-align: center;">- 88 -</p>
<p style="text-align: center;">- 89 -</p>	<p style="text-align: center;">- 90 -</p>	<p style="text-align: center;">- 91 -</p>	<p style="text-align: center;">- 92 -</p>
<p style="text-align: center;">- 93 -</p>	<p style="text-align: center;">- 94 -</p>	<p style="text-align: center;">- 95 -</p>	<p style="text-align: center;">- 96 -</p>

SWEBOLT AB

TEL. 08-584 909 60 FAX. 08-583 581 82

PRODUKTER I STÅL

1	110001	MVBF, VAGNSBULT	603	8677	4.6	OBEH	10:1
1	110002	MVBF, VAGNSBULT	603	8677	4.6	FZB	10:1
1	710003	MVBF, VAGNSBULT	603	8677	4.6	DEPO	10:7
1	110004	MVBF, VAGNSBULT	603	8677	8.8	OBEH	10:8
1	110005	MVBF, VAGNSBULT	603	8677	8.8	FZB	10:8
1	110006	MVBF, VAGNSBULT	603	8677	8.8	FZV	10:8
1	110008	UVBF, VAGNSBULT UNC	603		4.6	OBEH	10:27
1	110009	UVBF, VAGNSBULT UNC	603		4.6	FZB	10:27
2	110010	MVBFFK, FÖRS. m. KNASTER	604		4.6	OBEH	10:9
2	110011	MVBFFK, FÖRS. m. KNASTER	604		4.6	FZB	10:9
3	110015	MVBFF, FÖRSÄNKT VAGNSBULT	605		4.6	OBEH	10:10
3	110016	MVBFF, FÖRSÄNKT VAGNSBULT	605		4.6	FZB	10:10
3	110017	MVBFF, FÖRSÄNKT VAGNSBULT	608		4.6	OBEH	10:11
3	110018	MVBFF, FÖRSÄNKT VAGNSBULT	608		8.8	OBEH	10:11
4	110020	MVBFK, VAGNSB. m. KNASTER	607		4.6	OBEH	10:12
4	110021	MVBFK, VAGNSB. m. KNASTER	607		4.6	FZB	10:12
5	110025	KLÄMSKRUV				OBEH	10:13
5	110026	KLÄMSKRUV				FZB	10:13
5	110035	FÖRSÄNKT m. TVÅ KNASTER	25195			OBEH	10:13
5	110036	FÖRSÄNKT m. TVÅ KNASTER	25195			FZB	10:13
6	110040	VÄGRÄCKESSKRUV			4.6	FZV	10:14
7	110045	VHSS, VÄGHYVELSKRUV			8.8	OBEH	10:14
8	110046	MFSS, FÖRSÄNKT, MEJSELSPÅR	7969		4.6	OBEH	10:14
8	110047	MFSS, FÖRSÄNKT, MEJSELSPÅR	7969		4.6	FZB	10:14
9	110050	RP 906, KONISK, INV. 6-KANT	906	M+R	5.8	OBEH	10:2
9	110051	RP 906, KONISK, INV. 6-KANT	906	M+R	5.8	FOS	10:2
9	110052	RP 906, KONISK, INV. 6-KANT	906	M+R	5.8	FZB	10:2
10	110055	RP 908, INV. 6-KANT m. FLÄNS	908	M+R	5.8	OBEH	10:2
10	110056	RP 908, INV. 6-KANT m. FLÄNS	908	M+R	5.8	FOS	10:2
10	110057	RP 908, INV. 6-KANT m. FLÄNS	908	M+R	5.8	FZB	10:2
11	110060	RP 908T, FLÄNS OCH TÄTNING	908	M+R	5.8	OBEH	10:15
12	110065	RP 910, 6-KANT	910	M+R	5.8	OBEH	10:2
12	110066	RP 910, 6-KANT	910	M+R	5.8	FOS	10:2
12	110067	RP 910, 6-KANT	910	M+R	5.8	FZB	10:2
13	110070	RP 910T, 6-KANT m. TÄTNING	910	M+R	5.8	OBEH	10:15
14	110075	RP 910M, 6-KANT, MAGNETISK	910	M+R	5.8	OBEH	10:15
15	110080	RP, 6-KANT, METRISK GÄNGA	7604A+C		5.8	OBEH	10:17
15	110081	RP, 6-KANT, METRISK GÄNGA	7604A		5.8	FZB	10:17
15	110083	RP, 6-KANT, METRISK GÄNGA	7604C		5.8	FZB	10:17
16	110085	RP, 6-KANT, RÖRGÄNGA	7604C		5.8	FZB	10:17

SWEBOLT AB

TEL. 08-584 909 60 FAX. 08-583 581 82

BILD	ART.GR.	BENÄMNING	DIN	ISO	KVAL	YTBEH	SIDA
17	110100	LT, LYFTÖGLA, TAPP	580	3266	C15	OBEH	10:4
17	110101	LT, LYFTÖGLA, TAPP	580	3266	C15	FZB	10:4
17	110102	LT, LYFTÖGLA, TAPP	580	3266	C15	FZV	10:4
17	110105	LT, LYFTÖGLA, TAPP, UNC	580	3266	C15	OBEH	10:26
17	110106	LT, LYFTÖGLA, TAPP, UNC	580	3266	C15	FZB	10:26
17	110107	LT, LYFTÖGLA, TAPP, UNC	580	3266	C15	FZV	10:26
18	110110	LH, LYFTÖGLA, HÅL	582		C15	OBEH	10:4
18	110111	LH, LYFTÖGLA, HÅL	582		C15	FZB	10:4
18	110112	LH, LYFTÖGLA, HÅL	582		C15	FZV	10:4
18	110115	LH, LYFTÖGLA, HÅL, UNC	582		C15	OBEH	10:26
18	110116	LH, LYFTÖGLA, HÅL, UNC	582		C15	FZB	10:26
18	110117	LH, LYFTÖGLA, HÅL, UNC	582		C15	FZV	10:26
19	110120	T6SS, STÄLLSKR., 6-KANT, TAPP	561B		8.8	OBEH	10:20
20	110130	USK4SS, STÄLLSKRUV, 4-KANT				OBEH	10:20
21	110140	MSK4F, 4-KANT m. FLÄNS	478		8.8	OBEH	10:21
21	110142	MSK4F, 4-KANT m. FLÄNS	478		10.9	OBEH	10:21
22	110150	T4SS, STÄLLSKRUV	479		8.8	OBEH	10:21
22	110152	T4SS, STÄLLSKRUV	479		10.9	OBEH	10:21
23	110160	4-KANT m. TAPP OCH FLÄNS	480		8.8	OBEH	10:21
23	110165	4-KANT m. TAPP OCH FLÄNS	480		10.9	OBEH	10:21
24	110170	LETTERSKRUV	653		5.8	OBEH	10:6
24	110171	LETTERSKRUV	653		5.8	FZB	10:6
25	110180	LETTERSKRUV m. ANSATS	464		5.8	OBEH	10:6
25	110181	LETTERSKRUV m. ANSATS	464		5.8	FZB	10:6
26	110200	LS, LÄNKSKRUV	444 A,B,C		4.6	OBEH	10:22
26	110201	LS, LÄNKSKRUV	444 A,B,C		4.6	FZB	10:22
26	110203	LS, LÄNKSKRUV	444 A,B,C		8.8	OBEH	10:23
26	110204	LS, LÄNKSKRUV	444 A,B,C		8.8	FZB	10:23
26	110206	LS, LÄNKSKRUV	SMS			OBEH	10:24
26	110207	LS, LÄNKSKRUV	SMS			FZB	10:24
27	110210	HS, HAMMARSKRUV	186		4.6	OBEH	10:25
27	110211	HS, HAMMARSKRUV	186		4.6	FZB	10:25
28	110220	VS, VINGSKRUV	316			OBEH	10:5
28	110221	VS, VINGSKRUV	316			FZB	10:5
29	110230	BS, BLADSKRUV				OBEH	10:16
29	110230	BS, BLADSKRUV				FZB	10:16
30	110300	UHS, UPPHÄNGNINGSSKRUV			4.6	OBEH	10:30
30	110301	UHS, UPPHÄNGNINGSSKRUV			4.6	FZB	10:30

SWEBOLT AB

TEL. 08-584 909 60 FAX. 08-583 581 82

BILD	ART.GR.	BENÄMNING	DIN	ISO	KVAL	YTBEH	SIDA
31	110310	SS, SKENSKRUV				OBEH	10:30
31	110311	SS, SKENSKRUV				FZB	10:30
32	110320	SUHS, UPPHÄNGNINGSSKRUV, SMAL				OBEH	10:31
32	110321	SUHS, UPPHÄNGNINGSSKRUV, SMAL				FZB	10:31
33	110400	ELEVATORSK., INKL. MUTTER o. BRICKA				FZB	10:32
34	110405	ELEVATORSK., MED NIBB				FZB	10:32
35	110410	ELEVATORSK., LÅSTAPP MED MUTTER o. BRICKA				FZB	10:33
36	110415	ELEVATORSK., MUTTER+LÅSTAPP				FZB	10:33
37	110420	FÖRSÄNKT ELEVATORSK., MUTTER+LÅSTAPP				FZB	10:33
38	110430	GAFFELLÄNK	71752			OBEH	10:34
39	110440	M3S, TREKANTSSKRUV				OBEH	10:34
40	110460	RF, FÖRSLUTNING	7605			OBEH	10:35
40	110461	RF, FÖRSLUTNING	7605			FZB	10:35
41	110470	BLADHYLSA				OBEH	10:5
41	110471	BLADHYLSA				FZB	10:5
42	110425	PS, PENDELSKRUV				FZB	10:5
43	110028	DS, DRAGSKRUV				FZB	10:13
44	110511	SKENSKRUV				FZB	10:31
45	110600	TB, T-SPÅRSBULT	787			FZB	10:36
46	110610	SÖ, SKRUVÖGLA				OBEH	10:6
46	110611	SÖ, SKRUVÖGLA				FZB	10:6
46	110612	SÖS, FÖRANKRINGSÖGLA SVETSAD				OBEH	
46	110613	SÖS, FÖRANKRINGSÖGLA SVETSAD				FZB	
47	110615	SÖT, SKRUVÖGLA, TREKANT				OBEH	10:37
47	110616	SÖT, SKRUVÖGLA, TREKANT				FZB	10:37
48	110620	VKM, VINKELKROK				OBEH	10:37
48	110621	VKM, VINKELKROK				FZB	10:37

ROSTFRITT / SYRAFAST

1	210001	MVBF, VAGNSBULT	603	8677	A2		10:41
1	210002	MVBF, VAGNSBULT	603	8677	A4		10:41
9	210050	RP 906, KONISK, INV. 6-KANT	906	M+R	A2		10:42
9	210051	RP 906, KONSIK, INV. 6-KANT	906	M+R	A4		10:42

SWEBOLT AB

TEL. 08-584 909 60 FAX. 08-583 581 82

BILD	ART.GR.	BENÄMNING	DIN	ISO	KVAL	YTBEH	SIDA
10	210055	RP 908, INV. 6-KANT m. FLÄNS	908	M+R	A2		10:42
10	210056	RP 908, INV. 6-KANT m. FLÄNS	908	M+R	A4		10:42
12	210065	RP 910, 6-KANT	910	M+R	A2		10:42
12	210066	RP 910, 6-KANT	910	M+R	A4		10:42
17	210100	LT, LYFTÖGLA, TAPP	580		A2		10:43
17	210101	LT, LYFTÖGLA, TAPP	580		A4		10:43
18	210110	LH, LYFTÖGLA, HÅL	582		A2		10:43
18	210111	LH, LYFTÖGLA, HÅL	582		A4		10:43
26	210200	LS, LÄNKSKRUV	444 B		A2		10:45
26	210201	LS, LÄNKSKRUV	444 B		A4		10:45
27	210210	HS, HAMMARSKRUV	186		A2		10:45
27	210211	HS, HAMMARSKRUV	186		A4		10:45
28	210220	VS, VINGSKRUV, AM-TYP	316		A2		10:44
28	210221	VS, VINGSKRUV, AM-TYP	316		A4		10:44
46	210610	SÖ, SKRUVÖGLA			A2		10:46
46	210611	SÖ, SKRUVÖGLA			A4		10:46

MÄSSING

1	310001	MVBF, VAGSBULT	603	8677			10:60
9	310050	RP-906, KONISK, INV. 6-KANT	906				10:61
10	310055	RP-908, INV. 6-KANT m. FLÄNS	908				10:61
12	310065	RP-910, 6-KANT	910				10:61
12	311066	RP-910, 6-KANT	910			FÖRNICKLAD	10:61
15	310080	RP, 6-KANT, METRISK GÄNGA	7604A				10:62
24	310170	LETTERSKRUV	653				10:62
28	310220	VS, VINGSKRUV	316				10:62
28	310221	VS, VINGSKRUV	316			FÖRNICKLAD	10:62

POLYAMID

16	410088	FS, FÖRSLUTNINGSSKRUV					10:70
28	410220	VS, VINGSKRUV	316				10:70

SWEBOLT AB

TEL. 08-584 909 60 FAX. 08-583 581 82



ARTIKELLISTA
2013-2014
VAGNSBULT
BLANKFÖRZINKAD
MVBF 4.6 FZB DIN 603

GÄNGA	M5	M6	M8	M10	M12	M16	M20
Skalldiam	13.6	16	20	24	30	38	46
Skallhöjd	3.3	3.5	4.5	5	6.5	8.5	10.5
4-kant	5.5	6	8	10	12	16	20
4-höjd	4	4	5	6	8	12	15
Längd	C:A PRIS/100 ST						
12		X					
16	X	X	X				
20	X	X	X	X			
25	X	X	X	X	X		
30	X	X	X	X	X		
35	X	X	X	X	X		
40	X	X	X	X	X	X	
45	X	X	X	X	X	X	
50	X	X	X	X	X	X	
55	X	X	X	X		X	
60	X	X	X	X	X	X	
65	X	X	X	X		X	
70	X	X	X	X	X	X	
75		X	X	X	X	X	
80	X	X	X	X	X	X	X
90	X	X	X	X	X	X	X
100		X	X	X	X	X	X
110		X	X	X	X	X	
120		X	X	X	X	X	X
130		X	X	X	X	X	
140		X	X	X	X	X	X
150		X	X	X	X	X	X
160			X	X	X	X	X
180			X	X	X	X	X
200			X	X	X	X	X
220				X	X	X	X
240				X	X	X	X
260				X	X	X	X
280				X	X	X	X
300				X	X	X	X

ÖVRIGA DIMENSIONER OCH LÄNGDER MOT FÖRFRÅGAN !

FÖRP.	M5	M6	M8	M10	M12	M16	M20
200 ST		12-	16-				
100 ST		60-	30-	30-			
50 ST			100-	65-	30-		
25 ST			180-	120-	80-	50-	100-
10 ST					260-		

BESTÄLLNINGSEXEMPEL: 11000210050 - MVBF M10X50 4.6 FZB

SWEBOLT AB

TEL 08 - 555 975 00 FAX 08 - 583 581 82

ARTIKELLISTA

2013-2014

RÖRPROPPAR DIN 906 - DIN 908 - DIN 910 OBEH - FOS - FZB

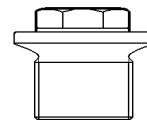

C:A PRIS/100 ST									
DIM	DIN 906			DIN 908			DIN 910		
	OBEH	FOS	FZB	OBEH	FOS	FZB	OBEH	FOS	FZB
M6x1	X								
M8x1		X			X				
M10x1		X		X	X				
M12x1.5		X			X	X			
M14x1.5		X		X	X		X		
M16x1.5		X		X	X				
M18x1.5		X		X	X		X		
M20x1.5		X					X		
M22x1.5				X	X		X		X
M24x1.5				X					
M26x1.5									
M27x2				X					
M30x1.5		X			X				
M30x2									
M33x2									
M36x1.5									
M36x2									
M38x1.5									
M42x1.5				X					
M42x2									
M45x1.5									
M45x2									
M48x1.5									
M48x2									

BESTÄLLNINGSEXEMPEL:
 110051100 - RP 906 M10X1 5.8 FOSF
 110050100 - RP 906 M10X1 5.8 OBEH
 110056100 - RP 908 M10X1 5.8 FOSF
 110055100 - RP 908 M10X1 5.8 OBEH

C:A PRIS/100 ST									
DIM	DIN 906			DIN 908			DIN 910		
	OBEH	FOS	FZB	OBEH	FOS	FZB	OBEH	FOS	FZB
R 1/8		X		X	X	X			
R 1/4		X			X	X			
R 3/8		X		X		X	X		
R 1/2		X			X		X		X
R 5/8									
R 3/4		X			X		X		X
R 7/8									
R 1		X							
R 1 1/8									
R 1 1/4									X
R 1 1/2									
R 1 3/4									
R 2									

ÖVRIGA DIMENSIONER MOT FÖRFRÅGAN !

FÖRP	OBEH	FOS	FZB	OBEH	FOS	FZB	OBEH	FOS	FZB
100 ST	M6-	M6-	M6-	M6-	M6-	M6-	M6-	M6-	M6-
50 ST	M12-	M12-	M12-	M12-	M12-	M12-	M12-	M12-	M12-
25 ST	M18-	M18-	M18-	M18-	M18-	M18-	M18-	M18-	M18-
10 ST	M27-	M27-	M27-	M27-	M27-	M27-	M27-	M27-	M27-

SWEBOLT AB

TEL 08 - 555 975 00 FAX 08 - 583 581 82

ARTIKELLISTA

2013-2014

LYFTÖGLA TAPP - LT - DIN 580

LYFTÖGLA HÅL - LH - DIN 582

OBEH - FZB - FZV

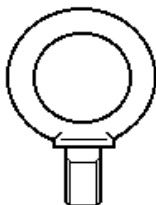

C:A PRIS/100 ST						
DIM	LT DIN 580			LH DIN 582		
	OBEH	FZB	FZV	OBEH	FZB	FZV
M6	X		X	X	X	X
M8	X		X	X	X	X
M10	X		X	X	X	X
M12	X		X	X	X	X
M16	X		X	X		X
M20	X		X	X		X
M24	X		X	X		X
M27	X			X		
M30	X		X	X	X	X
M36	X		X	X		X
M42	X			X		
M48	X					
M64						
M72						

FÖRP.	OBEH	FZB	FZV	OBEH	FZB	FZV
50 ST	M6-	M6-	M6-	M6-	M6-	M6-
25 ST	M12-	M12-	M12-	M12-	M12-	M12-
1 ST	M20-	M20-	M20-	M20-	M20-	M20-

BESTÄLLNINGSEXEMPEL: 110100100 - LT M10 C15 OBEH

BESTÄLLNINGSEXEMPEL: 110101100 - LT M10 C15 FZB

BESTÄLLNINGSEXEMPEL: 110102100 - LT M10 C15 FZV

BESTÄLLNINGSEXEMPEL: 110110100 - LH M10 C15 OBEH

BESTÄLLNINGSEXEMPEL: 110111100 - LH M10 C15 FZB

BESTÄLLNINGSEXEMPEL: 110112100 - LH M10 C15 FZV

ÖVRIGA DIMENSIONER OCH TAPPLÄNGDER MOT FÖRFRÅGAN !

SWEBOLT AB

TEL 08 - 555 975 00 FAX 08 - 583 581 82

ARTIKELLISTA

2013-2014

BLADHYLSA - VINGSKRUV - PENDELSKRUV

BLADHYLSA

FZB



C:A PRIS/100 ST				
DIM	Bladbredd	Hål	Tot.längd	FZB
M6	16.74	6.2	43.7	X
M8	18.4	8.2	45.42	X
M10	21.49	10.2	51.22	X
M12	25.32	12.3	60.23	X

FÖRP	
100 ST	M6-
50 ST	M10-

BESTÄLLNINGSEXEMPEL: 110471080 - BLADHYLSA M8 FZB

PENDELSKRUV PS

FZB



C:A PRIS/100 ST							
DIM	FZB	DIM	FZB	DIM	FZB	DIM	FZB
M8x50	X	M8x180	X	M8x320	X	M10x80	X
M8x60	X	M8x200	X	M8x340	X	M10x100	X
M8x80	X	M8x220	X	M8x360	X	M10x120	X
M8x100	X	M8x240	X	M8x380	X	M10x140	X
M8x120	X	M8x260	X	M8x400	X	M10x160	X
M8x140	X	M8x280	X	M10x50	X	M10x180	X
M8x160	X	M8x300	X	M10x60	X	M10x200	X

BESTÄLLNINGSEXEMPEL: 11042508100 - PS M8X100 FZB

FÖRP	
100 ST	tom. 300mm
50 ST	över 300mm

VINGSKRUV VS DIN 316

FZB

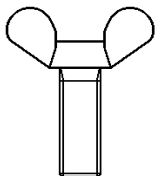

DIM	M3	M4	M5	M6	M8	M10	M12
NV	16	20	26	33	39	51	65
Höjd	8	10.5	13	17	20	25	33
Längd	C:A PRIS/100 ST						
8		X					
10		X	X	X			
12		X	X	X	X		
16	X		X	X	X	X	
20			X	X	X	X	X
25			X	X	X	X	X
30				X	X	X	X
35						X	X
40				X	X	X	X
50					X	X	X
60					X	X	
70					X		
80							

BESTÄLLNINGSEXEMPEL: 11022110016 - VS M10X16 FZB

FÖRP	M3	M4	M5	M6	M8	M10	M12
200 ST	8-	8-	8-	8-			
100 ST				16-	10-		
50 ST					40-	16-	
25 ST							20-

SWEBOLT AB

TEL 08 - 555 975 00 FAX 08 - 583 581 82

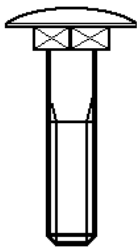

ARTIKELLISTA
2013-2014
VAGNSBULT
DELTA
MVBF 4.6 DEPO DIN 603

GÄNGA	M6	M8	M10	M12	M16	M20
Skalldiam	16	20	24	30	38	46
Skallhöjd	3.5	4.5	5	6.5	8.5	10.5
4-kant	6	8	10	12	16	20
4-höjd	4	5	6	8	12	15
Längd	C:A PRIS/100 ST					
12						
16		X				
20		X				
25		X	X			
30		X	X			
35		X	X			
40		X	X	X		
45		X	X	X		
50		X	X	X		
55		X	X	X		
60		X	X	X		
65		X	X			
70		X	X	X		
75						
80		X	X	X		
90		X	X	X		
100		X	X	X		
110		X	X	X		
120		X	X	X		
130		X	X	X		
140		X	X	X		
150		X	X	X		
160		X	X	X		
180		X	X	X		
200		X	X	X		
220			X	X		
240			X	X		
260			X	X		
280			X	X		
300			X	X		

ÖVRIGA DIMENSIONER OCH LÄNGDER MOT FÖRFRÅGAN !

FÖRP.	M6	M8	M10	M12	M16	M20
200 ST	12-	16-				
100 ST	60-	30-	30-			
50 ST		100-	65-	30-		
25 ST		180-	120-	80-	50-	100-
10 ST				260-		

BESTÄLLNINGSEXEMPEL: 71000210050 - MVBF M10X50 4.6 DEPO

SWEBOLT AB

TEL 08 - 555 975 00 FAX 08 - 583 581 82

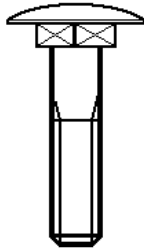

ARTIKELLIISTA

2013-2014 VAGNSBULT ROSTFRI A2 MVBF A2 DIN 603

DIM	M6	M8	M10	M12	M16
Skalldiam	16	20	24	30	39
Skallhöjd	3.5	4.5	5	6.5	9
4-kant	6	8	10	12	16.7
Höjd	4	5	6	8	12.9
Längd	C:A PRIS/100 ST				
16	X	X			
20	X	X			
25	X	X			
30	X	X		X	
35	X	X	X		
40	X	X	X	X	
45	X	X			
50	X	X		X	X
55	X	X			
60	X	X		X	
65	X				
70	X	X			
80	X	X			
90					
130	X				

BESTÄLLNINGSEXEMPEL: 21000108050 - MVBF M8X50 A2

SYRAFAST A4 MVBF A4 DIN 603

DIM	M6	M8	M10	M12	M16
Längd	C:A PRIS/100 ST				
16	X				
20	X	X			
25	X	X	X	X	
30	X	X	X	X	
35	X	X	X		
40	X	X	X	X	
45	X	X			
50	X	X	X	X	X
60	X	X	X	X	
65		X			
70	X	X	X	X	
80		X	X	X	
90		X	X		
100		X	X	X	
110		X			
120		X	X		

BESTÄLLNINGSEXEMPEL: 21000208050 - MVBF M8X50 A4

ÖVRIGA DIMENSIONER OCH LÄNGDER MOT FÖRFRÅGAN !

FÖRP.	M6	M8	M10	M12	M16
200 ST	16-				
100 ST	30-	20-	25-	25-	
50 ST				30-	50-

SWEBOLT AB

TEL 08 - 555 975 00 FAX 08 - 583 581 82

ARTIKELLISTA

2013-2014

LYFTÖGLA TAPP - LT - DIN 580

LYFTÖGLA HÅL - LH - DIN 582

ROSTFRI A2, SYRAFAST A4

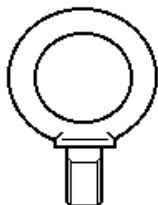

C:A PRIS/100ST				
DIM	LT DIN 580		LH DIN 582	
	A2	A4	A2	A4
M6	X	X	X	X
M8	X	X	X	X
M10	X	X	X	X
M12	X	X	X	X
M16	X	X	X	X
M20	X	X	X	X

BESTÄLLNINGSEXEMPEL: 210101120 - LT M12 A4

BESTÄLLNINGSEXEMPEL: 210111160 - LH M16 A4

ÖVRIGA DIMENSIONER OCH TAPPLÄNGDER MOT FÖRFRÅGAN !

SWEBOLT AB

TEL 08 - 555 975 00 FAX 08 - 583 581 82

ARTIKELLISTA

2013-2014

VS - VINGSKRUV DIN 316 A2 AM-FORM

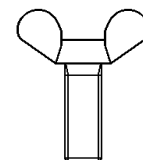

DIM	M3	M4	M5	M6	M8	M10	M12
Bredd	17.6	17.6	22.5	27.8	30.3	36.2	49.4
Höjd	8.6	8.6	11	13.6	14.8	17.7	24.1
Höjd inner	2.9	2.9	4.1	5.1	5.6	6.8	9
Längd	C:A PRIS/100						
10	X	X	X	X	X		
12	X	X	X	X	X		
16	X	X	X	X	X	X	
20	X	X	X	X	X	X	X
25	X	X	X	X	X	X	X
30	X	X	X	X	X	X	X
35		X	X	X	X	X	X
40		X	X	X	X	X	X
45			X	X	X	X	X
50			X	X	X	X	X
55					X	X	X
60					X	X	X
FÖRP.	M3	M4	M5	M6	M8	M10	M12
100 ST	10-	10-	10-				
50 ST				10-	10-	16-	
25 ST							25-
1 ST							

BESTÄLLNINGSEXEMPEL: 21022006020 - VS M6x20 A2

VS - VINGSKRUV DIN 316 A4 AM-FORM

DIM	M3	M4	M5	M6	M8	M10	M12
Längd	C:A PRIS/100						
10	X	X	X	X	X		
12	X	X	X	X	X		
16	X	X	X	X	X	X	
20	X	X	X	X	X	X	X
25	X	X	X	X	X	X	X
30	X	X	X	X	X	X	X
35		X	X	X	X	X	X
40		X	X	X	X	X	X
45			X	X	X	X	X
50			X	X	X	X	X
55					X	X	X
60					X	X	X
FÖRP.	M3	M4	M5	M6	M8	M10	M12
100 ST	10-	10-	10-				
50 ST				10-	10-	16-	
25 ST							25-
1 ST							

BESTÄLLNINGSEXEMPEL: 21022106016 - VS M6x16 A4

SWEBOLT AB

TEL 08 - 555 975 00 FAX 08 - 583 581 82

10:44

ARTIKELLISTA

2013-2014

SVETSBULT ISO 13918 STÅL/KOPPARBEL - ALUMINIUM ROSTFRI A2 - MÄSSING

GÅNGA	M3				M4				M5			
D+/-0.1	4.5				5.5				6.5			
d1+/-0.08	0.6				0.65				0.75			
L1 +/-0.05	0.55				0.55				0.8			
h	0.7-1.4				0.7-1.4				0.7-1.4			
vinkel	3				3				3			
C:A PRIS / 100 ST												
DIM	STÅL	A2	AlMg3	MÄSS	STÅL	A2	AlMg3	MÄSS	STÅL	A2	AlMg3	MÄSS
6	X	X	X		X	X	X					
8	X	X	X		X	X	X		X	X		
10	X	X	X		X	X	X		X	X	X	
12	X	X	X		X	X	X		X	X	X	
15	X	X	X		X	X	X		X	X	X	
20	X	X	X		X	X	X		X	X	X	
25	X	X	X		X	X	X		X	X	X	
30	X	X	X		X	X	X		X	X		
35					X	X						
40					X	X						
FÖRP.	STÅL	A2	AlMg3	MÄSS	STÅL	A2	AlMg3	MÄSS	STÅL	A2	AlMg3	MÄSS
500 ST	6-	6-	6-		6-	6-	6-		6-	6-	6-	

GÅNGA	M6				M8			
D+/-0.1	7.5				9,0			
d1+/-0.08	0.75				0.82			
L1 +/-0.05	0.8				1.9			
h	0.7-1.4				0.7-1.4			
vinkel	3				3			
C:A PRIS / 100 ST								
DIM	STÅL	A2	AlMg3	MÄSS	STÅL	A2	AlMg3	MÄSS
6								
8	X	X	X					
10	X	X	X		X	X		
12	X	X	X		X	X		
15	X	X	X		X	X		
20	X	X	X		X	X		
25	X	X	X		X	X		
30	X	X	X		X	X		
35	X	X			X	X		
40	X	X			X	X		
FÖRP.	STÅL	A2	AlMg3	MÄSS	STÅL	A2	AlMg3	MÄSS
500 ST	8-	8-	8-		10-	10-		
200 ST		30-				20-		

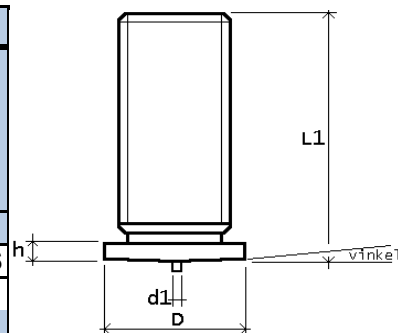













ÖVRIGA DIMENSIONER OCH LÄNGDER MOT FÖRFRÅGAN !

BESTÄLLNINGSEXEMPEL: 21080006015 - SVETSBULT M6X15 A2

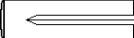
SWEBOLT AB

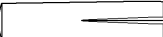
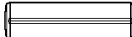
TEL 08 - 55 975 00 FAX 08 - 583 581 82

10:80

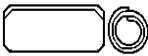
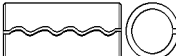
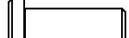
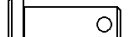
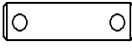
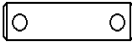
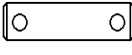
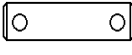
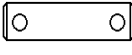
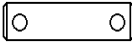
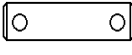
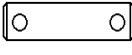
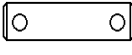
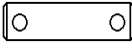
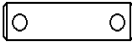
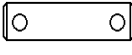
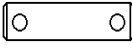
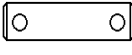
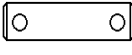
- 1 - 	- 2 - 	- 3 - 	- 4 - 
- 5 - 	- 6 - 	- 7 - 	- 8 - 
- 9 - 	- 10 - 	- 11 - 	- 12 - 
- 13 - 	- 14 - 	- 15 - 	- 16 - 
- 17 - 	- 18 - 	- 19 - 	- 20 - 
- 21 - 	- 22 - 	- 23 - 	- 24 - 
- 25 - 	- 26 - 	- 27 - 	- 28 - 
- 29 - 	- 30 - 	- 31 - 	- 32 - 

SWEBOLT AB

TEL. 08-584 909 60 FAX. 08-583 581 82

PRODUKTER I STÅL

1	111000	CP, CYL. PINNE	h8	7	2338	STÅL	11:1
1	111001	CP, CYL. PINNE	m6	7	2338	STÅL	11:1
1	111002	CP, CYL. PINNE	h6	7	2338	STÅL	11:3
2	111003	CPK, HÄRDAD CYL. PINNE	m6	6325	8734	STÅL	11:2
2	111004	CPK, HÄRDAD CYL. PINNE	h6	6325	8734	STÅL	11:2
3	111010	IGCP, INV. GÄNG PINNE	m6	7979	8735		11:6
4	111020	KP, KONISK PINNE		1	2339	STÅL	11:4
4	111021	KP, KONISK PINNE		1	2339	STÅL HÄRDAD	11:5
5	111030	IGKP, KONISK, INV. GÄNGA	h10	7978	8736		11:14
6	111040	GKP, GÄNG KONISK PINNE		258			11:7
6	111050	UGKP, GÄNG KONISK PINNE		UNC			11:14
6	111055	GKP, GÄNG KONISK PINNE		7977	8737		11:7
7	111060	RPC, RÄFFELPINNE		1470	8739		11:8
8	111070	RPA, RÄFFELPINNE		1471	8744		11:8
9	111080	RPB, RÄFFELPINNE		1472	8745		11:8
10	111090	RP, RÄFFELPINNE		1473	8740		11:9
11	111100	RPE, RÄFFELPINNE		1474	8741		11:9
12	111110	RPD, RÄFFELPINNE		1475	8742		11:9
13	111120	FRP, FJÄDRANDE RÖRPINNE		1481	8752		11:3-11:4
13	111125	FRP, FJÄDRANDE PINNE ENKEL		7346	~13337		11:5
14	111130	PRYM, SPIRALSPÄNNSTIFT		7343	8750		11:6
14	111135	PRYM, SPIRALSPÄNNSTIFT, KRAFTIG		7344	8748		11:10
15	111138	CONEX					11:11
16	111140	CBH, CYL. SKALLBULT		1434			11:12
17	111150	HCB, CYL. SKALLBULT m. HÅL		1434			11:7
18	111160	HCP, CYL. PINNE m. TVÅ HÅL		1443			11:13

ROSTFRITT / SYRAFAST

1	211001	CP, CYL. PINNE	m6	7	2338	A2	11:42
1	211002	CP, CYL. PINNE	h8	7	2338	A1	11:42
1	211003	CP, CYL. PINNE	m6	7	2338	A4	11:43
1	211004	CP, CYL. PINNE	h8	7	2338	A4	11:43
4	211020	KP, KONISK PINNE		1	2339	A2	11:44
4	211021	KP, KONISK PINNE		1	2339	A4	11:44
13	211120	FRP, FJÄDRANDE RÖRPINNE		1481	8752	A2	11:41
14	211130	PRYM, SPIRALSPÄNNSTIFT		7343	8750	1.4310	11:45

ARTIKELLISTA

2013-2014

CYL. PINNE

CP DIN 7 / ISO 2338A

TOLERANS m6

(h8 - ISO 2338B samma pris)



DIM	1.5	2	2.5	3	4	5	6	8	10	12	14	16	20
Längd	C:A PRIS /100 ST												
4	X	X	X	X									
5	X	X	X	X									
6	X	X	X	X	X								
8	X	X	X	X	X	X							
10	X	X	X	X	X	X	X	X					
12	X	X	X	X	X	X	X	X	X				
14	X	X	X	X	X	X	X	X	X				
16	X	X	X	X	X	X	X	X	X	X			
18	X	X	X	X	X	X	X	X	X	X			
20	X	X	X	X	X	X	X	X	X	X	X		
22	X	X	X	X	X	X	X	X	X	X	X		
24	X	X	X	X	X	X	X	X	X	X	X	X	
25/26	X	X	X	X	X	X	X	X	X	X	X	X	
28	X	X	X	X	X	X	X	X	X	X	X	X	
30	X	X	X	X	X	X	X	X	X	X	X	X	
32		X	X	X	X	X	X	X	X	X	X	X	X
36		X	X	X	X	X	X	X	X	X	X	X	X
40		X	X	X	X	X	X	X	X	X	X	X	X
45			X	X	X	X	X	X	X	X	X	X	X
50			X	X	X	X	X	X	X	X	X	X	X
55				X	X	X	X	X	X	X	X	X	X
60				X	X	X	X	X	X	X	X	X	X
70							X	X	X	X	X	X	X
80							X	X	X	X	X	X	X
90							X	X	X	X	X	X	X
100							X	X	X	X	X	X	X
110								X	X	X	X	X	X
120								X	X	X	X	X	X

ÖVRIGA DIMENSIONER OCH LÄNGDER MOT FÖRFRÅGAN !

FÖRP	1.5	2	2.5	3	4	5	6	8	10	12	14	16	20
500ST	4-	4-	4-										
100ST				4-	6-	8-	10-	10-					
50ST									16-	20-	24-		
25ST												32-	40-

BESTÄLLNINGSEXEMPEL: 11100206030 - CP 6h8X30 STÅL

BESTÄLLNINGSEXEMPEL: 11100106030 - CP 6m6X30 STÅL

SWEBOLT AB

TEL 08 - 555 975 00 FAX 08 - 583 581 82

ARTIKELLISTA
2013-2014
CYLINDRISK PINNE HÄRDAD
CPK
TOLERANS m6
DIN 6325 ~ISO 8734A



DIM	1	1.5	2	2.5	3	4	5	6	8	10	12	14	16
Längd	C:A PRIS /100 ST												
3	X	X											
4	X	X											
5	X	X	X		X								
6	X	X	X	X	X								
8	X	X	X	X	X	X	X						
10	X	X	X	X	X	X	X	X					
12	X	X	X	X	X	X	X	X					
14		X	X	X	X	X	X	X	X				
16		X	X	X	X	X	X	X	X				
18			X	X	X	X	X	X	X				
20		X	X	X	X	X	X	X	X	X			
22			X	X	X		X						
24			X	X	X	X	X	X	X	X			
25			X	X	X					X			
26			X	X	X	X	X	X	X	X	X		
28			X	X	X	X	X	X	X	X	X		
30			X	X	X	X	X	X	X	X	X		
32			X	X	X	X	X	X	X	X	X		
34					X	X	X						
35								X	X	X			
36					X	X	X	X	X	X	X		
40					X	X	X	X	X	X	X	X	X
45						X	X	X	X	X	X	X	X
50						X	X	X	X	X	X	X	X
55							X	X	X	X	X	X	X
60						X	X	X	X	X	X	X	X
70								X	X	X	X	X	X
80								X	X	X	X	X	X
90									X	X	X	X	X
100									X	X	X	X	X
120												X	X

ÖVRIGA DIMENSIONER OCH LÄNGDER MOT FÖRFRÅGAN !

FÖRP.	1	1.5	2	2.5	3	4	5	6	8	10	12	14	16
500 ST	3-	3-	4-	4-	5-	6-	6-						
200 ST						30-	24-	10-	10-				
100 ST								40-	40-	12-	12-		
25 ST												40-	16-

BESTÄLLNINGSEXEMPEL: 11100302005 - CPK 2m6X5 HÄRDAD

SWEBOLT AB
TEL 08 - 555 975 00 FAX 08 - 583 581 82

ARTIKELLISTA
2013-2014
FJÄDRANDE RÖRPINNAR
FRP DIN 1481



DIM	1.5	2	2.5	3	3.5	4	4.5	5	6	7	8	10
Dy MIN	1.7	2.3	2.8	3.3	3.8	4.4	4.9	5.4	6.4		8.5	10.5
Dy MAX	1.8	2.4	2	3.5	4	4.6	5.1	5.6	6.7		8.8	10.8
di	1.1	1.5	1.8	2.1	2.3	2.8	2.9	3.4	3.9		5.5	6.5
Längd	PRIS/100 ST											
4	X	X	X	X	X	X						
5	X	X	X	X	X	X						
6	X	X	X	X	X	X	X	X				
8	X	X	X	X	X	X	X	X	X			
10	X	X	X	X	X	X	X	X	X		X	X
12	X	X	X	X	X	X	X	X	X		X	X
14		X	X	X	X	X	X	X	X		X	X
15												
16	X	X	X	X	X	X	X	X	X		X	X
18	X	X	X	X	X	X	X	X	X		X	X
20	X	X	X	X	X	X	X	X	X		X	X
22		X	X	X	X	X	X	X	X		X	X
24		X	X	X	X	X	X	X	X		X	X
25											X	
26		X		X	X	X	X	X	X		X	X
28		X		X	X		X	X	X	X	X	X
30		X	X	X	X	X	X	X	X	X	X	X
32				X	X	X	X	X	X		X	X
34											X	
35												
36				X		X	X	X	X		X	X
38												X
40			X	X	X	X	X	X	X	X	X	X
45						X		X	X		X	X
50						X	X	X	X	X	X	X
55								X	X	X	X	X
60					X	X	X	X	X	X	X	X
65								X	X		X	X
70								X	X		X	X
75								X	X	X	X	X
80						X		X	X	X	X	X
85									X		X	X
90									X	X	X	X
95												
100									X	X	X	X
110												
120												
130												
140												
150												
160												
180												

ÖVRIGA DIMENSIONER OCH LÄNGDER MOT FÖRFRÅGAN !

BESTÄLLNINGSEXEMPEL: 11112008032 - FRP 8X32 STÅL

SWEBOLT AB

TEL 08 - 555 975 00 FAX 08 - 583 581 82

ARTIKELLISTA
2013-2014
FJÄDRANDE RÖRPINNAR
FRP DIN 1481



DIM	12	13	14	16	18	20
Dy MIN	12.5	13.5	14.4	16.5	18.5	20.5
Dy MAX	12.8	13.8	14.8	16.8	18.9	20.9
di	7.5	8.5	8.5	10.5	11.5	12.5
Längd	PRIS/100 ST					
10						
12						
14						
15						
16	X					
18	X	X				
20	X	X				
22						
24	X	X				
25						
26	X	X				
28	X	X				
30	X	X				
32	X	X				
34						
35						
36	X	X				
38						
40	X	X				
45	X	X				
50	X	X				
55	X	X				
60	X	X				
65	X	X				
70	X	X				
75	X	X		X		
80	X	X				
85						
90	X	X				
95						
100	X	X				X
110	X	X				
120	X	X				
130						
140						
150						
160						
180						
200						
220						
240						
260						

ÖVRIGA DIMENSIONER OCH LÄNGDER MOT FÖRFRÅGAN !

BESTÄLLNINGSEXEMPEL: 11112012032 - FRP 12x32 STÅL

SWEBOLT AB

TEL 08 - 555 975 00 FAX 08 - 583 581 82

ARTIKELLISTA

2013-2014

FJÄDRANDE RÖRPINNAR

FRP DIN 1481

ROSTFRI A2

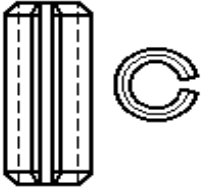

DIM	1.5	2	2.5	3	3.5	4	4.5	5	6	8	10
Dy MIN	1.7	2.3	2.8	3.3	3.8	4.4	4.9	5.4	6.4	8.5	10.5
Dy MAX	1.8	2.4	2	3.5	4	4.6	5.1	5.6	6.7	8.8	10.8
d _i	1.1	1.5	1.8	2.1	2.3	2.8	2.9	3.4	3.9	5.5	6.5
Längd	PRIS/100 ST										
4	X	X	X	X	X	X					
5	X	X	X	X	X	X					
6	X	X	X	X	X	X	X	X			
8	X	X	X	X	X	X	X	X			
10	X	X	X	X	X	X	X	X	X	X	X
12	X	X	X	X	X	X	X	X	X	X	X
14	X	X	X	X	X	X	X	X	X	X	X
15											
16	X	X	X	X	X	X	X	X	X	X	X
18	X	X	X	X	X	X	X	X	X	X	
20	X	X	X	X	X	X	X	X	X	X	X
22		X	X	X	X		X	X	X	X	X
24		X	X	X	X	X	X	X	X	X	X
25											
26		X	X	X	X	X	X	X	X	X	X
28		X	X	X	X	X	X	X	X	X	
30		X	X	X	X	X	X	X			
32				X	X	X	X	X	X	X	X
34										X	X
35											
36				X	X	X	X	X	X	X	X
38											
40				X	X	X	X	X	X	X	X
45						X	X	X	X	X	X
50						X	X	X	X	X	X
55								X	X	X	X
60								X	X	X	X
65								X	X	X	X
70								X	X	X	X
75								X	X	X	X
80								X	X	X	X
85										X	X
90										X	X
95										X	X
100										X	X
110											
120											
130											
140											
150											
160											
180											

ÖVRIGA DIMENSIONER OCH LÄNGDER MOT FÖRFRÅGAN !

BESTÄLLNINGSEXEMPEL: 21112006024 - FRP 6x24 A2

SWEBOLT AB

TEL 08 - 555 975 00 FAX 08 - 583 581 82

11:41

ARTIKELLISTA

2013-2014

CYL. PINNE ROSTFRI A2

CP DIN 7 / ISO 2338A

TOLERANS m6

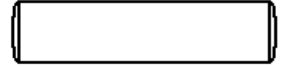

DIM	1	1.5	2	2.5	3	4	5	6	8	10	12	14	16
Längd	C:A PRIS /100 ST												
3	X												
4	X	X	X										
5		X	X			X							
6	X	X	X	X	X	X							
8		X	X		X	X							
10	X				X	X	X						
12		X	X	X	X	X	X						
14			X		X	X			X				
16		X			X	X		X					
18					X	X							
20		X		X	X	X	X		X				
22													
24				X	X	X							
25				X									
26													
28					X				X				
30					X	X		X	X				
32					X		X	X	X				
36					X			X					
40					X			X	X				
45								X					
50								X		X			
55								X					
60													
70													
80													
90											X		
100										X			
110													
120													

ÖVRIGA DIMENSIONER OCH LÄNGDER MOT FÖRFRÅGAN !

FÖRP	1	1.5	2	2.5	3	4	5	6	8	10	12	14	16
500ST		5-	6-	6-									
100ST					6-	6-	8-	10-	14-				
50ST										20-	20-	24-	
25ST													40-

BESTÄLLNINGSEXEMPEL: 21100104018 - CRP 4m6X18 A2

SWEBOLT AB

TEL 08 - 555 975 00 FAX 08 - 583 581 82

11:42

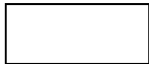
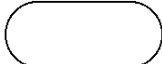
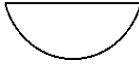
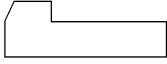
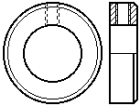
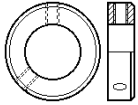
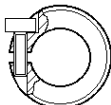
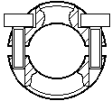
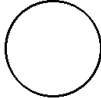
- 1 - 	- 2 - 	- 3 - 	- 4 - 
- 5 - 	- 6 - 	- 7 - 	- 8 - 
- 9 - 	- 10 -	- 11 -	- 12 -
- 13 -	- 14 -	- 15 -	- 16 -
- 17 -	- 18 -	- 19 -	- 20 -
- 21 -	- 22 -	- 23 -	- 24 -
- 25 -	- 26 -	- 27 -	- 28 -
- 29 -	- 30 -	- 31 -	- 32 -

SWEBOLT AB

TEL. 08-584 909 60 FAX. 08-583 581 82

PRODUKTER I STÅL

1	112000	TK, TVÄR KIL		6885B			12:2
2	112010	RK, RUNDAD KIL, H9		6885A			12:1
2	112011	RK, RUNDAD KIL, H7		6885A			12:1
3	112020	WK, WOODRUFFKIL		6888			12:2
4	112030	SK, SKALLKIL		6887			12:3
5	112040	SR, STÄLLRING m. STOPPSKRUV	705				12:4
6	112050	SR, STÄLLRING m. STOPPSKRUV					12:4
	112051	SR, KLÄMRING					12:4
7	112100	LR, LÅSRING					12:5
8	112110	LR, LÅSRING, DUBBEL					12:5
9	112120	KULA		5401			12:6

ROSTFRITT / SYRAFAST

1	212000	TK, TVÄRKIL		6885B	A4		12:40
2	212009	RK, RUNDKIL		6885A	A2		12:41
2	212010	RK, RUNDKIL		6885A	A4		12:41
5	212040	SR, STÄLLRING m. STOPPSKRUV	705		A2		12:42
9	212120	KULA		5401	A2		12:43

ARTIKELLISTA

2013-2014

RK KIL

DIN 6885A

TOLERANS H9



DIM	2x2	3x3	4x4	5x5	6x6	8x7	10x8	12x8	14x9	16x10	18x11	20x12	22x14	25x14
6	X													
8	X	X	X											
10	X	X	X	X	X									
12	X	X	X	X	X									
14	X	X	X	X	X									
16	X	X	X	X	X	X								
18	X	X	X	X	X	X								
20	X	X	X	X	X	X	X							
22		X	X	X	X	X								
25		X	X	X	X	X	X	X						
28			X	X	X	X	X	X	X					
30			X	X	X	X	X	X						
32			X	X	X	X	X	X	X					
35				X	X									
36			X	X	X	X	X	X	X					
40			X	X	X	X	X	X	X	X	X			
45				X	X	X	X	X	X	X	X			
50				X	X	X	X	X	X	X	X	X		
56					X	X	X	X	X	X	X	X		
60						X	X	X	X	X	X	X		
63					X	X	X	X	X	X	X	X	X	
70					X	X	X	X	X	X	X	X	X	X
75								X						
80					X	X	X	X	X	X	X	X	X	X
90						X	X	X	X	X	X	X	X	X
100					X	X	X	X	X	X	X	X	X	X
110						X	X	X	X	X	X	X	X	X
120						X	X	X	X	X	X			
125								X	X	X	X	X	X	X
140							X	X	X	X	X	X	X	X
150								X	X			X		
160									X	X	X	X	X	X
180									X	X	X	X	X	X
200									X		X	X	X	X
220												X		
250												X	X	

KRYSSMARKERADE ARTIKLAR MOT FÖRFRÅGAN !

FÖRP	2x2	3x3	4x4	5x5	6x6	8x7	10x8	12x8	14x9	16x10	18x11	20x12	22x14	25x14
200 ST	6-	8-	8-	10-	10-									
100 ST			25-	25-	14-	20-	25-							
50 ST						80-	80-	25-	30-					
25 ST								80-	45-	50-	63-			
10 ST													63-	
5 ST													160-	
1 ST														70-

BESTÄLLNINGSEXEMPEL: 11201010030 - RK KIL 10X8X30 H9 STÅL

SWEBOLT AB

TEL 08 - 555 975 00 FAX 08 - 583 581 82

ARTIKELLISTA

2013-2014

RK KIL A4

DIN 6885A

TOLERANS H9

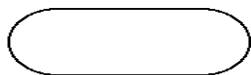

DIM	3x3	4x4	5x5	6x6	8x7	10x8	12x8	14x9	16x10	18x11	20x12	22x14	25x14
6													
8													
10													
12		X	X										
14													
16			X	X									
18				X									
20		X	X	X	X								
22													
25			X	X									
28													
30				X	X	X							
32													
35				X									
36													
40					X	X							
45													
50						X							
56													
60						X	X						
63													
70													
80													
90													
100													
110													
120													
125													
140													
150													
160													
180													
200													
220													
250													

KRYSSMARKERADE ARTIKLAR MOT FÖRFRÅGAN !

FÖRP	3x3	4x4	5x5	6x6	8x7	10x8	12x8	14x9	16x10	18x11	20x12	22x14	25x14
200 ST	10-	12-	12-										
100 ST		25-	25-	14-	20-	25-							
50 ST					80-	80-	25-	30-					
25 ST							80-	45-	50-	63-			
10 ST											63-		
5 ST											160-		
1 ST													70-

BESTÄLLNINGSEXEMPEL: 21201006018 - RK KIL 6x6x18 A4

SWEBOLT AB

TEL 08 - 555 975 00 FAX 08 - 583 581 82

12:41

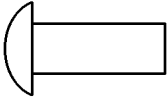
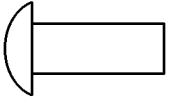
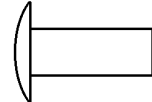
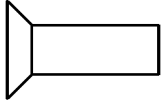
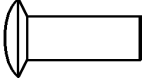
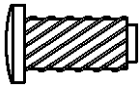
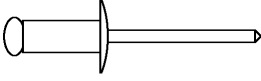
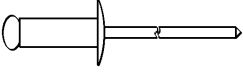
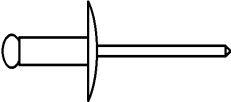
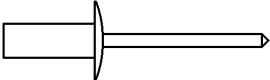
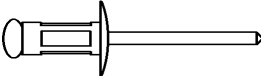
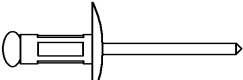
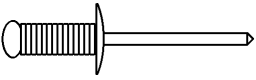
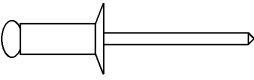
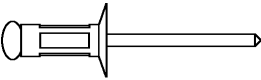
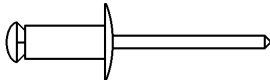
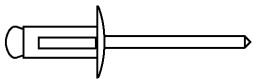
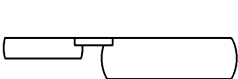
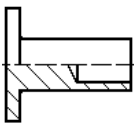
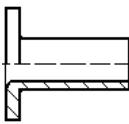
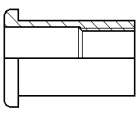
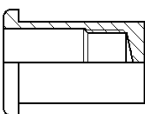
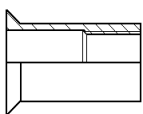
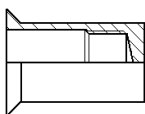
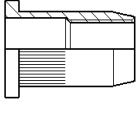
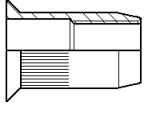
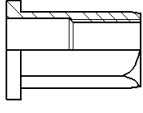
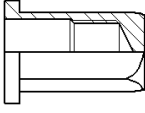
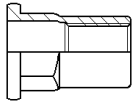
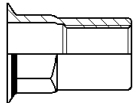
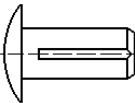
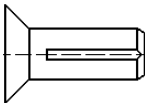
- 1 - 	- 2 - 	- 3 - 	- 4 - 
- 5 - 	- 6 - 	- 7 - 	- 8 - 
- 9 - 	- 10 - 	- 11 - 	- 12 - 
- 13 - 	- 14 - 	- 15 - 	- 16 - 
- 17 - 	- 18 - 	- 19 - 	- 20 - 
- 21 - 	- 22 - 	- 23 - 	- 24 - 
- 25 - 	- 26 - 	- 27 - 	- 28 - 
- 29 - 	- 30 - 	- 31 - 	- 32 - 

SWEBOLT AB

TEL. 08-584 909 60 FAX. 08-583 581 82

PRODUKTER I STÅL

1	113000	KN, KULLRIG NIT	660		STÅL	OBEH	13:100
2	113001	KNH, KULLRIG NIT, HALVRUND	674		STÅL	OBEH	13:102
3	113002	KNL, KULLRIG NIT, LÅG	124		STÅL	OBEH	13:102
4	113010	FN, FÖRSÄNKT NIT	661		STÅL	OBEH	13:101
5	113015	KFN, KULLERFÖRSÄNKT NIT	662		STÅL	OBEH	13:104
6	113020	KDS, DRIVNIT			STÅL	FÖRNICKL.	13:105

BLINDNIT

KULLRIGT HUVUD

7	113200	KBL-AL/ST	ALU		STÅL		13:1-2
7	113201	KBL-AL/AL	ALU		ALU		13:3
7	113203	KBL-AL/RF	ALU		ROSTFRI		13:4
7	113202	KBL-ST/ST	STÅL		STÅL		13:5
7	113204	KBL-RF/RF	ROSTFRI		ROSTFRI		13:6
7	113205	KBL-KO/ST	KOPPAR		STÅL		13:17
7	113206	KBL-KO/BR	KOPPAR		BRONS		13:18
7	113207	KBL-MO/ST	MONEL		STÅL		13:9
7	113208	KBL-MO/RF	MONEL		ROSTFRI		13:10

KULLRIG LACKERAD NIT

					RAL		
7	113221	KBL-AL/ST, VIT	ALU		STÅL	9010	13:11
7	113222	KBL-AL/ST, SVART	ALU		STÅL	9005	13:11
7	113223	KBL-AL/ST, GRÖNBLÅ	ALU		STÅL	5001	13:11
7	113224	KBL-AL/ST, MELLANBLÅ	ALU		STÅL	5007	13:11
7	113225	KBL-AL/ST, ORANGE	ALU		STÅL	2004	13:12
7	113226	KBL-AL/ST, KLARRÖD	ALU		STÅL	3000	13:12
7	113227	KBL-AL/ST, VINRÖD	ALU		STÅL	3005	13:12
7	113228	KBL-AL/ST, MÖRKRÖD	ALU		STÅL	3007	13:12
7	113229	KBL-AL/ST, LJUSBEIGE	ALU		STÅL	1015	13:13
7	113230	KBL-AL/ST, BEIGE	ALU		STÅL	1001	13:13
7	113231	KBL-AL/ST, BRUN	ALU		STÅL	8014	13:13
7	113232	KBL-AL/ST, LJUSGRÅ	ALU		STÅL	7038	13:13
7	113233	KBL-AL/ST, RAPSGUL	ALU		STÅL	1021	13:14
7	113234	KBL-AL/ST, GULDGUL	ALU		STÅL	1004	13:14
7	113235	KBL-AL/ST, GRÖN	ALU		STÅL	6002	13:14
7	113236	KBL-AL/ST, ÄRGGRÖN	ALU		STÅL	6021	13:14
7	113237	KBL-AL/ST, MOSSGRÖN	ALU		STÅL	6005	13:14

KULLRIGT HUVUD, SPLINT, LOSSNAR VID NITNING

7	113260	KBLU-AL/ST	ALU		STÅL		13:37
7	113263	KBLU-KO/ST	KOPPAR		STÅL		13:38
7	113262	KBLU-ST/ST	STÅL		STÅL		13:39
7	113263	KBLU-AL/ST, VIT	ALU		STÅL	9010	13:40

SWEBOLT AB

TEL. 08-584 909 60 FAX. 08-583 581 82

BILD	ART.GR.	BENÄMNING	NIT	ISO	KVAL	YTBEH	SIDA
KULLRIGT HUVUD, EXTRA LÅNG KLÄMLÄNGD							
8	113240	KBLEL-AL/ST	ALU		STÅL		13:34
8	113251	KBLEL-AL/ST, VIT	ALU		STÅL	9010	13:35
STORT KULLRIGT HUVUD, SPLINT KVAR							
9	113350	SKBL-AL/ST	ALU		STÅL		13:7
9	113351	SKBL-AL/AL	ALU		ALU		13:3
9	113352	SKBL-ST/ST	STÅL		STÅL		13:22
9	113355	SKBL-AL/RF	ALU		ROSTFRI		13:4
9	113353	SKBL-RF/RF	ROSTFRI		ROSTFRI		13:24
9	113354	SKBL-KO/RF	KOPPAR		ROSTFRI		13:23
9	113361	SKBL-AL/ST, VIT	ALU		STÅL	9010	13:25
9	113362	SKBL-AL/ST, SVART	ALU		STÅL	9005	13:25
EXTRA STORT KULLRIGT HUVUD							
9	113380	ESKBL-AL/ST	ALU		STÅL		13:44
KULLRIG TRYCKTÄTAD NIT							
10	113290	TKBL-AL/ST	ALU		STÅL		13:26
10	113296	TKBLG-AL/ST, m. GUMMIBRICKA	ALU		STÅL		13:32
10	113291	TKBL-AL/AL	ALU		ALU		13:27
10	113292	TKBL-AL/RF	ALU		ROSTFRI		13:28
10	113293	TKBL-KO/ST	KOPPAR		STÅL		13:29
10	113294	TKBL-ST/ST	STÅL		STÅL		13:30
10	113295	TKBL-RF/RF	ROSTFRI		ROSTFRI		13:31
10	113301	TKBL-AL/ST, VIT	ALU		STÅL	9010	13:33
10	113302	TKBL-AL/ST, SVART	ALU		STÅL	9005	13:33
KULLRIG TRYCKTÄTAD NIT, STORT HUVUD							
10	113310	STKBL-AL/ST	ALU		STÅL		13:26
KULLRIG SKALLE, MULTIGRIP							
11	113385	KBLMG-AL/ST	ALU		STÅL		13:36
11	113386	KBLMG-AL/RF	ALU		ROSTFRI		13:36
STOR SKALLE MULTIGRIP							
12	113390	SKBLMG-AL/ST	ALU		STÅL		13:36
BLINDNIT FÖR BOTTENHÅL, RÄFFLAD							
13	113410	KBLBH-AL/ST	ALU		STÅL		13:47
FÖRSÄNKT BLINDNIT							
14	113500	FBL-AL/ST	ALU		STÅL		13:15
14	113502	FBL-KO/ST	KOPPAR		STÅL		13:17
14	113503	FBL-KO/RF	KOPPAR		ROSTFRI		13:18
14	113504	FBL-RF/RF	ROSTFRI		ROSTFRI		13:18
14	113505	FBL-KO/NI	KOPPAR		NICKEL		13:18
14	113501	FBL-ST/ST	STÅL		STÅL		13:16
14	113511	FBL-AL/ST, VIT	ALU		STÅL	9010	13:19
14	113512	FBL-AL/ST, SVART	ALU		STÅL	9005	13:20

SWEBOLT AB

TEL. 08-584 909 60 FAX. 08-583 581 82

BILD	ART.GR.	BENÄMNING	NIT	ISO	KVAL	YTBEH	SIDA
FÖRSÄNKT TRYCKTÄT BLINDNIT							
14	113550	TFBL-AL/ST	ALU		STÅL		13:51
14	113551	TFBL-KO/ST	KOPPAR		STÅL		13:52
FÖRSÄNKT MULTIGRIP, ERSÄTTER FLERA LÄNGDER							
15	113510	FBLMG-AL/ST	ALU		STÅL		13:48
15	113511	FBLMG-AL/ST, SVART	ALU		STÅL	9005	13:49
FÖRSÄNKT BLINDNIT, HUVUD LOSSNAR							
14	113520	FBLU-AL/ST	ALU		STÅL		13:57
14	113521	FBLU-KO/ST	KOPPAR		STÅL		13:58
14	113522	FBLU-ST/ST	STÅL		STÅL		13:59
FÖR MJUKA MATERIAL, KULLRIGT HUVUD							
16	113330	KBLSM-AL/ST	ALU		STÅL		13:42
16	113331	SKBLSM-AL/ST, STORT HUVUD	ALU		STÅL		13:43
FÖR MJUKA MATERIAL, EXTRA LÅNG, KULLRIGT HUVUD							
11	113332	KBLSMEL-AL/ST	ALU		STÅL		13:45
ROSETTNIT CYL. HUVUD							
17	113600	RKBL-AL/AL	ALU		ALU		13:53
17	113601	RKBL-AL/AL, VIT	ALU		ALU	9010	13:54
17	113602	RKBL-AL/AL, SVART	ALU		ALU	9005	13:55
EXPANDERNIT FÖR SPRÖDA MATERIAL							
17	113650	EKBL-AL/ST	ALU		STÅL		13:56
18		SKYDDSLÖCK FÖR BLINDNIT			PLAST		13:60
<u>BLINDNITMUTTER, BM</u>							
21	113700	PBMÖS, PLAN SKALLE, ÖPPEN			STÅL	OBEH	13:70
21	113701	PBMÖS, PLAN SKALLE, ÖPPEN			STÅL	FZG	13:70
21	113702	PBMÖS, PLAN SKALLE, ÖPPEN			STÅL	FZB	13:70
22	113705	PBMSS, PLAN SKALLE, SLUTEN			STÅL	OBEH	13:70
22	113706	PBMSS, PLAN SKALLE, SLUTEN			STÅL	FZG	13:70
22	113707	PBMSS, PLAN SKALLE, SLUTEN			STÅL	FZB	13:70
21	113715	PBMSÖS, PLAN SKALLE SMALLGRIP, ÖPPEN			STÅL	OBEH	13:71
21	113716	PBMSÖS, PLAN SKALLE SMALLGRIP, ÖPPEN			STÅL	FZG	13:71
21	113717	PBMSÖS, PLAN SKALLE SMALLGRIP, ÖPPEN			STÅL	FZB	13:71
22	113710	PBMSSS, PLAN SKALLE SMALLGRIP, SLUTEN			STÅL	OBEH	13:71
22	113711	PBMSSS, PLAN SKALLE SMALLGRIP, SLUTEN			STÅL	FZG	13:71
22	113712	PBMSSS, PLAN SKALLE SMALLGRIP, SLUTEN			STÅL	FZB	13:71
21	113720	PBMÖAL, PLAN SKALLE, ÖPPEN			ALU		13:72
22	113721	PBMSAL, PLAN SKALLE, SLUTEN			ALU		13:72
21	113724	PBMSÖAL, PLAN SKALLE SMALLGRIP, ÖPPEN			ALU		13:72
22	113725	PBMSSAL, PLAN SKALLE SMALLGRIP, SLUTEN			ALU		13:72

SWEBOLT AB

TEL. 08-584 909 60 FAX. 08-583 581 82

BILD	ART.GR.	BENÄMNING	NIT	ISO	KVAL	YTBEH	SIDA
23	113750	FBMÖS, FÖRSÄNKTK SKALLE, ÖPPEN			STÅL	OBEH	13:73
23	113751	FBMÖS, FÖRSÄNKTK SKALLE, ÖPPEN			STÅL	FZG	13:73
23	113752	FBMÖS, FÖRSÄNKTK SKALLE, ÖPPEN			STÅL	FZB	13:73
24	113755	FBMSS, FÖRSÄNKTK SKALLE, SLUTEN			STÅL	OBEH	13:73
24	113756	FBMSS, FÖRSÄNKTK SKALLE, SLUTEN			STÅL	FZG	13:73
24	113757	FBMSS, FÖRSÄNKTK SKALLE, SLUTEN			STÅL	FZB	13:73
23	113760	FBMÖSS, FÖRSÄNKTK SKA. SMALLGRIP, ÖPPEN			STÅL	OBEH	13:74
23	113761	FBMÖSS, FÖRSÄNKTK SKA. SMALLGRIP, ÖPPEN			STÅL	FZG	13:74
23	113762	FBMÖSS, FÖRSÄNKTK SKA. SMALLGRIP, ÖPPEN			STÅL	FZB	13:74
24	113765	FBMSSS, FÖRSÄNKTK SKA. SMALLGRIP, SLUTEN			STÅL	OBEH	13:74
24	113766	FBMSSS, FÖRSÄNKTK SKA. SMALLGRIP, SLUTEN			STÅL	FZG	13:74
24	113767	FBMSSS, FÖRSÄNKTK SKA. SMALLGRIP, SLUTEN			STÅL	FZB	13:74
21	113770	FBMÖAL, FÖRSÄNKTK ÖPPEN			ALU		13:75
22	113772	FBMSAL, FÖRSÄNKTK SLUTEN			ALU		13:75
23	113774	FBMÖSAL, FÖRSÄNKTK ÖPPEN SMALLGRIP			ALU		13:75
24	111776	FBMSSAL, FÖRSÄNKTK SLUTEN SMALLGRIP			ALU		13:75
23	113780	FBMÖRS, FÖRSÄNKTK ÖPPEN			ROSTFRI		13:76
23	113782	FBMÖRSR, FÖRSÄNKTK ÖPPEN SMALLGRIP			ROSTFRI		13:76
23	113800	SFBMS, SJÄLVFÖRSÄNKANDE ÖPPEN			STÅL	OBEH	13:77
23	113801	SFBMS, SJÄLVFÖRSÄNKANDE ÖPPEN			STÅL	FZG	13:77
23	113802	SFBMS, SJÄLVFÖRSÄNKANDE ÖPPEN			STÅL	FZB	13:77
23	113810	SFBMRS, SJÄLVFÖRSÄNKANDE, ÖPPEN			ROSTFRI		13:76
25	113850	PBMÖRS, PLAN SKALLE, RILLAD, ÖPPEN			STÅL	OBEH	13:78
25	113851	PBMÖRS, PLAN SKALLE, RILLAD, ÖPPEN			STÅL	FZG	13:78
25	113852	PBMÖRS, PLAN SKALLE, RILLAD, ÖPPEN			STÅL	FZB	13:78
26	113855	FBMÖRS, FÖRSÄNKTK SKALLE, RILLAD, ÖPPEN			STÅL	OBEH	13:78
26	113856	FBMÖRS, FÖRSÄNKTK SKALLE, RILLAD, ÖPPEN			STÅL	FZG	13:78
26	113857	FBMÖRS, FÖRSÄNKTK SKALLE, RILLAD, ÖPPEN			STÅL	FZB	13:78
27	113900	P6BMÖS, PLAN 6-KANT, ÖPPEN			STÅL	OBEH	13:79
27	113901	P6BMÖS, PLAN 6-KANT, ÖPPEN			STÅL	FZG	13:79
27	113902	P6BMÖS, PLAN 6-KANT, ÖPPEN			STÅL	FZB	13:79
28	113905	P6BMSS, PLAN 6-KANT, SLUTEN			STÅL	OBEH	13:79
28	113906	P6BMSS, PLAN 6-KANT, SLUTEN			STÅL	FZG	13:79
28	113907	P6BMSS, PLAN 6-KANT, SLUTEN			STÅL	FZB	13:79
21	113910	RBMS, RÖRANPASSAD			STÅL	OBEH	13:80
21	113911	RBMS, RÖRANPASSAD			STÅL	FZG	13:80
21	113912	RBMS, RÖRANPASSAD			STÅL	FZB	13:80

SWEBOLT AB

TEL. 08-584 909 60 FAX. 08-583 581 82

BILD	ART.GR.	BENÄMNING	NIT	ISO	KVAL	YTBEH	SIDA
29	113915	P6BMKOS, PLAN KORT, 6-KANT, ÖPPEN			STÅL	OBEH	13:80
29	113916	P6BMKOS, PLAN KORT, 6-KANT, ÖPPEN			STÅL	FZG	13:80
29	113917	P6BMKOS, PLAN KORT, 6-KANT, ÖPPEN			STÅL	FZB	13:80
30	113920	SF6BMOS, SJÄLVFÖRSÄNKANDE, ÖPPEN			STÅL	OBEH	13:81
30	113921	SF6BMOS, SJÄLVFÖRSÄNKANDE, ÖPPEN			STÅL	FZG	13:81
30	113922	SF6BMOS, SJÄLVFÖRSÄNKANDE, ÖPPEN			STÅL	FZB	13:81
30	113925	SF6BMOAL, SJÄLVFÖRSÄNKANDE, ÖPPEN			ALU		13:81
26	113935	SFBMROS, SJÄLVFÖRS. M. RILLOR, ÖPPEN STÅL			OBEH	13:82	
26	113936	SFBMROS, SJÄLVFÖRS. M. RILLOR, ÖPPEN STÅL			FZG	13:82	
26	113937	SFBMROS, SJÄLVFÖRS. M. RILLOR, ÖPPEN STÅL			FZB	13:82	
32	113040	KNR, KULLRIG NIT, RÄFFLAD	1476	8746			
31		KNR, RÄFFLAD KULLRIG NIT	1476		STÅL		13:106
32		FNR, RÄFLAD FÖRSÄNKAT NIT	1477		STÅL		13:107

ROSTFRITT / SYRAFAST

1	213000	KN, KULLRIG NIT	660		A2		13:110
4	213010	FN, FÖRSÄNKAT NIT	661		A2		13:111
4	213011	FN, FÖRSÄNKAT NIT	661		A4		13:111
6	213020	KDS, DRIVNIT			A2		13:112
6	213021	KDS, DRIVNIT			A4		13:112
21	113730	PBMÖRS, PLAN SKALLE ÖPPEN			ROSTFRI		13:72
21	113732	PBMÖRSRS, PLAN SKALLE SMALLGRIP, ÖPPEN			ROSTFRI		13:72

MÄSSING

1	313000	KN, KULLRIG NIT	660				13:120
4	313010	FN, FÖRSÄNKAT NIT	661				13:121
5	313015	KFN, KULLERFÖRSÄNKAT NIT	662				13:122
19	313060	RN, RÖRNIT	7339			FÖRNICKL.	13:123
20	313065	RN, RÖRNIT	7340A				13:124

KOPPAR

1	513000	KN, KULLRIG NIT	660				13:130
4	513010	FN, FÖRSÄNKAT NIT	661				13:131
5	513015	KFN, KULLERFÖRSÄNKAT NIT	662				13:132

SWEBOLT AB

TEL. 08-584 909 60 FAX. 08-583 581 82

ALUMINIUM

1	613000	KN, KULLRIG NIT	660				13:140
2	613001	KNL, KULLRIG NIT, LÅG	674				13:141
4	613010	FN, FÖRSÄNKAT NIT	~661				13:142
5	613015	KFN, KULLERFÖRSÄNKAT NIT	662				13:143

VERKTYG FÖR BLINDNIT / BLINDNITMUTTER

13950	BLINDNITSTÅNG, BM 65	13:86
13951	BLINDNITSTÅNG, BM 66	13:87
13952	BLINDNITSTÅNG, BM 67	13:88
13953	BLINDNITSTÅNG, BM 90	13:89
13954	BLINDNITSTÅNG, BM 92	13:90
13955	BLINDNITSTÅNG, BM 93	13:91
13956	BLINDNITSVERKTYG, EL	13:92
13957	BLINDNITSVERKTYG, LUFT	13:93
13958	TÅNG FÖR BLINDNITMUTTER, TR 100	13:94
13958	TÅNG FÖR BLINDNITMUTTER, TR 200	13:95
13958	TÅNG FÖR BLINDNITMUTTER, TR 300	13:96



ARTIKELLISTA

2013-2014

BLINDNIT KULLRIGT HUVUD NIT ALUMINIUM / SPLINT STÅL FÖRZINKAD DIN 7337 KBL-AL/ST

C:A PRIS/100 ST								
Diameter	Längd	Pris	Förp.	Grepp	Splintdia.	Skalldiam.	Skallhöjd	Borrdiam.
Ø 2.4	4	X	1000/8000	0,5-2,0	1,45	5,00	0,55	2,50
	6	X	1000/8000	2,0-4,0				
	8	X	1000/8000	4,0-6,0				
	10	X	1000/8000	6,0-8,0				
Ø 3.0	5	X	500/4000	0,5-2,5	1,80	6,50	0,80	3,10
	6	X	500/4000	1,5-3,5				
	7	X	500/4000	1,5-4,5				
	8	X	500/4000	3,5-5,5				
	10	X	500/4000	5,5-7,0				
	12	X	500/4000	7,0-9,0				
	14	X	500/4000	9,0-11,0				
	16	X	500/4000	11,0-13,0				
18	X	500/4000	13,0-15,0					
Ø 3.2	5	X	500/4000	0,5-2,5	1,80	6,50	0,80	3,30
	6	X	500/4000	1,5-2,5				
	8	X	500/4000	3,5-5,5				
	10	X	500/4000	5,5-7,0				
	12	X	500/4000	7,0-9,0				
	15	X	500/4000	9,0-12,0				
	18	X	500/4000	12,0-15,0				
20	X	500/4000	15,0-17,0					
Ø 4.0	5	X	500/4000	0,5-2,5	2,20	8,00	1,00	4,10
	6	X	500/4000	1,5-3,0				
	7	X	500/4000	3,0-4,5				
	8	X	500/4000	3,0-5,0				
	10	X	500/4000	5,0-6,5				
	12	X	500/4000	6,5-8,5				
	14	X	500/4000	8,5-10,5				
	16	X	500/4000	10,5-12,5				
	18	X	500/4000	12,5-14,5				
	20	X	500/4000	14,5-16,5				
25	X	250/2000	16,5-21,5					
30	X	250/2000	21,5-26,0					
Ø 4.8	6	X	500/3000	0,5-3,0	2,75	9,50	1,10	4,90
	8	X	500/3000	3,0-4,5				
	10	X	500/3000	4,5-6,0				
	12	X	500/3000	6,0-8,0				
	14	X	500/3000	8,0-10,0				
16	X	250/2000	10,0-12,0					

ÖVRIGA DIMENSIONER OCH LÄNGDER MOT FÖRFRÅGAN !

BESTÄLLNINGSEXEMPEL: 11320032100 - KBL-AL/ST 3.0X10

SWEBOLT AB

TEL 08 - 555 975 00 FAX 08 - 583 581 82

ARTIKELLISTA
2013-2014
BLINDNIT KULLRIGT HUVUD
NIT ALUMINIUM / SPLINT STÅL FÖRZINKAD
DIN 7337
KBL-AL/ST



C:A PRIS/100 ST								
Diameter	Längd	Pris	Förp.	Grepp	Splintdia.	Skalldiam.	Skallhöjd	Borrdiam.
Ø 4.8	18	X	250/2000	12,0-14,0	2,75	9,50	1,10	4,90
	21	X	250/2000	14,0-17,0				
	24	X	200/1200	17,0-20,0				
	27	X	200/1200	20,0-23,0				
	30	X	200/1200	23,0-25,0				
	32	X	150/900	25,0-27,0				
	35	X	150/900	27,0-30,0				
	40	X	150/900	30,0-35,0				
	45	X	100/600	35,0-40,0				
	50	X	10/600	40,0-45,0				
Ø 5.0	6	X	500/3000	0,5-2,5	2,75	9,50	1,10	5,10
	8	X	500/3000	3,0-4,5				
	10	X	500/3000	4,5-6,0				
	12	X	500/3000	6,0-8,0				
	14	X	500/3000	8,0-10,0				
	16	X	250/2000	10,0-12,0				
	18	X	250/2000	12,0-14,0				
	20	X	200/1200	14,0-16,0				
	25	X	200/1200	16,0-21,0				
	30	X	200/1200	21,0-25,0				
	35	X	200/1200	25,0-30,0				
	40	X	150/900	30,0-35,0				
	45	X	100/600	35,0-40,0				
	50	X	100/600	40,0-45,0				
Ø 6.0	8	X	250/2000	2,0-4,0	2,95	12,00	1,50	6,10
	10	X	250/2000	4,0-6,0				
	12	X	250/1500	6,0-8,0				
	14	X	250/1500	8,0-10,0				
	16	X	200/1200	10,0-11,0				
	18	X	200/1200	11,0-13,0				
	20	X	200/1200	13,0-15,0				
	25	X	200/1200	15,0-20,0				
	30	X	150/900	25,0-30,0				
	35	X	100/900	30,0-35,0				
Ø 6.4	12	X	250/1500	2,0-6,0	2,95	13,00	1,80	6,50
	15	X	200/1200	6,0-9,0				
	18	X	200/1200	9,0-12,0				
	22	X	200/1200	12,0-16,0				
	26	X	200/1200	16,0-20,0				
	30	X	150/900	20,0-24,0				
	35	X	100/600	24,0-29,0				
	50	X	500/500	29,0-42,0				

BESTÄLLNINGSEXEMPEL: 11320050160 - KBL-AL/ST 5.0X16

SWEBOLT AB
TEL 08 - 555 975 00 FAX 08 - 583 581 82



ARTIKELLISTA

2013-2014

BLINDNIT KULLRIGT HUVUD NIT ALUMINIUM / SPLINT ALUMINIUM KBL-AL/AL

C:A PRIS/100 ST								
Diameter	Längd	Pris	Förp.	Grepp	Splintdia.	Skalldiam.	Skallhöjd	Borrdiam.
Ø 3.2	6	X	500/4000	1,5-3,5	1,95	6,00	1,00	3,30
	8	X	500/4000	3,5-5,5				
	10	X	500/4000	5,5-7,0				
	12	X	500/4000	7,0-9,0				
	15	X	500/4000	9,0-12,0				
	18	X	500/4000	12,0-15,0				
Ø 4.0	6	X	500/4000	1,5-3,0	2,45	8,00	1,20	4,10
	8	X	500/4000	3,0-4,5				
	10	X	500/4000	4,5-6,5				
	12	X	500/4000	6,5-8,5				
	14	X	500/3000	8,5-10,5				
	16	X	500/3000	10,5-12,5				
	18	X	500/3000	12,5-14,5				
	20	X	500/3000	14,5-16,5				
Ø 4.8	6	X	500/3000	0,5-3,0	2,95	9,00	1,50	4,90
	8	X	500/3000	3,0-4,5				
	10	X	500/3000	4,5-6,0				
	12	X	500/3000	6,0-8,0				
	14	X	500/3000	8,0-12,0				
	16	X	250/2000	10,0-12,0				
	18	X	250/2000	12,0-14,0				
	21	X	250/2000	14,0-17,0				
	24	X	200/1200	17,0-20,0				
	27	X	200/1200	22,0-23,0				

BESTÄLLNINGSEXEMPEL: 11320132060 - KBL-AL/AL 3.2X6



BLINDNIT STORT KULLRIGT HUVUD NIT ALUMINIUM / SPLINT ALUMINIUM SKBL-AL/AL

C:A PRIS/100 ST								
Diameter	Längd	Pris	Förp.	Grepp	Splintdia.	Skalldiam.	Skallhöjd	Borrdiam.
Ø 4.8	10	X	250/2000	4,0-6,0	2,95	14,00	1,80	4,90
	12	X	250/2000	6,0-8,0				
	14	X	250/1500	8,0-10,0				
	16	X	250/1500	10,0-12,0				
	18	X	200/1200	12,0-14,0				
	21	X	200/1200	14,0-17,0				
	24	X	150/900	17,0-20,0				

BESTÄLLNINGSEXEMPEL: 11335148100 - SKBL-AL/AL 4.8X10

ÖVRIGA DIMENSIONER OCH LÄNGDER MOT FÖRFRÅGAN !

SWEBOLT AB

TEL 08 - 555 975 00 FAX 08 - 583 581 82

ARTIKELLISTA

2013-2014

BLINDNIT KULLRIGT HUVUD NIT ALUMINIUM / SPLINT ROSTFRI A2 DIN 7337 KBL-AL/RF



C:A PRIS/100 ST								
Diameter	Längd	Pris	Förp.	Grepp	Splintdia.	Skalldiam.	Skallhöjd	Borrdiam.
Ø 3.2	6	X	500/4000	1,5-3,5	1,8	6,50	0,80	3,30
	8	X	500/4000	3,5-5,5				
	10	X	500/4000	5,5-7,0				
	12	X	500/4000	7,0-9,0				
	15	X	500/4000	9,0-12,0				
	18	X	500/4000	12,0-15,0				
	20		500/4000	15,0-17,0				
Ø 4.0	6	X	500/4000	1,5-3,0	2,20	8,00	1,00	4,10
	8	X	500/4000	3,0-4,5				
	10	X	500/4000	4,5-6,5				
	12	X	500/3000	6,5-8,5				
	14	X	500/3000	8,5-10,5				
	16	X	500/3000	10,5-12,5				
	18	X	500/3000	12,5-14,5				
20	X	500/3000	14,5-16,5					
Ø 4.8	6	X	500/3000	0,5-3,0	2,75	9,50	1,10	4,90
	8	X	500/3000	3,0-4,5				
	10	X	500/3000	4,5-6,0				
	12	X	500/3000	6,0-8,0				
	14	X	250/2000	8,0-10,0				
	16	X	250/2000	10,0-12,0				
	18	X	250/1500	12,0-14,0				
	21	X	250/1500	14,0-17,0				
	24	X	200/1200	17,0-20,0				
	27	X	200/1200	20,0-23,0				
	30	X	200/1200	23,0-25,0				
35	X	150/900	25,0-30,0					
Ø 5.0	10	X	500/3000	4,5-6,0	2,75	9,50	1,10	5,10
	12	X	500/3000	6,0-8,0				
	14	X	250/2000	8,0-10,0				
	16	X	250/2000	10,0-12,0				

BESTÄLLNINGSEXEMPEL: 11320348080 - KRL-AL/RF 4.8X8

BLINDNIT KULLRIGT STORT HUVUD NIT ALUMINIUM / SPLINT ROSTFRI A2 SKBL-AL/RF



Diameter	Längd	Pris	Förp.	Grepp	Splintdia.	Skalldiam.	Skallhöjd	Borrdiam.
Ø 5.0	8	X	250/1500	3,5-4,5	2,75	14,00	1,80	5,10
	10	X	250/1500	4,5-6,0				
	12	X	250/1500	6,0-8,0				
	14	X	250/1500	8,0-10,0				
	16	X	250/1500	10,0-12,0				

BESTÄLLNINGSEXEMPEL: 11335550100 - SKBL-AL/RF 5.0X8

SWEBOLT AB

TEL 08 - 555 975 00 FAX 08 - 583 581 82



ARTIKELLISTA

2013-2014

BLINDNIT KULLRIGT HUVUD NIT STÅL FÖRZINKAD / SPLINT STÅL DACROMET DIN 7337 KBL-ST/ST

C:A PRIS/100 ST								
Diameter	Längd	Pris	Förp.	Grepp	Splintdia.	Skalldiam.	Skallhöjd	Borrdiam.
Ø 3.0	6	X	500/4000	1,5-3,5	2,00	6,50	0,80	3,10
	8	X	500/4000	3,5-5,5				
	10	X	500/4000	5,5-7,0				
	12	X	500/4000	7,0-9,0				
Ø 3.2	6	X	500/4000	1,5-3,5	2,00	6,50	0,80	3,30
	8	X	500/4000	3,5-5,5				
	10	X	500/4000	5,5-7,0				
	12	X	500/4000	7,0-9,0				
	14	X	500/4000	9,0-11,0				
Ø 4.0	6	X	500/4000	1,5-3,0	2,40	8,00	1,00	4,10
	8	X	500/4000	3,0-5,0				
	10	X	500/4000	5,0-6,5				
	12	X	500/3000	6,5-8,5				
	14	X	500/3000	8,5-10,5				
	16	X	500/3000	10,5-12,5				
	18	X	500/3000	12,5-14,5				
	20	X	500/3000	14,5-16,5				
Ø 4.8	6	X	500/3000	0,5-3,0	2,93	9,50	1,10	4,90
	8	X	500/3000	3,0-4,5				
	10	X	500/3000	4,5-6,0				
	12	X	500/3000	6,0-8,0				
	14	X	500/2000	8,0-10,0				
	16	X	250/2000	10,0-12,0				
	18	X	250/1500	12,0-14,0				
	21	X	250/1500	14,0-16,0				
	24	X	200/1200	16,0-19,0				
	30	X	200/1200	20,0-25,0				
	35	X	150/900	25,0-30,0				
Ø 5.0	8	X	500/3000	3,0-4,5	2,93	9,50	1,10	5,10
	10	X	500/3000	4,5-6,0				
	12	X	500/3000	6,0-8,0				
	14	X	250/2000	8,0-10,0				
	16	X	250/2000	10,0-11,5				
	18	X	250/1500	11,5-13,0				
	20	X	250/1500	13,0-15,0				
	25	X	200/1200	15,0-20,0				
	30	X	200/1200	20,0-25,0				
	35	X	150/900	25,0-30,0				
	40	X	150/900	30,0-34,0				
	45	X	100/600	34,0-39,0				
	50	X	100/600	39,0-44,0				
60	X	100/600	44,0-54,0					
Ø 6.0	8	X	250/2000	2,0-4,0	3,6	12,00	1,50	6,10
	10	X	250/1500	4,0-6,0				
	12	X	250/1500	6,0-8,0				
	14	X	250/1500	8,0-10,0				
	16	X	250/1500	10,0-11,0				
	18	X	200/1200	11,0-13,0				
	20	X	200/1200	13,0-15,0				
	25	X	200/1200	15,0-20,0				
	30	X	150/900	20,0-25,0				

BESTÄLLNINGSEXEMPEL: 11320230100 - KBL-ST/ST 3.0X10

SWEBOLT AB

13:5

TEL 08 - 555 975 00 FAX 08 - 583 581 82

ARTIKELLISTA

2013-2014

NIT STÅL FÖRZINKAD / SPLINT STÅL DACROMET DIN 7337 KBL-ST/ST

C:A PRIS/100 ST								
Diameter	Längd	Pris	Förp.	Grepp	Splintdia.	Skalldiam.	Skallhöjd	Borrdiam.
Ø 6.4	8	X	250/1500	1,0-2,0	3,9	13	1,8	6,5
	10	X	250/1500	2,0-4,0				
	12	X	250/1500	4,0-6,0				
	15	X	250/1500	6,0-9,0				
	18	X	200/1200	9,0-12,0				
	20	X	150/900	12,0-14,0				
	22	X	150/900	14,0-16,0				
	25	X	150/900	16,0-19,0				
30	X	100/600	19,0-24,0					

BESTÄLLNINGSEXEMPEL: 11320264100 - KBL-ST/ST 6.4X10

NIT ROSTFRI A2 / SPLINT ROSTFRI A2 KBL-RF/RF

C:A PRIS/100 ST								
Diameter	Längd	Pris	Förp.	Grepp	Splintdia.	Skalldiam.	Skallhöjd	Borrdiam.
Ø 3.0	6	X	500/4000	1,0-3,0	2,00	6,50	0,80	3,10
	8	X	500/4000	3,0-5,0				
	10	X	500/4000	5,0-7,0				
	12	X	500/4000	7,0-9,0				
Ø 3.2	6	X	500/4000	1,0-3,0	2,00	6,50	0,80	3,30
	8	X	500/4000	3,0-5,0				
	10	X	500/4000	5,0-7,0				
	12	X	500/4000	6,0-9,0				
	15	X	500/4000	9,0-12,0				
	18	X	500/4000	12,0-15,0				
Ø 4.0	6	X	500/4000	1,0-3,0	2,50	8,00	1,00	4,10
	8	X	500/4000	2,5-4,5				
	10	X	500/4000	4,5-6,5				
	12	X	500/3000	6,5-8,5				
	14	X	500/3000	8,5-10,9				
	16	X	500/3000	10,5-12,0				
	18	X	500/3000	12,0-14,0				
	20	X	500/3000	14,0-16,0				
Ø 4.8	8	X	500/3000	1,0-3,0	3,10	9,50	1,10	4,90
	10	X	500/3000	4,0-6,0				
	12	X	500/3000	6,0-8,0				
	14	X	500/2000	8,0-10,0				
	16	X	250/2000	10,0-12,0				
Ø 4.8	18	X	250/1500	12,0-14,0	2,90	9,50	1,10	4,90
	20	X	250/1500	14,0-16,0				
	25	X	200/1200	16,0-20,0				
	30	X	200/1200	20,0-25,0				
Ø 5.0	8	X	500/3000	1,0-3,0	3,10	9,50	1,10	5,10
	10	X	500/3000	4,0-6,0				
	12	X	500/3000	6,0-8,0				
	14	X	250/2000	8,0-10,0				
	16	X	250/2000	10,0-12,0				
Ø 6.4	12	X	250/1500	2,0-6,0	3,60	13,80	1,10	6,50
	15	X	250/1500	6,0-9,0				
	18	X	250/1500	9,0-12,0				

BESTÄLLNINGSEXEMPEL: 11320432060 - KBL-RF/RF 3.2X6

SWEBOLT AB

TEL 08 - 555 975 00 FAX 08 - 583 581 82



ARTIKELLISTA

2013-2014

BLINDNIT STORT KULLRIGT HUVUD NIT ALUMINIUM / SPLINT STÅL FÖRZINKAD SKBL-AL/ST

C:A PRIS/100 ST								
Diameter	Längd	Pris	Förp.	Grepp	Splintdia.	Skalldiam.	Skallhöjd	Borrdiam.
Ø 3.2 D=9,5mm	6	X	500/4000	0,5-3,5	1,80	9,50	1,10	3,30
	8	X	500/4000	3,5-5,5				
	10	X	500/4000	5,5-7,0				
	12	X	500/4000	7,0-9,0				
	14	X	500/4000	8,0-10,0				
	16	X	500/4000	9,0-11,0				
Ø 4.0 D=12mm	8	X	500/3000	1,5-5,0	2,20	12,00	1,40	4,10
	10	X	500/3000	5,0-6,5				
	12	X	250/2000	6,5-8,5				
	14	X	250/2000	8,5-10,5				
	16	X	250/2000	10,5-12,5				
	18	X	250/2000	12,5-14,5				
	20	X	250/2000	14,5-16,5				
Ø 4.8 D=14mm	10	X	250/1500	3,0-6,0	2,75	14,00	1,80	4,90
	12	X	250/1500	6,0-8,0				
	14	X	250/1500	8,0-10,0				
	16	X	250/1500	10,0-12,0				
	18	X	200/1200	12,0-14,0				
	21	X	200/1200	14,0-17,0				
	24	X	150/900	17,0-20,0				
	27	X	150/900	20,0-23,0				
	30	X	150/900	23,0-25,0				
	35	X	100/600	25,0-30,0				
	40	X	100/600	30,0-35,0				
	45	X	100/600	35,0-40,0				
50	X	100/600	40,0-45,0					
Ø 4.8 D=16mm	10	X	250/1500	3,0-6,0	2,75	16,00	1,80	4,90
	12	X	250/1500	6,0-8,0				
	14	X	250/1500	8,0-10,0				
	16	X	200/1200	10,0-12,0				
	18	X	200/1200	12,0-14,0				
	21	X	150/900	14,0-17,0				
	24	X	150/900	17,0-20,0				
	27	X	150/900	20,0-23,0				
	30	X	150/900	23,0-25,0				
	35	X	100/600	25,0-30,0				
Ø 5.0 D=11mm	8	X	250/2000	3,0-4,5	2,75	11,00	1,60	5,10
	10	X	250/2000	4,5-6,0				
	12	X	250/2000	6,0-8,0				
	14	X	250/1500	8,0-10,0				
	16	X	250/1500	10,0-12,0				
	18	X	250/1500	12,0-14,0				
	20	X	250/1500	14,0-16,0				
	25	X	250/1500	16,0-21,0				
30	X	200/1200	21,0-25,0					
Ø 5.0 D=14mm	8	X	250/1500	3,0-4,5	2,75	14,00	1,80	5,10
	10	X	250/1500	4,5-6,0				
	12	X	250/1500	6,0-8,0				
	14	X	250/1500	8,0-10,0				
	16	X	250/1500	10,0-12,0				
	18	X	200/1200	12,0-14,0				
	20	X	200/1200	14,0-16,0				
	25	X	150/900	16,0-21,0				
	30	X	150/900	21,0-25,0				

BESTÄLLNINGSEXEMPEL: 11335032120 - SKBL-AL/ST 3.2X12

SWEBOLT AB



ARTIKELLISTA
2013-2014
BLINDNIT KULLRIGT HUVUD
DIN 7337
KBL-A4/A4

C:A PRIS/100 ST								
Diameter	Längd	Pris	Förp.	Grepp	Splintdia.	Skalldiam.	Skallhöjd	Borrdiam.
Ø 3.2	6	X	500/4000	1,0-3,0	2,10	6,20	1,00	3,30
	8	X	500/4000	3,0-5,0				
	10	X	500/4000	5,0-7,0				
	12	X	500/4000	7,0-9,0				
Ø 4.0	6	X	500/4000	1,0-3,0	2,40	8,00	1,30	4,10
	8	X	500/4000	3,0-5,0				
	10	X	500/4000	5,0-7,0				
	12	X	500/3000	7,0-9,0				
	14	X	500/3000	9,0-11,0				
Ø 4.8	8	X	500/3000	1,0-3,0	3,10	8,70	1,40	4,90
	10	X	500/3000	4,0-6,0				
	12	X	500/3000	6,0-8,0				
	14	X	250/2000	8,0-10,0				

ÖVRIGA DIMENSIONER OCH LÄNGDER MOT FÖRFRÅGAN !

BESTÄLLNINGSEXEMPEL: 11320740100 - KBL-A4/A4 4.0X10

SWEBOLT AB
TEL 08 - 555 975 00 FAX 08 - 583 581 82



ARTIKELLISTA

2013-2014

BLINDNIT FÖRSÄNKT HUVUD 120° NIT ALUMINIUM / SPLINT STÅL FÖRZINKAD DIN 7337 FBL-AL/ST

C:A PRIS/100 ST								
Diameter	Längd	Pris	Förp.	Grepp	Splintdia.	Skalldiam.	Skallhöjd	Borrdiam.
Ø 3.0	6	X	500/4000	1,5-3,5	1,80	6,00	0,90	3,10
	8	X	500/4000	3,5-5,5				
	10	X	500/4000	5,5-7,0				
	12	X	500/4000	7,0-9,0				
	14	X	500/4000	9,0-11,0				
	16	X	500/4000	11,0-13,0				
Ø 3.2	6	X	500/4000	1,5-3,5	1,80	6,00	0,90	3,30
	8	X	500/4000	3,5-5,5				
	10	X	500/4000	5,5-7,0				
	12	X	500/4000	7,0-9,0				
	15	X	500/4000	9,0-11,0				
	18	X	500/4000	11,0-13,0				
Ø 4.0	6	X	500/4000	1,5-3,0	2,20	7,50	1,00	4,10
	8	X	500/4000	3,0-5,0				
	10	X	500/4000	5,0-6,5				
	12	X	500/3000	6,5-8,5				
	14	X	500/3000	8,5-10,5				
	16	X	500/3000	10,5-12,5				
	18	X	500/3000	12,5-14,5				
	20	X	500/3000	14,5-16,5				
Ø 4.8	6	X	500/3000	0,5-3,0	2,75	9,00	1,20	4,90
	8	X	500/3000	3,0-4,5				
	10	X	500/3000	4,5-6,0				
	12	X	500/3000	6,0-8,0				
	14	X	500/2000	8,0-10,0				
	16	X	250/2000	10,0-12,0				
	18	X	250/1500	12,0-14,0				
	21	X	250/1500	14,0-17,0				
	24	X	200/1200	17,0-20,0				
	27	X	200/1200	20,0-23,0				
	30	X	200/1200	23,0-25,0				
	35	X	150/900	25,0-30,0				
Ø 5.0	6	X	500/3000	0,5-3,0	2,75	9,00	1,20	5,10
	8	X	500/3000	3,0-4,5				
	10	X	500/3000	4,5-6,0				
	12	X	500/3000	6,0-8,0				
	14	X	500/2000	8,0-10,0				
	16	X	500/2000	10,0-12,0				
	18	X	250/1500	12,0-14,0				
	20	X	250/1500	14,0-16,0				
	25	X	200/1200	16,0-21,0				
	30	X	200/1200	21,0-25,0				

ÖVRIGA DIMENSIONER OCH LÄNGDER MOT FÖRFRÅGAN !

BESTÄLLNINGSEXEMPEL: 11350032100 - FBL-AL/ST 3.2X10

SWEBOLT AB

TEL 08 - 555 975 00 FAX 08 - 583 581 82

13:15

ARTIKELLISTA

2013-2014

**BLINDNIT FÖRSÄNKT HUVUD 120°
NIT STÅL FÖRZINKAD / SPLINT STÅL DACROMET
DIN 7337
FBL-ST/ST**



C:A PRIS/100 ST								
Diameter	Längd	Pris	Förp.	Grepp	Splintdia.	Skalldiam.	Skallhöjd	Borrdiam.
Ø 4.0	8	X	500/4000	3,0-5,0	2,20	7,50	1,00	4,10
	10	X	500/4000	5,0-6,5				
	12	X	500/4000	6,8-8,5				
	14	X	500/3000	8,5-10,5				
Ø 4.8	8	X	500/3000	3,0-4,5	2,75	9,00	1,20	4,90
	10	X	500/3000	4,5-6,0				
	12	X	500/3000	6,0-8,0				
	14	X	250/2000	8,0-10,0				

ÖVRIGA DIMENSIONER OCH LÄNGDER MOT FÖRFRÅGAN !

BESTÄLLNINGSEXEMPEL: 11350140080 - FBL-ST/ST 4.0X8

SWEBOLT AB

TEL 08 - 555 975 00 FAX 08 - 583 581 82

13:16



ARTIKELLISTA
2013-2014
BLINDNIT KULLRIGT HUVUD
NIT KOPPAR / SPLINT STÅL FÖRZINKAD
KBL-KO/ST

C:A PRIS/100 ST								
Diameter	Längd	Pris	Förp.	Grepp	Splintdia.	Skalldiam.	Skallhöjd	Borrdiam.
Ø 3.0	6	X	500/4000	1,5-3,5	2,00	6,50	0,80	3,10
	8	X	500/4000	3,5-5,5				
	10	X	500/4000	5,5-7,0				
	12	X	500/4000	7,0-9,0				
Ø 4.0	6	X	500/4000	1,5-3,0	2,40	8,00	1,00	4,10
	8	X	500/4000	3,0-5,0				
	10	X	500/4000	5,0-6,5				
	12	X	500/3000	6,5-8,5				
	14	X	500/3000	8,5-10,5				
	16	X	500/3000	10,5-12,5				
Ø 4.8	8	X	500/3000	3,0-4,5	2,93	9,50	1,10	4,90
	10	X	500/3000	4,5-6,0				
	12	X	500/3000	6,0-8,0				
	14	X	250/2000	8,0-10,0				

ÖVRIGA DIMENSIONER OCH LÄNGDER MOT FÖRFRÅGAN !

BESTÄLLNINGSEXEMPEL: 11320530120 - KBL-KO/ST 3.0X12

SWEBOLT AB

TEL 08 - 555 975 00 FAX 08 - 583 581 82

13:17

ARTIKELLISTA
2013-2014
BLINDNIT KULLRIGT HUVUD
NIT KOPPAR / SPLINT BRONS
KBL-KO/BR



C:A PRIS/100 ST								
Diameter	Längd	Pris	Förp.	Grepp	Splintdia.	Skalldiam.	Skallhöjd	Borrdiam.
Ø 3.0	6	X	500/4000	1,5-3,5	1,80	6,50	0,80	3,10
	8	X	500/4000	3,5-5,5				
	10	X	500/4000	5,5-7,0				
	12	X	500/4000	7,0-9,0				
Ø 3.2	6	X	500/4000	1,5-3,5	2,00	6,50	0,80	3,30
	8	X	500/4000	3,5-5,5				
	10	X	500/4000	5,5-7,0				
	12	X	500/4000	7,0-9,0				
Ø 4.0	6	X	500/4000	1,5-3,0	2,40	8,00	1,00	4,10
	8	X	500/4000	3,0-5,0				
	10	X	500/4000	5,0-6,5				
	12	X	500/3000	6,5-8,5				
	14	X	500/3000	8,5-10,5				
	16	X	500/3000	10,5-12,5				

ÖVRIGA DIMENSIONER OCH LÄNGDER MOT FRÖFRÅGAN !

BESTÄLLNINGSEXEMPEL: 11320630100 - KBL-KO/BR 3.0X10

SWEBOLT AB
TEL 08 - 555 975 00 FAX 08 - 583 581 82



ARTIKELLISTA
2013-2014
BLINDNIT FÖRSÄNKT HUVUD
ROSTFRI / ROSTFRI
FBL-RF/RF

C:A PRIS/100 ST								
Diameter	Längd	Pris	Förp.	Grepp	Splintdia.	Skalldiam.	Skallhöjd	Borrdiam.
Ø 3.2	6	X	500/4000	1,5-3,5	2,10	6,00	0,90	3,30
	8	X	500/4000	3,5-5,5				
	10	X	500/4000	5,5-7,0				
	12	X	500/4000	7,0-9,0				
Ø 4.0	8	X	500/4000	3,0-5,0	2,40	7,50	1,00	4,10
	10	X	500/4000	5,0-6,5				
	12	X	500/3000	6,5-8,5				
	14	X	500/3000	8,5-10,5				
Ø 4.8	8	X	500/3000	3,0-4,5	3,10	9,00	1,20	4,90
	10	X	500/3000	4,5-6,0				
	12	X	500/3000	6,0-8,0				
	14	X	250/2000	8,0-10,0				

ÖVRIGA DIMENSIONER OCH LÄNGDER MOT FÖRFRÅGAN !

BESTÄLLNINGSEXEMPEL: 11350440100 - FBL-RF/RF 4,0X10

SWEBOLT AB

TEL 08 - 555 975 00 FAX 08 - 583 581 82+

ARTIKELLISTA
2013-2014
BLINDNIT STORT KULLRIGT HUVUD
NIT STÅL FÖRZINKAD / SPLINT STÅL DACROMET
SKBL-ST/ST



C:A PRIS/100 ST								
Diameter	Längd	Pris	Förp.	Grepp	Splintdia.	Skalldiam.	Skallhöjd	Borrdiam.
Ø 4.0 D=12mm	6	X	500/3000	1,5-3,0	2,40	12,00	1,40	4,10
	8	X	500/3000	3,0-5,0				
	10	X	500/3000	5,0-6,5				
	12	X	250/2000	6,5-8,5				
	14	X	250/1500	8,5-10,5				
Ø 4.8 D=14mm	10	X	250/2000	3,0-6,0	2,93	14,00	1,80	4,90
	12	X	250/2000	6,0-8,0				
	14	X	250/1500	8,0-10,0				
	16	X	250/1500	10,0-12,0				
	18	X	250/1200	12,0-14,0				
	21	X	200/1200	14,0-16,0				
	24	X	150/600	16,0-18,0				
	30	X	150/600	18,0-20,0				

ÖVRIGA DIMENSIONER OCH LÄNGDER MOT FÖRFRÅGAN !

BESTÄLLNINGSEXEMPEL: 11335248100 - SKBL-ST/ST 4,8X10

ARTIKELLISTA

2013-2014

TRYCKTÄT BLINDNIT KULLRIGT HUVUD NIT ALUMINIUM / SPLINT STÅL FÖRZINKAD TKBL-AL/ST



C:A PRIS/100 ST								
Diameter	Längd	Pris	Förp.	Grepp	Splintdia.	Skalldiam.	Skallhöjd	Borrdiam.
Ø 3.2	6,5	X	500/4000	0,5-2,0	1,70	6,00	0,90	3,30
	8	X	500/4000	2,0-3,5				
	9,5	X	500/4000	3,5-5,0				
	11	X	500/4000	5,0-6,5				
	12,5	X	500/4000	6,5-8,0				
Ø 4.0	8	X	500/4000	0,5-3,5	2,20	8,00	1,30	4,10
	9,5	X	500/4000	3,5-5,0				
	11	X	500/4000	5,0-6,5				
	12,5	X	500/3000	6,5-8,0				
	14,5	X	500/3000	8,0-10,0				
Ø 4.8	8,5	X	500/3000	0,5-3,5	2,60	9,50	1,50	4,90
	9,5	X	500/3000	3,5-5,0				
	11	X	500/3000	5,0-6,5				
	13	X	250/2000	6,5-8,0				
	14,5	X	250/2000	8,0-9,5				
	16	X	250/2000	9,5-11,5				
	18	X	250/1500	11,5-13,0				
	21	X	250/1500	13,0-16,0				
25	X	200/1200	16,0-20,0					
Ø 6.4	12,7	X	250/1500	4,0-7,0	3,60	12,50	1,80	6,50
	15,5	X	200/1200	7,0-10,0				

BESTÄLLNINGSEXEMPEL: 11329048095 - TKBL-AL/ST 4.8X9.5

TRYCKTÄT BLINDNIT STORT KULLRIGT HUVUD NIT ALUMINIUM / SPLINT STÅL FÖRZINKAD STKBL-AL/ST



C:A PRIS/100 ST								
Diameter	Längd	Pris	Förp.	Grepp	Splintdia.	Skalldiam.	Skallhöjd	Borrdiam.
Ø 4.8	13	X	250/1500	6,5-8,0	2,75	14,00	1,80	4,90
	18	X	200/1200	10,5-12,5				

ÖVRIGA DIMENSIONER OCH LÄNGDER MOT FÖRFRÅGAN !

BESTÄLLNINGSEXEMPEL: 11331048130 - STKBL-AL/ST 4.8X13

SWEBOLT AB

TEL 08 - 555 975 00 FAX 08 - 583 581 82



ARTIKELLISTA
2013-2014
BLINDNIT FÖRSÄNKT HUVUD TRYCKTÄT
ALUMINIUM / ALUMINIUM
TKBL-AL/AL

C:A PRIS/100 ST								
Diameter	Längd	Pris	Förp.	Grepp	Splintdia.	Skalldiam.	Skallhöjd	Borrdiam.
Ø 3.2	8	X	500/4000	0,5-2,0	1,80	6,35	1,40	3,30
	9,5	X	500/4000	2,0-5,0				
Ø 4.0	9,5	X	500/4000	3,5-5,0	2,20	8,00	1,70	4,10
	12,5	X	500/3000	5,0-8,0				
Ø 4.8	9,5	X	500/3000	3,5-5,0	2,65	9,50	2,00	4,90
	11,5	X	500/3000	5,0-6,5				
	12,5	X	250/2000	6,0-7,5				
	14,5	X	250/2000	6,5-9,5				
	18	X	250/1500	9,5-13,0				

ÖVRIGA DIMENSIONER OCH LÄNGDER MOT FÖRFRÅGAN !

BESTÄLLNINGSEXEMPEL: 11329140125 - TKBL-AL/AL 4,0X12,5

SWEBOLT AB

TEL 08 - 555 975 00 FAX 08 - 583 581 82

13:27

ARTIKELLISTA

2013-2014

TRYCKTÄT BLINDNIT KULLRIGT HUVUD NIT ALUMINIUM / SPLINT ROSTFRI A2 TKBL-AL/RF



C:A PRIS/100 ST								
Diameter	Längd	Pris	Förp.	Grepp	Splintdia.	Skalldiam.	Skallhöjd	Borrdiam.
Ø 3.2	6,5	X	500/4000	0,5-2,0	1,70	6,00	0,80	3,30
	8	X	500/4000	2,0-3,5				
	9,5	X	500/4000	3,5-5,0				
	12,5	X	500/4000	6,5-8,0				
Ø 4.0	8	X	500/4000	0,5-3,5	2,20	8,00	1,30	4,10
	9,5	X	500/4000	3,5-5,0				
	11	X	500/4000	5,0-6,5				
	12,5	X	500/3000	6,5-8,0				
Ø 4.8	8	X	500/3000	0,5-3,5	2,65	9,50	1,50	4,90
	9,5	X	500/3000	3,5-5,0				
	11	X	500/3000	5,0-6,5				
	13	X	250/2000	6,5-8,0				
	14,5	X	250/2000	8,0-9,5				
	16	X	250/2000	9,5-11,0				
	18	X	250/1500	11,0-13,0				
21	X	250/1500	13,0-16,0					

BESTÄLLNINGSEXEMPEL: 11329240110 - TKBL-AL/RF 4.0X11

ÖVRIGA DIMENSIONER OCH LÄNGDER MOT FÖRFRÅGAN !

SWEBOLT AB

TEL 08 - 555 975 00 FAX 08 - 583 581 82

13:28



ARTIKELLISTA
2013-2014
BLINDNIT FÖRSÄNKT HUVUD TRYCKTÄT
KOPPAR / STÅL
TKBL-KO/ST

C:A PRIS/100 ST								
Diameter	Längd	Pris	Förp.	Grepp	Splintdia.	Skalldiam.	Skallhöjd	Borrdiam.
Ø 3.2	9,5	X	500/4000	3,5-5,5	1,70	6,35	1,40	3,30
Ø 4.0	10	X	500/4000	3,5-5,5	2,20	8,00	1,40	4,10
Ø 4.8	9,5	X	500/3000	2,5-4,5	2,65	9,50	1,60	4,90
	12	X	500/3000	4,5-6,5				

ÖVRIGA DIMENSIONER OCH LÄNGDER MOT FÖRFRÅGAN !

BESTÄLLNINGSEXEMPEL: 11329340100 - TKBL-KO/ST 4,0X10

SWEBOLT AB

TEL 08 - 555 975 00 FAX 08 - 583 581 82

13:29

ARTIKELLISTA

2013-2014

TRYCKTÄT BLINDNIT KULLRIGT HUVUD NIT STÅL FÖRZINKAD / SPLINT STÅL DACROMET TKBL-ST/ST



C:A PRIS/100 ST								
Diameter	Längd	Pris	Förp.	Grepp	Splintdia.	Skalldiam.	Skallhöjd	Borrdiam.
Ø 3.2	8	X	500/4000	0,5-3,0	1,90	6,00	1,00	3,30
	9,5	X	500/4000	1,0-4,5				
	12	X	500/4000	4,0-7,0				
Ø 4.0	8	X	500/4000	0,5-3,5	2,30	8,00	1,40	4,10
	10	X	500/4000	1,0-5,0				
	12	X	500/3000	5,0-7,5				
	15	X	500/3000	7,5-10,5				
Ø 4.8	9,5	X	500/3000	1,0-4,0	2,90	9,50	1,70	4,90
	12	X	500/3000	4,0-6,0				

ÖVRIGA DIMENSIONER OCH LÄNGDER MOT FÖRFRÅGAN !

BESTÄLLNINGSEXEMPEL: 11329432120 - TKBL-ST/ST 3.2X12

SWEBOLT AB

TEL 08 - 555 975 00 FAX 08 - 583 581 82

13:30



ARTIKELLISTA

2013-2014

BLINDNIT STORT KULLRIGT HUVUD TRYCKTÄT ROSTFRI / ROSTFRI TKBL-RF/RF

C:A PRIS/100 ST								
Diameter	Längd	Pris	Förp.	Grepp	Splintdia.	Skalldiam.	Skallhöjd	Borrdiam.
Ø 3.2	8	X	500/4000	0,5-3,0	1,90	6,00	1,00	3,30
	9,5	X	500/4000	1,0-4,5				
	12	X	500/4000	4,5-7,0				
Ø 4.0	8	X	500/4000	0,5-3,0	2,30	8,00	1,40	4,10
	9,5	X	500/4000	1,0-4,5				
	12	X	500/3000	4,5-7,5				
	14	X	500/3000	7,0-10,0				
	16	X	500/3000					
Ø 4.8	9,5	X	500/3000	1,0-4,0	2,90	9,50	1,40	4,90
	12	X	500/3000	4,0-6,0				
	13	X	250/2000	5,0-7,0				
	15	X	250/2000	5,0-9,0				
	16	X	250/2000	6,0-10,0				
	17	X	250/1500	10,0-12,0				
	18	X	250/1500	11,0-13,0				

ÖVRIGA DIMENSIONER MOT FÖRFRÅGAN !

BESTÄLLNINGSEXEMPEL: 11329540120 - TKBL-RF/RF 4,0X12

SWEBOLT AB

TEL 08 - 555 975 00 FAX 08 - 583 581 82

13:31

ARTIKELLISTA

2013-2014

BLINDNIT KULLRIGT HUVUD EXTRA LÅNG NIT ALUMINIUM / SPLINT STÅL FÖRZINKAD KBLEL-AL/ST



C:A PRIS/100 ST								
Diameter	Längd	Pris	Förp.	Grepp	Splintdia.	Skalldiam.	Skallhöjd	Borrdiam.
Ø 4.0	35	X	250/1500	26,0-31,5	2,10	7,50	1,00	4,10
	40	X	250/1500	31,5-36,5				
Ø 5.0	40	X	150/900	30,0-35,0	2,73	9,30	1,50	5,10
	45	X	100/600	35,0-40,0				
	50	X	100/600	40,0-45,0				
	55	X	100/600	45,0-48,0				
	60	X	100/600	48,0-52,0				
	65	X	100/600	52,0-57,0				
	70	X	100/600	57,0-62,0				
	75	X	100/600	62,0-67,0				
	80	X	100/600	67,0-72,0				
	90	X	100/600	72,0-82,0				
	100	X	1000	82,0-92,0				
	110	X	500	92,0-102,0				
	120	X		102,0-112,0				
	130	X		112,0-122,0				
	140	X		122,0-132,0				
	150	X		132,0-142,0				
	160	X		142,0-152,0				
170	X		152,0-162,0					
180	X		162,0-172,0					
190	X		172,0-182,0					
Ø 6.4	80	X	500	42,0-73,0	3,60	13,00	2,00	6,50
	100	X	500	73,0-93,0				
	120	X	500	93,0-113,0				
	150	X		113,0-143,0				
	175	X		143,0-168,0				
	200	X		168,0-193,0				

ÖVRIGA DIMENSIONER OCH LÄNGDER MOT FÖRFRÅGAN !

BESTÄLLNINGSEXEMPEL: 11324050050 - KBLEL-AL/ST 5.0X50

BESTÄLLNINGSEXEMPEL: 11324050150 - KBLEL-AL/ST 5.0X150

SWEBOLT AB

TEL 08 - 555 975 00 FAX 08 - 583 581 82

13:34

ARTIKELLISTA

2013-2014

BLINDNIT KULLRIGT HUVUD MULTIGRIP NIT ALUMINIUM / SPLINT STÅL DACROMET KBLMG-AL/ST



C:A PRIS/100 ST								
Diameter	Längd	Pris	Förp.	Grepp	Splintdia.	Skalldiam.	Skallhöjd	Borrdiam.
Ø 3.2	8	X	500/4000	0,5-5,0	1,80	6,20	1,10	3,3-3,5
	11	X	500/4000	4,0-8,0				
Ø 4.0	6,5	X	500/4000	0,5-4,0	2,20	8,20	1,40	4,1-4,3
	9,5	X	500/4000	1,0-6,0				
	12,5	X	500/3000	4,0-9,0				
	16,5	X	500/3000	6,0-13,0				
Ø 4.8	10,5	X	250/2000	1,5-6,5	2,75	9,20	1,80	4,9-5,1
	15	X	250/2000	4,5-11,0				
	16,5	X	250/1500	6,5-13,0				
	19,5	X	250/1500	8,5-16,0				
	24,5	X	200/1200	12,5-20,0				

BESTÄLLNINGSEXEMPEL: 11338540095 - KBLMG-AL/ST 4.0X9.5

BLINDNIT KULLRIGT STORT HUVUD MULTIGRIP NIT ALUMINIUM / SPLINT STÅL DACROMET SKBLMG-AL/ST



C:A PRIS/100 ST								
Diameter	Längd	Pris	Förp.	Grepp	Splintdia.	Skalldiam.	Skallhöjd	Borrdiam.
Ø 4.0	13	X	250/2000	3,0-9,0	2,20	12,00	1,40	4,1-4,3
	16,5	X	250/2000	6,0-13,0				
Ø 4.8	10,5	X	200/1200	1,5-6,0	2,75	16,00	1,80	4,9-5,1
	17	X	150/900	6,5-12,5				
	25	X	150/900	12,0-19,5				

BESTÄLLNINGSEXEMPEL: 11339048170 - SKBLMG-AL/ST 4.8X17

BLINDNIT KULLRIGT HUVUD MULTIGRIP NIT ALUMINIUM / SPLINT ROSTFRI A2 KBLMG-AL/RF



C:A PRIS/100 ST								
Diameter	Längd	Pris	Förp.	Grepp	Splintdia.	Skalldiam.	Skallhöjd	Borrdiam.
Ø 3.2	8	X	500/4000	0,5-5,0	1,80	6,20	1,10	3,3-3,5
	11	X	500/4000	4,0-8,0				
Ø 4.0	6,5	X	500/4000	1,0-3,0	2,2	8,2	1,4	4,1-4,3
	9,5	X	500/4000	3,0-6,0				
	12,5	X	500/3000	6,0-9,0				
	16,5	X	500/3000	9,0-13,0				
Ø 4.8	10,5	X	250/2000	1,5-6,5	2,75	9,2	1,8	4,9-5,1
	15	X	250/2000	4,5-11,0				
	16,5	X	250/1500	6,5-13,0				
	24,5	X	200/1200	12,5-20,0				

BESTÄLLNINGSEXEMPEL: 11338640095 - KBLMG-AL/RF 4.0X9.5

SWEBOLT AB

TEL 08 - 555 975 00 FAX 08 - 583 581 82

ARTIKELLISTA

2013-2014

BLINDNIT KULLRIGT HUVUD FÖR MJUKA MATERIAL NIT ALUMINIUM / SPLINT STÅL FÖRZINKAD KBLSM-AL/ST



C:A PRIS/100 ST								
Diameter	Längd	Pris	Förp.	Grepp	Splintdia.	Skalldiam.	Skallhöjd	Borrdiam.
Ø 4.0	6	X	7000	1,5-3,0	2,20	8,00	1,00	4,10
	8	X	7000	3,0-4,5				
	10	X	7000	4,5-6,5				
	12	X	5000	6,5-8,5				
	14	X	5000	8,5-10,5				
	16	X	5000	10,5-12,5				
	18	X	5000	12,5-14,5				
	20	X	5000	14,5-16,5				
Ø 4.8	6	X	5000	0,5-3,0	2,75	9,50	1,10	4,10
	8	X	4000	3,0-4,5				
	10	X	4000	4,5-6,0				
	12	X	4000	6,0-8,00				
	14	X	3000	8,0-10,0				
	16	X	3000	10,0-12,0				
	18	X	3000	12,0-14,0				
	21	X	3000	14,0-17,0				
	24	X	2000	17,0-20,0				
	27	X	2000	20,0-23,0				
	30	X	2000	23,0-25,0				

ÖVRIGA DIMENSIONER OCH LÄNGDER MOT FÖRFRÅGAN !

BESTÄLLNINGSEXEMPEL: 11333048140 - KBLSM-AL/ST 4,8X14

SWEBOLT AB

TEL 08 - 555 975 00 FAX 08 - 583 581 82

13:42



ARTIKELLISTA

2013-2014

STORT KULLRIGT HUVUD FÖR MJUKA MATERIAL NIT ALUMINIUM / SPLINT STÅL FÖRZINKAD SKBLSM-AL/ST

C:A PRIS/100 ST								
Diameter	Längd	Pris	Förp.	Grepp	Splintdia.	Skalldiam.	Skallhöjd	Borrdiam.
Ø 4.0 D=12mm	8	X	500/3000	4,00	2,20	12,00	1,40	4,20
	10	X	500/3000	6,00				
	12	X	250/2000	8,00				
	14	X	250/2000	10,00				
	16	X	250/2000	12,00				
	18	X	250/2000	14,00				
	20	X	250/2000	16,00				
Ø 4.8 D=14mm	10	X	250/2000	5,00	2,75	14,00	1,80	5,00
	12	X	250/2000	7,00				
	14	X	250/1500	9,00				
	16	X	250/1500	11,00				
	18	X	200/1200	13,00				
	21	X	200/1200	16,00				
	24	X	150/900	19,00				
	27	X	150/900	22,00				
	30	X	150/900	25,00				
	35	X	100/800	30,00				

ÖVRIGA DIMENSIONER OCH LÅNGDER MOT FÖRFRÅGAN !

BESTÄLLNINGSEXEMPEL: 113331040100 - SKBLSM-AL/ST 4.0X10

SWEBOLT AB

TEL 08 - 555 975 00 FAX 08 - 583 581 82



ARTIKELLISTA

2013-2014

BLINDNIT SPLITNIT EXTRA LÅNG KULLRIGT HUVUD NIT ALUMINIUM / SPLINT STÅL FÖRZINKAD KBLSMEL-AL/ST

C:A PRIS/100 ST								
Diameter	Längd	Pris	Förp.	Grepp	Splintdia.	Skalldiam.	Skallhöjd	Borrdiam.
Ø 3.2	8	X	500/4000	3,50	1,80	6,50	0,8	3,40
	10	X	500/4000	5,00				
	12	X	500/4000	7,00				
	14	X	500/4000	9,00				
	16	X	500/4000	11,00				
	18	X	500/4000	13,00				
Ø 4.0	8	X	500/4000	4,00	2,20	8,00	1,00	4,20
	10	X	500/4000	6,00				
	12	X	500/3000	8,00				
	14	X	500/3000	10,00				
	16	X	500/3000	12,00				
	18	X	500/3000	14,00				
	20	X	500/3000	16,00				
	25	X	250/1500	21,00				
Ø 4.8	10	X	500/3000	5,00	2,75	9,50	1,10	5,00
	12	X	500/3000	7,00				
	14	X	250/2000	9,00				
	16	X	250/2000	11,00				
	18	X	250/1500	13,00				
	21	X	250/1500	16,00				
	24	X	200/1200	19,00				
	27	X	200/1200	22,00				
	30	X	200/1200	25,00				
	32	X	150/900	27,00				
	35	X	150/900	30,00				
	40	X	150/900	32,00				
	45	X	100/600	37,00				
	50	X	100/600	42,00				

ÖVRIGA DIMENSIONER OCH LÄNGDER MOT FÖRFRÅGAN !

BESTÄLLNINGSEXEMPEL: 11333248016 - KBLSMEL-AL/ST 4.8X16

SWEBOLT AB

TEL 08 - 555 975 00 FAX 08 - 583 581 82

13:45

ARTIKELLISTA

2013-2014

BLINDNIT SPLITNIT EXTRA LÅNG KULLRIGT HUVUD NIT ALUMINIUM / SPLINT STÅL FÖRZINKAD KBLSMEL-AL/ST



C:A PRIS/100 ST								
Diameter	Längd	Pris	Förp.	Grepp	Splintdia.	Skalldiam.	Skallhöjd	Borrdiam.
Ø 5.0	40	X	150/900	32,00	2,75	9,30	1,50	5,20
	45	X	100/600	37,00				
	50	X	100/600	42,00				
	55	X	100/600	47,00				
	60	X	100/600	52,00				
	65	X	100/600	57,00				
	70	X	100/600	62,00				
	75	X	100/600	68,00				
	80	X	100/600	72,00				
	90	X	100/600	80,00				
	100	X	1000	90,00				
	110	X	500	100,0				
	120	X		110,0				
	130	X		120,0				
	140	X		130,0				
	150	X		140,0				
	160	X		150,0				
170	X		160,0					
180	X		170,0					
190	X		180,0					
Ø 6.4	35	X	1000	25,00	3,60	13,00	2,00	6,60
	50	X	750	40,00				
	80	X	500	70,00				
	100	X		90,00				
	120	X		110,0				
	150	X		140,0				
	175	X		165,0				
200	X		190,0					

ÖVRIGA DIMENSIONER OCH LÅNGDER MOT FÖRFRÅGAN !

BESTÄLLNINGSEXEMPEL: 11333250040 - KBLSMEL-AL/ST 5.0X40

SWEBOLT AB

TEL 08 - 555 975 00 FAX 08 - 583 581 82

13:46



ARTIKELLISTA

2013-2014

BLINDNIT KULLRIGT HUVUD BOTTENHÅL NIT ALUMINIUM / SPLINT STÅL FÖRZINKAD KBLBH-AL/ST

C:A PRIS/100 ST								
Diameter	Längd	Pris	Förp.	Grepp	Splintdia.	Skalldiam.	Skallhöjd	Borrdiam.
Ø 3.2	10	X	500/4000	6,00	1,80	6,50	0,80	3,50
Ø 4.0	8	X	500/4000	4,00	2,20	8,00	1,00	4,30
	12	X	500/3000	6,00				
	16	X	500/3000	8,00				
Ø 4.8	8	X	500/3000	4,00	2,75	9,50	1,10	5,10
	10	X	500/3000	6,00				
	12	X	500/3000	8,00				
	14	X	250/2000	10,00				
	18	X	250/1500	13,00				
	21	X	250/1500	15,00				
24	X	200/1200	20,00					

ÖVRIGA DIMENSIONER OCH LÄNGDER MOT FÖRFRÅGAN !

BESTÄLLNINGSEXEMPEL: 11341048140 - KBLBH-AL/ST 4.8X14

SWEBOLT AB

TEL 08 - 555 975 00 FAX 08 - 583 581 82

13:47

ARTIKELLISTA
2013-2014
BLINDNIT FÖRSÄNKT HUVUD MULTIGRIP
NIT ALUMINIUM / SPLINT STÅL DACROMET
FBLMG-AL/ST



C:A PRIS/100 ST								
Diameter	Längd	Pris	Förp.	Grepp	Splintdia.	Skalldiam.	Skallhöjd	Borrdiam.
Ø 3.2	9,5	X	500/4000	0,5-6,0	1,80	5,80	1,80	3,3-3,5
Ø 4.0	11	X	500/3000	2,0-8,0	2,20	7,30	1,30	4,1-4,3
Ø 4.8	12	X	500/3000	2,0-7,5	2,75	8,80	1,60	4,9-5,1
	16,5	X	250/1500	6,0-12,0				

ÖVRIGA DIMENSIONER OCH LÄNGDER MOT FÖRFRÅGAN !

BESTÄLLNINGSEXEMPEL: 11351040110 - FBLMG-AL/ST 4.0X11

SWEBOLT AB
TEL 08 - 555 975 00 FAX 08 - 583 581 82



ARTIKELLISTA

2013-2014

BLINDNIT FÖRSÄNKT 120° HUVUD TRYCKTÄT NIT ALUMINIUM / SPLINT STÅL TFBL-AL/ST

C:A PRIS/100 ST								
Diameter	Längd	Pris	Förp.	Grepp	Splintdia.	Skalldiam.	Skallhöjd	Borrdiam.
Ø 4.8	10	X	500/3000	4,5-6,0	2,60	9,50	1,50	4,90
	12	X	500/3000	6,0-8,0				
	14,5	X	250/2000	8,0-10,0				
	16	X	250/2000	10,0-12,0				

ÖVRIGA DIMENSIONER OCH LÄNGDER MOT FÖRFRÅGAN !

BESTÄLLNINGSEXEMPEL: 11355048120 - TFBL-AL/ST 4,8X12

SWEBOLT AB

TEL 08 - 555 975 00 FAX 08 - 583 581 82

13:51



ARTIKELLISTA

2013-2014

BLINDNIT ROSETTNIT FÖR MJUKA MATERIAL NIT ALUMINIUM / SPLINT ALUMINIUM RKBL-AL/AL

C:A PRIS/100 ST								
Diameter	Längd	Pris	Förp.	Grepp	Splintdia.	Skalldiam.	Skallhöjd	Borrdiam.
Ø 4.0	13,6	X	500/3000	1,0-3,0	2,40	8,00	1,40	4,2-4,5
	18,8	X	250/2000	1,0-7,0				
	24,5	X	250/1500	4,0-12,0				
Ø 4.8	15,3	X	250/2000	1,0-3,0	2,90	8,80	1,60	5,0-5,3
	20,5	X	250/1500	1,0-9,0				
	24,5	X	200/1200	4,0-12,0				
	28	X	200/1200	6,0-16,0				

BESTÄLLNINGSEXEMPEL: 11360048153 - RKBL-AL/AL 4.8X15.3



NIT ALUMINIUM / SPLINT ALUMINIUM SRKBL-AL/AL MED STOR SKALLE

C:A PRIS/100 ST								
Diameter	Längd	Pris	Förp.	Grepp	Splintdia.	Skalldiam.	Skallhöjd	Borrdiam.
Ø 4.0	18,8	X	250/2000	1,0-7,0	2,40	12,00	1,40	4,2-4,5
Ø 4.8	15,3	X	250/2000	1,0-3,0	2,90	9,30	1,60	5,0-5,3
	20,5	X	250/1500	1,0-9,0				
	24,5	X	200/1200	4,0-12,0				
Ø 4.8	20,5	X	200/1200	1,0-9,0	2,40	14,00	1,60	5,0-5,3

BESTÄLLNINGSEXEMPEL: 11361048153 - SRKBL-AL/AL 4.8X20.5

SWEBOLT AB

TEL 08 - 555 975 00 FAX 08 - 583 581 82

ARTIKELLISTA
2013-2014
MONOBOLT KULLRIG
NIT ALUMINIUM / SPLINT ALUMINIUM
MONOK-AL/AL



C:A PRIS/100 ST								
Diameter	Längd	Pris	Förp.	Grepp	Splintdia.	Skalldiam.	Skallhöjd	Borrdiam.
Ø 6.5	14	X	1500	1,0-9,5	4,00	13,00	2,50	6,6-7,0
	20	X	1000	2,0-16,0				

BESTÄLLNINGSEXEMPEL: 11394065140 - MONOK-AL/AL 6.5X14

MONOBOLT FÖRSÄNKT
NIT ALUMINIUM / SPLINT ALUMINIUM
MONOF-AL/AL



C:A PRIS/100 ST								
Diameter	Längd	Pris	Förp.	Grepp	Splintdia.	Skalldiam.	Skallhöjd	Borrdiam.
Ø 6.5	16	X	1500	1,0-12,0	4,00	11,20	2,20	6,6-7,0

BESTÄLLNINGSEXEMPEL: 11394265140 - MONOF-AL/AL 6.5X16



ARTIKELLISTA
2013-2014
MONOBOLT KULLRIG
NIT STÅL FZG / SPLINT STÅL FZB
MONOK-ST/ST

C:A PRIS/100 ST								
Diameter	Längd	Pris	Förp.	Grepp	Splintdia.	Skalldiam.	Skallhöjd	Borrdiam.
Ø 4.8	10,3	X	2000	1,5-6,8	3,00	9,70	1,80	4,9-5,1
	13,5	X	2000	1,5-11,0				
Ø 6.5	14	X	1500	1,0-9,5	4,00	13,00	2,50	6,6-7,0
	20	X	1000	2,0-16,0				

BESTÄLLNINGSEXEMPEL: 11394448100 - MONOK-ST/ST 4.8X10



MONOBOLT FÖRSÄNKT
NIT STÅL FZG / SPLINT STÅL FZB
MONOF-ST/ST

C:A PRIS/100 ST								
Diameter	Längd	Pris	Förp.	Grepp	Splintdia.	Skalldiam.	Skallhöjd	Borrdiam.
Ø 6.5	16	X	1500	1,0-12,0	4,00	11,20	2,20	6,6-7,0

BESTÄLLNINGSEXEMPEL: 11394665160 - MONOF-ST/ST 6.5X16

SWEBOLT AB

TEL 08 - 555 975 00 FAX 08 - 583 581 82

ARTIKELLISTA
2013-2014
MONOBOLT KULLRIG
NIT ROSTFRI / SPLINT ROSTFRI
MONORK-A2/A2



C:A PRIS/100 ST								
Diameter	Längd	Pris	Förp.	Grepp	Splintdia.	Skalldiam.	Skallhöjd	Borrdiam.
Ø 6.5	14	X	1500	1,0-9,5	4,00	13,00	2,50	6,6-7,0
	20	X	1000	2,0-11,0				

BESTÄLLNINGSEXEMPEL: 21394465140 - MONORK-A2/A2 6.5X20

SWEBOLT AB
TEL 08 - 555 975 00 FAX 08 - 583 581 82

ARTIKELLISTA

2013-2014

BLINDNITMUTTER ÖPPEN PLAN SKALLE STÅL PBMÖS - SLÄT



C:A PRIS/100 ST								
Dimension	Grepp	Pris	Förp.	Längd	D1	D2	Skallhöjd	Borrdiam.
M4	0,25-3,0	X	500/4000	9.5	6,00	9,00	1,00	6.1
	3,0-4,5	X	500/4000	11.5	6,00	9,00	1,00	6.1
M5	0,25-3,0	X	500/4000	12,00	7,00	10,00	1,00	7.1
	3,0-5,5	X	500/4000	15,00	7,00	10,00	1,00	7.1
M6	0,5-3,0	X	500/3000	14.5	9,00	13,00	1.5	9.1
	3,0-5,5	X	500/3000	16.5	9,00	13,00	1.5	9.1
M8	0,5-3,0	X	250/1500	16.5	11,00	16,00	1.5	11.1
	3,0-5,5	X	250/1500	18.5	11,00	16,00	1.5	11.1
M10	1,0-3,5	X	150/900	17.5	11.9	16,00	1.7	12,00
M12	1,0-4,0	X	500	25,00	16	23,00	2,00	16,10

BESTÄLLNINGSEXEMPEL: 1137010412 - PBMÖS M4X11,5 STÅL

BLINDNITMUTTER ÖPPEN PLAN LÄTTRAD SKALLE STÅL PBMÖRS - RÄFFLAD



C:A PRIS/100 ST								
Dimension	Grepp	Pris	Förp.	Längd	D1	D2	Skallhöjd	Borrdiam.
M3	0,25-2,0	X	500/4000	9,75	5,00	7,50	1,00	5,10
M4	0,25-3,0	X	500/4000	9,50	6,00	9,00	1,00	6,10
	3,0-4,5	X	500/4000	12,25	6,00	9,00	1,00	6,10
M5	0,25-3,0	X	500/4000	12,00	7,00	10,00	1,00	7,10
	3,0-5,5	X	500/4000	15,00	7,00	10,00	1,00	7,10
M6	0,5-3,0	X	250/2000	14,50	9,00	13,00	1,50	9,10
	3,0-5,5	X	250/1500	16,50	9,00	13,00	1,50	9,10
M8	0,5-3,0	X	250/1500	16,50	11,00	16,00	1,50	11,10
	3,0-5,5	X	250/1500	18,50	11,00	16,00	1,50	11,10
M10	0,5-3,5	X	150/900	19,50	13,00	19,00	2,00	13,10
	3,5-6,0	X	100/600	21,50	13,00	19,00	2,00	13,10
M12	1,0-4,0	X	500	25,00	16,00	23,00	2,00	16,10

BESTÄLLNINGSEXEMPEL: 1138510615 - PBMÖRS M6x14,5 FZG

ÖVRIGA DIMENSIONER OCH LÄNGDER MOT FÖRFRÅGAN !

SWEBOLT AB

TEL 08 - 555 975 00 FAX 08 - 583 581 82

13:70



ARTIKELLISTA

2013-2014

BLINDNITMUTTER ÖPPEN LITEN SKALLE STÅL - REDUCERAD SFBMÖS - SLÄT

C:A PRIS/100 ST								
Dimension	Grepp	Pris	Förp.	Längd	D1	D2	Skallhöjd	Borrdiam.
M3	0,5-1,5	X	500/4000	8,70	4,92	5,40		5,10
M4	0,5-2,0	X	500/4000	10,40	6,30	6,70		6,40
M5	0,5-3,0	X	500/4000	11,50	7,10	7,90		7,20
M6	0,7-3,0	X	500/3000	14,50	9,50	10,20		9,60
M8	0,8-4,5	X	250/1500	16,00	10,50	11,30		10,60

BESTÄLLNINGSEXEMPEL: 1137160309 - SFBMÖS M3x8,7 FZG



BLINDNITMUTTER ÖPPEN LITEN LÄTTRAD SKALLE STÅL - REDUCERAD SFBMRÖS - RÄFFLAD

C:A PRIS/100 ST								
Dimension	Grepp	Pris	Förp.	Längd	D1	D2	Skallhöjd	Borrdiam.
M4	0,5-2,0	X	500/4000	10,40	6,00	7,00		6,10
M5	0,5-3,0	X	500/4000	11,50	7,00	8,00		7,10
M6	0,5-3,0	X	500/3000	14,50	9,00	10,00		9,10
	3,0-5,5	X	250/2000	16,50	9,00	10,00		9,10
M8	0,8-4,5	X	250/1500	16,80	11,00	12,00		11,10
M10	0,7-3,5	X	150/900	20,80	13,00	14,00		13,10

BESTÄLLNINGSEXEMPEL: 1139360615 - SFBMRÖS M6x14,5 FZG

SWEBOLT AB

TEL 08 - 555 975 00 FAX 08 - 583 581 82

ARTIKELLISTA

2013-2014

BLINDNITMUTTER ÖPPEN PLAN SKALLE ALUMINIUM PBMÖAL



C:A PRIS/100 ST								
Dimension	Grepp	Pris	Förp.	Längd	D1	D2	Skallhöjd	Borrdiam.
M4	0,25-3,0	X	500/4000	9,50	6,00	9,00	1,00	6,10
M5	0,5-3,0	X	500/4000	12,00	7,00	10,00	1,00	7,10
	3,0-5,5	X	500/4000	15,00	7,00	10,00	1,00	7,10
M6	0,5-3,0	X	250/200	14,50	9,00	13,00	1,50	9,10
	3,0-5,5	X	250/1500	16,50	9,00	13,00	1,50	9,10
M8	0,5-3,0	X	250/1500	16,50	11,00	15,00	1,50	11,10
	3,0-5,5	X	250/1500	18,50	11,00	15,00	1,50	11,10

BESTÄLLNINGSEXEMPEL: 113720060 - PBMÖAL M6X14.5 ALUMINIUM

BLINDNITMUTTER ÖPPEN PLAN LITEN SKALLE ALUMINIUM - REDUCERAD SFBMRÖAL



C:A PRIS/100 ST								
Dimension	Grepp	Pris	Förp.	Längd	D1	D2	Skallhöjd	Borrdiam.
M6	0,5-3,0	X	500/3000	14,50	9,00	10,00		9,10

BESTÄLLNINGSEXEMPEL: 113730060 - SFBMRÖAL M6X14.5 ALUMINIUM

SWEBOLT AB

TEL 08 - 555 975 00 FAX 08 - 583 581 82



ARTIKELLISTA

2013-2014

BLINDNITMUTTER ÖPPEN FÖRSÄNKT SKALLE STÅL - LÄTTRAD - 90° FBMÖRS - RÄFFLAD

C:A PRIS/100 ST								
Dimension	Grepp	Pris	Förp.	Längd	D1	D2	Skallhöjd	Borrdiam.
M4	1,0-3,0	X	500/4000	11,50	6,00	9,00	1,50	6,10
M5	1,5-4,0	X	500/4000	13,00	7,00	10,00	1,50	7,10
M6	1,5-4,0	X	500/3000	16,00	9,00	12,00	1,50	9,10
M8	1,5-4,0	X	250/1500	19,00	11,00	14,00	1,50	11,10

BESTÄLLNINGSEXEMPEL: 113856050 - FBMÖRS M5X13



STÅL - SJÄLVFÖRSÄNKANDE FBMÖS

C:A PRIS/100 ST								
Dimension	Grepp	Pris	Förp.	Längd	D1	D2	Skallhöjd	Borrdiam.
M3	0,5-1,5	X	500/4000	8,70	4,90	5,40	0,10	5,10
M4	1,0-3,0	X	500/4000	10,40	6,30	6,70	0,10	6,40
M5	1,5-4,0	X	500/4000	11,50	7,10	7,90	0,10	7,20
M6	1,5-4,0	X	500/3000	14,50	9,50	10,20	0,10	9,60
M8	1,5-4,0	X	250/1500	16,00	10,50	11,30	0,10	10,60

BESTÄLLNINGSEXEMPEL: 113751050 - FBMÖS M5x11,5 FZG

SWEBOLT AB

TEL 08 - 555 975 00 FAX 08 - 583 581 82



ARTIKELLISTA

2013-2014

BLINDNITMUTTER SEXKANT ÖPPEN SKALLE STÅL P6BMÖS

C:A PRIS/100 ST								
Dimension	Grepp	Pris	Förp.	Längd	D1	D2	Skallhöjd	SEKANT
M4	0,25-2,0	X	500/4000	10,00	6,00	9,00	1,00	6,10
M5	0,5-3,0	X	500/4000	13,00	7,00	10,00	1,00	7,10
M6	0,5-3,0	X	250/2000	14,50	9,00	13,00	1,50	9,10
M8	0,5-3,0	X	250/1500	16,50	11,00	16,00	1,50	11,10
	3,0-5,5	X	250/1500	19,50	11,00	16,00	1,50	11,10
M10	1,0-3,5	X	150/900	21,00	13,00	19,00	2,00	13,10
M12	1,0-4,0	X	100/600	25,00	16,00	23,00	2,00	16,10

BESTÄLLNINGSEXEMPEL: 1139010410 - P6BMÖS M4x10 FZG



BLINDNITMUTTER SEXKANT LITEN ÖPPEN SKALLE STÅL - RECUDERAD SF6BMÖS

C:A PRIS/100 ST								
Dimension	Grepp	Pris	Förp.	Längd	D1	D2	Skallhöjd	SEKANT
M4	0,25-2,0	X	500/4000	11,00	6,00	6,60		6,10
M5	0,5-3,0	X	500/4000	14,00	7,00	7,70		7,10
M6	0,5-3,0	X	500/3000	16,00	9,00	9,80		9,10
M8	0,5-3,0	X	250/1500	18,00	11,00	11,80		11,10
M10	0,5-3,5	X	150/900	19,00	13,00	14,00		13,10
M12	1,0-4,0	X	100/600	25,00	16,00	17,50		16,10

BESTÄLLNINGSEXEMPEL: 1139210616 - SF6BMÖS M6x16 FZG

SWEBOLT AB

TEL 08 - 555 975 00 FAX 08 - 583 581 82

ARTIKELLISTA

2013-2014

BLINDNITMUTTER ÖPPEN PLAN SKALLE ROSTFRI A2 - LÄTTRAD UNDER SKALLEN PBMÖS



C:A PRIS/100 ST								
Dimension	Grepp	Pris	Förp.	Längd	D1	D2	Skallhöjd	Borrdiam.
M4	0,25-2,0	X	500/4000	10,00	6,00	9,00	1,00	6,10
M5	0,5-3,0	X	500/4000	11,50	7,00	10,00	1,00	7,10
M6	0,5-3,0	X	250/2000	14,50	9,00	13,00	1,50	9,10
M8	0,5-3,0	X	250/1500	16,00	11,00	16,00	1,50	11,10

BESTÄLLNINGSEXEMPEL: 2137300410 - PBMÖRS M4X10 A2

BLINDNITMUTTER ÖPPEN PLAN LITEN SKALLE ROSTFRI A2 - REDUCERAD SFBMÖS



C:A PRIS/100 ST								
Dimension	Grepp	Pris	Förp.	Längd	D1	D2	Skallhöjd	Borrdiam.
M4	0,5-2,0	X	500/4000	11,00	6,00	7,00		6,10
M5	0,5-3,0	X	500/4000	12,00	7,00	8,00		7,10
M6	0,5-3,0	X	500/3000	14,50	9,00	10,00		9,10
M8	0,5-3,0	X	250/1500	16,00	11,00	12,00		11,10

BESTÄLLNINGSEXEMPEL: 2137320615 - SFBMÖS M6X15 A2

BLINDNITMUTTER SEXKANT ÖPPEN PLAN LITEN SKALLE ROSTFRI A2 - REDUCERAD SF6BMÖS

C:A PRIS/100 ST								
Dimension	Grepp	Pris	Förp.	Längd	D1	D2	Skallhöjd	SE XKANT
M4	0,5-2,5	X	500/4000	10,60	5,90	6,80		6,00
M5	0,5-3,0	X	500/4000	11,60	6,90	8,00		7,00
M6	0,7-3,0	X	500/3000	14,50	8,90	10,00		9,00
M8	0,8-3,3	X	250/1500	15,80	10,90	12,00		11,00

BESTÄLLNINGSEXEMPEL: 2137340512 - SF6BMÖS M5X12 A2

SWEBOLT AB

TEL 08 - 555 975 00 FAX 08 - 583 581 82

13:80

ARTIKELLISTA

2013-2014



BLINDNITMUTTER SEXKANT LITEN ÖPPEN SKALLE STÅL - RECUDERAD "HALVHEX" SF6BMKÖS

C:A PRIS/100 ST								
Dimension	Grepp	Pris	Förp.	Längd	D1	D2	Skallhöjd	SEKANT
M4	0,5-2,0	X	500/4000	10,50	6,30	7,80		6,40
M5	0,5-2,5	X	500/4000	12,00	7,10	8,80		7,30
M6	0,7-3,0	X	500/3000	15,00	9,50	11,20		9,60
M8	0,8-3,0	X	250/1500	16,00	10,50	12,20		10,60

BESTÄLLNINGSEXEMPEL: 1139400411 - SF6BMKÖS M4x10,5 FZG

SWEBOLT AB

TEL 08 - 555 975 00 FAX 08 - 583 581 82

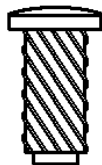

ARTIKELLISTA
2013-2014
DRIVNIT
KDS
STÅL - FÖRNICKLAD

N:R	00	0	2	4	6	7	8	10	12
DIM	1.47	1.85	2.49	2.89	3.5	3.86	4.16	4.55	5.3
Skalld	2.5	3.2	4.1	5.4	6.6	7.24	7.85	9.12	10.36
Skallh	0.86	1.24	1.75	2.18	2.61	2.82	3.05	3.48	3.89
Mått	C:A PRIS/100 ST								
3 (3.17)	X	X	X						
5 (4.76)	X	X	X	X					
6 (6.35)	X	X	X	X	X				
8 (7.93)			X	X	X	X			
10 (9.52)				X	X	X	X	X	
12 (12.7)						X	X	X	X
16 (15.87)							X	X	
19 (19.05)									X

ÖVRIGA DIMENSIONER OCH LÄNGDER MOT FÖRFRÅGAN !

FÖRP.	00	0	2	4	6	7	8	10	12
1000 ST	3-	3-	3-						
500 ST				5-	6-	8-	10-	10-	12-

BESTÄLLNINGSEXEMPEL: 11302001905 - KDS 0X5 STÅL

SWEBOLT AB

TEL 08 - 555 975 00 FAX 08 - 583 581 82

ARTIKELLISTA

2013-2014
DRIVNIT
KDS
ROSTFRI A2

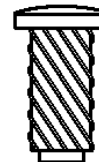

N:R	00	0	2	4	6	7	8	10	12
DIM	1.47	1.85	2.49	2.89	3.5	3.86	4.16	4.55	5.3
Skalld	2.5	3.2	4.1	5.4	6.6	7.24	7.85	9.12	10.36
Skallh	0.86	1.24	1.75	2.18	2.61	2.82	3.05	3.48	3.89
Mått	C:A PRIS/100 ST								
3 (3.17)	X	X	X						
5 (4.76)	X	X	X	X					
6 (6.35)	X		X	X					
8 (7.93)				X					
10 (9.52)				X	X				
12 (12.7)									
16 (15.87)									
19 (19.05)									
FÖRP.	00	0	2	4	6	7	8	10	12
1000 ST	3-	5-							
500 ST			3-						
200 ST				5-					











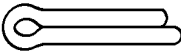

BESTÄLLNINGSEXEMPEL: 21302001905 - KDS 0X5 A2

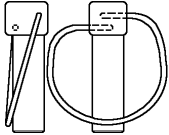
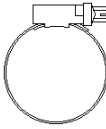
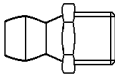
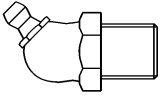
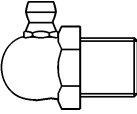
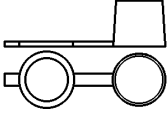
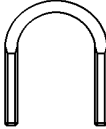
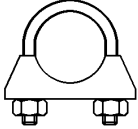
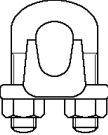
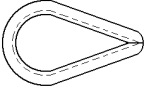
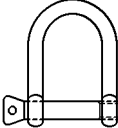
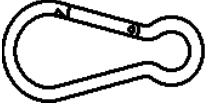
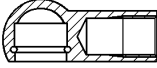
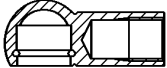
ÖVRIGA DIMENSIONER OCH LÄNGDER MOT FÖRFRÅGAN !

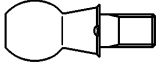
SWEBOLT AB

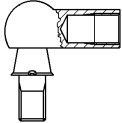
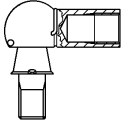
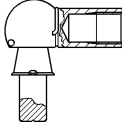
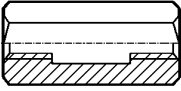
TEL 08 - 555 975 00 FAX 08 - 583 581 82

13:112

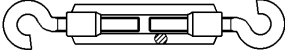
- 1 - 	- 2 - 	- 3 - 	- 4 - 
- 5 - 	- 6 - 	- 7 - 	- 8 - 
- 9 - 	- 10 - 	- 11 - 	- 12 - 
- 13 - 	- 14 - 	- 15 - 	- 16 - 
- 17 - 	- 18 - 	- 19 - 	- 20 - 
- 21 - 	- 22 - 	- 23 - 	- 24 - 
- 25 - 	- 26 - 	- 27 - 	- 28 - 
- 29 - 	- 30 -	- 31 -	- 32 -

SWEBOLT AB

TEL. 08-584 909 60 FAX. 08-583 581 82

PRODUKTER I STÅL

1	114000	SP, SAXPINNE	94	1234		OBEH	14:1
1	114001	SP, SAXPINNE	94	1234		FZB	14:1
2	114010	LN, LÅSNÅL	11024			FZB	14:2
3	114020	DLN, DUBBEL LÅSNÅL	11024			FZB	14:2
4	114012	LNN, BRUTEN NACKE				FZB	14:2
5	114030	LS, LÅSSPRINT, (TRAKTORSPRINT)				FZB	14:2
	114032	LSR, LÅSRING FÖR AXEL/RÖR				FZG	14:2
6	114040	SL, SLANGKLAMMER ABA				FZB	14:16-18
7	114100	SMÖRJNIPPEL, RAK				OBEH	14:3
7	114101	SMÖRJNIPPEL, RAK				FZB	14:3
8	114110	SMÖRJNIPPEL, 45°				OBEH	14:3
8	114111	SMÖRJNIPPEL, 45°				FZB	14:3
9	114120	SMÖRJNIPPEL, 90°				OBEH	14:3
9	114121	SMÖRJNIPPEL, 90°				FZB	14:3
10	114180	SKYDDSHUV FÖR SMÖRJNIPPEL				NYLON	14:3
11	114300	KLAMMER	3570A			OBEH	14:5
11	114301	KLAMMER	3570A			FZB	14:5
11	114302	KLAMMER				OBEH	14:6
11	114303	KLAMMER				FZB	14:6
11	114304	KLAMMER				FZV	14:6
12	114320	AVGASKLAMMER				OBEH	14:4
12	114321	AVGASKLAMMER				FZB	14:4
13	114340	VAJERLÅS	741			FZB	14:7
13	114341	VAJERLÅS	741			FZV	14:7
14	114360	KAUSER	6899			FZB	14:8
14	114361	KAUSER	6899			FZV	14:8
15	114380	SCHACKEL, FÖR KEDJA				FZV	14:9
15	114381	SCHACKEL, RUND TYP				FZV	14:9
16	114400	KH, KARBINHAKE				OBEH	14:10
16	114401	KH, KARBINHAKE				FZB	14:10
17	114420	KULLED SHÅLLARE	71805A				14:11
18	114421	KULLED SHÅLLARE	71805B				14:11
19	114430	LÅSFJÄDER FÖR KULLED					14:11

BILD	ART.GR.	BENÄMNING	DIN	ISO	KVAL	YTBEH	SIDA
20	114350	KULTAPP MED GÄNGA	71803C				14:11
21	114351	KULTAPP UTAN GÄNGA FÖR NITNING	71803B				14:11
22	114440	KOMP. KULLED	71802A				14:12
23	114441	KOMP. KULLED MED GÄNGA	71802CS				14:12
24	114442	KOMP. KULLED FÖR NITNING	71802BS				14:12
25	114500	SPÄNNMUTTER	1479			OBEH	14:13
25	114501	SPÄNNMUTTER	1479			FZB	14:13
25	114502	SPÄNNMUTTER	1479			FZV	14:13
26	114520	VANTSKRUV, HYLSA	1480				14:14
26	114521	VANTSKRUV m. PINNBULT	1480				14:14
27	114522	VANTSKRUV m. ÖGELBULT	1480				14:14
28	114523	VANTSKRUV m. ÖGLA+HAKE	1480				14:15
29	114524	VANTSKRUV m. HAKAR	1480				14:15
	114600	KÄTTING				FZV	14:16

ROSTFRITT / SYRAFAST

1	214000	SP, SAXPINNE	94	1234	A2		14:41
1	214001	SP, SAXPINNE	94	1234	A4		14:42
2	214010	LN, LÅSNÅL	11024		A4		14:43
6	214040	SL, SLANGKLAMMER	ABA		A2		14:19
6	214041	SL, SLANGKLAMMER	ABA		A4		14:19
11	214300	KLAMMER			A2		14:43
11	214301	KLAMMER			A4		14:44
13	214340	VAJERLÅS	741		A2		14:45
14	214360	KAUSER	6899		A2		14:46
15	214380	SCHACKEL			A2		14:47
15	214381	SCHACKEL, RUND TYP			A4		14:47

SWEBOLT AB

TEL. 08-584 909 60 FAX. 08-583 581 82

ARTIKELLISTA
2013-2014
SAXPINNE
SP DIN 94 / ISO 1234
BLANKFÖRZINKAD



DIM	1	1.2	1.6	2	2.5	3.2	4	5	6.3	8	10	13
d max	0.9	1	1.4	1.8	2.3	2.9	3.7	4.6	5.9	7.5	9.5	12.4
d min	0.8	0.9	1.3	1.7	2.1	2.7	3.5	4.4	5.7	7.3	9.3	12.1
a	3	3	3.2	4	5	6.4	8	10	12.6	16	20	23
c max	1.8	2	2.8	3.6	4.6	5.8	7.4	9.2	11.8	15	19	24.8
c min	1.6	1.7	2.4	3.2	4	5.1	6.5	8	10.3	13.1	16.6	21.7
e max	1.6	2.5	2.5	2.5	2.5	4	4	4	4	4	6.3	6.3
e min	0.8	1.3	1.3	1.3	1.3	2	2	2	2	2	3.2	3.2
Längd	C:A PRIS / 100 ST											
6	X	X										
8	X	X	X	X	X	X						
10	X	X	X	X	X	X						
12	X	X	X	X	X	X						
14	X	X	X	X	X	X						
16	X	X	X	X	X	X	X					
18	X	X	X	X	X	X	X					
20	X	X	X	X	X	X	X	X				
22	X	X	X	X	X	X	X	X				
25	X	X	X	X	X	X	X	X	X			
28	X	X	X	X	X	X	X	X	X			
32	X	X	X	X	X	X	X	X	X			
36	X	X	X	X	X	X	X	X	X			
40	X	X	X	X	X	X	X	X	X	X		
45		X	X	X	X	X	X	X	X	X		
50		X	X	X	X	X	X	X	X	X	X	
56					X	X	X	X	X	X	X	
63					X	X	X	X	X	X	X	
71							X	X	X	X	X	
80							X	X	X	X	X	X
90							X	X	X	X	X	X
100							X	X	X	X	X	X
112								X	X	X	X	X
125								X	X	X	X	X
140									X	X	X	X
160										X	X	X
180										X	X	X
200											X	X
250												X

ÖVRIGA DIMENSIONER OCH LÄNGDER MOT FÖRFRÅGAN !

FÖRP.	1	1.2	1.6	2	2.5	3.2	4	5	6.3	8	10	13
	1000	1000	1000	1000	1000	1000	1000	500	250	100	100	25

BESTÄLLNINGSEXEMPEL: 11400101612 - SP 1.6X12 FZB

SWEBOLT AB

TEL 08 - 555 975 00 FAX 08 - 583 581 82

ARTIKELLISTA
2013-2014
LN LÅSNÅL
RAK
BLANKFÖRZINKAD



C:A PRIS/100 ST				
DIM	LÄNGD	ÖGLA	KLÄMLÄNGD	PRIS
1.25	20	3	2	X
1.5	22.7	3.7	2,5	X
1.75	23	3.8	2	X
2.0	41	9	3	X
3.0	67	1	4	X
3.5	75	17.5	74	X
4.0	75	19	4	X
5.0	105	26	7	X
6.0	117	31	8	X
7.0	165	39	12	X
8.0	165	38	11	X

BESTÄLLNINGSEXEMPEL: 114010035 - LN 3.5mm FZB

LNN LÅSNÅL BRUTEN NACKE
BLANKFÖRZINKAD



C:A PRIS/100 ST				
DIM	LÄNGD	ÖGLA	KLÄMLÄNGD	PRIS
2.0	43	10	3	X
2.5	45	10	2	X
3.0	54	13	3	X
3.5	67	17	4	X
4.0	75	19	4	X
5.0	107	27	5	X
6.0	117	31	11	X

BESTÄLLNINGSEXEMPEL: 114012040 - LNN 4mm FZB BRUTEN

LÅSSPRINT / TRAKTORSPRINT
LS BLANKFÖRZINKAD



C:A PRIS/100 ST				
DIM	LÄNGD	ÖGLA	KLÄMLÄNGD	PRIS
4.5	32	25.4	3	X
4.5	40	32.5	3,5	X
6.0	40	32.5	3,5	X
8.0	40	32.5	3,5	X
9.0	45	35	3,5	X
10.0	40	34.5	3,5	X
10.0	45	34.5	3,5	X

BESTÄLLNINGSEXEMPEL: 11403008040 - LS 8mm/40 FZG

ÖVRIGA DIMENSIONER OCH LÄNGDER MOT FÖRFRÅGAN !

SWEBOLT AB

TEL 08 - 555 975 00 FAX 08 - 583 581 82

ARTIKELLISTA

2013-2014

SMÖRJNIPPEL RAK SNR TYP A FZB



C:A PRIS/100 ST					
DIM	GL	NV	TOTL max	PRIS	FÖRP
R 1/8	6	11	16	X	200 ST
M6X1	5.5	7	16	X	200 ST
R 1/4	6	14	16	X	200 ST
M8X1.25	5.5	9	16	X	200 ST
M8X1	5.5	9	16	X	200 ST
M10X1	5.5	11	16	X	200 ST

BESTÄLLNINGSEXEMPEL: 114101060 - SNR M6X1 RAK FZB

SMÖRJNIPPEL 45° SN45 TYP B FZB



C:A PRIS/100 ST					
DIM	GL	NV	TOTL max	PRIS	FÖRP
R 1/8	6	11	22	X	200 ST
M6X1	5.5	9	21	X	200 ST
R 1/4	6	14	22	X	200 ST
M8X1.25	5.5	9	21	X	200 ST
M8X1	5.5	9	21	X	200 ST
M10X1	5.5	11	21	X	200 ST

BESTÄLLNINGSEXEMPEL: 114111060 - SN45 M6X1 45G-RADER FZB

SMÖRJNIPPEL 90° SN90 TYP C FZB



C:A PRIS/100 ST					
DIM	GL	NV	TOTL max	PRIS	FÖRP
R 1/8	5,5	11	19	X	200 ST
M6X1	5.5	9	18	X	200 ST
R 1/4	5,5	14	19	X	200 ST
M8X1.25	5.5	9	18	X	200 ST
M8X1	5.5	9	18	X	200 ST
M10X1	5.5	11	18	X	200 ST

BESTÄLLNINGSEXEMPEL: 114121060 - SN90 M6X1 90-GRADER FZB

SMÖRJNIPPEL RAK ROSTFRI A2



C:A PRIS/100 ST					
DIM	GL	NV	TOTL max	PRIS	FÖRP
M6X1	5.5	7	5.5	X	100 ST

BESTÄLLNINGSEXEMPEL: 210515060 - SNR M6X1 A2

SKYDDSHUV MED ÖGLA FÖR SMÖRJNIPPEL

C:A PRIS/100 ST		
FÄRG	PRIS	FÖRP
ORANGE	X	200 ST

BESTÄLLNINGSEXEMPEL: 4110025048 - SKYDDSHUV ORANGE

SWEBOLT AB

TEL 08 - 555 975 00 FAX 08 - 583 581 82

ARTIKELLISTA

2013-2014

RÖRKLAMMER, U-BYGEL, PLÅT 4.6 FZB



C:A PRIS/100 ST								
RÖRKLAMMER (AVGASKLAMMER)			U-BYGEL			PLÅT		
GÄNGA	RÖR	PRIS	GÄNGA	RÖR	PRIS	GÄNGA	RÖR	PRIS
M8	25	X	M8	25	X	M8	25	X
M8	28	X	M8	28	X	M8	28	X
M8	32	X	M8	32	X	M8	32	X
M8	35	X	M8	35	X	M8	35	X
M8	38	X	M8	38	X	M8	38	X
M8	42	X	M8	42	X	M8	42	X
M8	45	X	M8	45	X	M8	45	X
M8	48	X	M8	48	X	M8	48	X
M8	51	X	M8	51	X	M8	51	X
M8	54	X	M8	54	X	M8	54	X
M8	57	X	M8	57	X	M8	57	X
M8	60	X	M8	60	X	M8	60	X
M8	64	X	M8	64	X	M8	64	X
M8	67	X	M8	67	X	M8	67	X
M8	70	X	M8	70	X	M8	70	X
M8	73	X	M8	73	X	M8	73	X
M8	76	X	M8	76	X	M8	76	X
M8	83	X	M8	83	X	M8	83	X
M8	89	X	M8	89	X	M8	89	X
M8	95	X	M8	95	X	M8	95	X
M8	102	X	M8	102	X	M8	102	X
M10	42	X	M10	42	X	M10	42	X
M10	45	X	M10	45	X	M10	45	X
M10	48	X	M10	48	X	M10	48	X
M10	50	X	M10	50	X	M10	50	X
M10	52	X	M10	52	X	M10	52	X
M10	54	X	M10	54	X	M10	54	X
M10	58	X	M10	58	X	M10	58	X
M10	60	X	M10	60	X	M10	60	X

RÖRKLAMMER = BYGEL + PLÅT + MUTTRAR (monterad)

BESTÄLLNINGSEXEMPEL: 11432108035 - RÖRKLAMMER 35mm M8 FZB

BESTÄLLNINGSEXEMPEL: 1143308025 - RÖRKLAMMER 25mm M8 FZB

SWEBOLT AB

TEL 08 - 555 975 00 FAX 08 - 583 581 82

ARTIKELLISTA
2013-2014
SAXPINNE
SP DIN 94 / ISO 1234
SYRAFAST A4













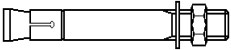
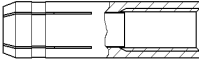

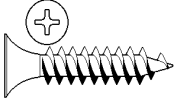
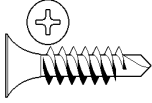
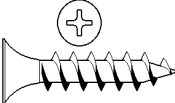
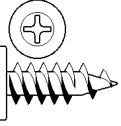
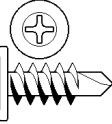
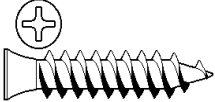
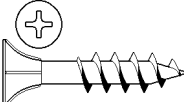
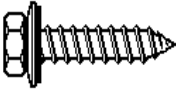

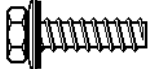
DIM	1	1.2	1.6	2	2.5	3.2	4	5	6.3	8	10	13
d max	0.9	1	1.4	1.8	2.3	2.9	3.7	4.6	5.9	7.5	9.5	12.4
d min	0.8	0.9	1.3	1.7	2.1	2.7	3.5	4.4	5.7	7.3	9.3	12.1
a	3	3	3.2	4	5	6.4	8	10	12.6	16	20	23
c max	1.8	2	2.8	3.6	4.6	5.8	7.4	9.2	11.8	15	19	24.8
c min	1.6	1.7	2.4	3.2	4	5.1	6.5	8	10.3	13.1	16.6	21.7
e max	1.6	2.5	2.5	2.5	2.5	4	4	4	4	4	6.3	6.3
e min	0.8	1.3	1.3	1.3	1.3	2	2	2	2	2	3.2	3.2
Längd	C:A PRIS / 100 ST											
6	X	X	X	X								
8	X	X	X	X								
10	X	X	X	X	X							
12	X	X	X	X	X							
14	X	X	X	X	X							
16	X	X	X	X	X	X	X	X				
18	X	X	X	X	X	X	X	X				
20	X	X	X	X	X	X	X	X	X			
22	X	X	X	X	X	X	X	X	X			
25	X	X	X	X	X	X	X	X	X			
28	X	X	X	X	X	X	X	X	X			
32	X	X	X	X	X	X	X	X	X	X	X	
36	X	X	X	X	X	X	X	X	X	X	X	
40	X	X	X	X	X	X	X	X	X	X	X	
45	X	X	X	X	X	X	X	X	X	X	X	
50					X	X	X	X	X	X	X	
56						X	X	X	X	X	X	
63						X	X	X	X	X	X	
71							X	X	X	X	X	
80							X	X	X	X	X	
90							X	X	X	X	X	X
100							X	X	X	X	X	X
112									X	X	X	X
125									X	X	X	X
140										X	X	X
160												
180												
200												
220												
240												

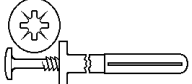
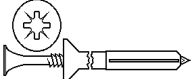
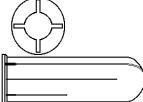
ÖVRIGA DIMENSIONER OCH LÄNGDER MOT FÖRFRÅGAN !

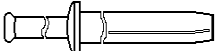
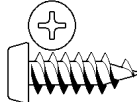
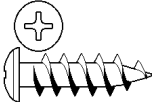
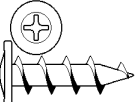
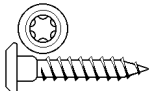
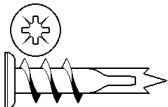
FÖRP.	1	1.2	1.6	2	2.5	3.2	4	5	6.3	8	10	13
	500	500	500	500	500	500	200	200	100	100	50	25



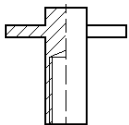
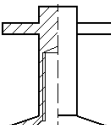

BESTÄLLNINGSEXEMPEL: 21400101632 - SP 1.6X32 A4

SWEBOLT AB
TEL 08 - 555 975 00 FAX 08 - 583 581 82

- 1 - 	- 2 - 	- 3 - 	- 4 - 
- 5 - 	- 6 - 	- 7 - 	- 8 - 
- 9 - 	- 10 - 	- 11 - 	- 12 - 
- 13 - 	- 14 - 	- 15 - 	- 16 - 
- 17 - 	- 18 - 	- 19 - 	- 20 - 
- 21 - 	- 22 - 	- 23 - 	- 24 - 
- 25 - 	- 26 - 	- 27 - 	- 28 - 
- 29 - 	- 30 - 	- 31 - 	- 32 - 

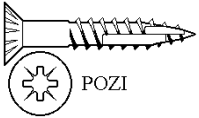
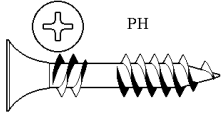
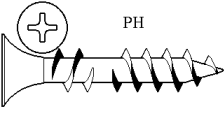
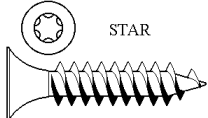
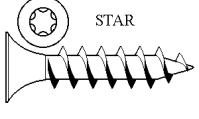
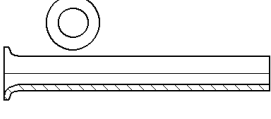
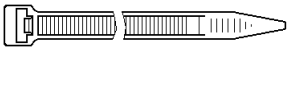
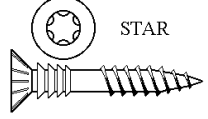
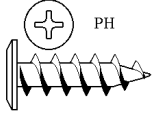
SWEBOLT AB

TEL. 08-584 909 60 FAX. 08-583 581 82

<p align="center">- 33 -</p>  <p align="center">POZI</p>	<p align="center">- 34 -</p>  <p align="center">PH</p>	<p align="center">- 35 -</p>  <p align="center">PH</p>	<p align="center">- 36 -</p>  <p align="center">STAR</p>
<p align="center">- 37 -</p>  <p align="center">STAR</p>	<p align="center">- 38 -</p> 	<p align="center">- 39 -</p> 	<p align="center">- 40 -</p>  <p align="center">STAR</p>
<p align="center">- 41 -</p>  <p align="center">PH</p>	<p align="center">- 42 -</p> 	<p align="center">- 43 -</p> 	<p align="center">- 44 -</p>
<p align="center">- 45 -</p>	<p align="center">- 46 -</p>	<p align="center">- 47 -</p>	<p align="center">- 48 -</p>
<p align="center">- 49 -</p>	<p align="center">- 50 -</p>	<p align="center">- 51 -</p>	<p align="center">- 52 -</p>
<p align="center">- 53 -</p>	<p align="center">- 54 -</p>	<p align="center">- 55 -</p>	<p align="center">- 56 -</p>
<p align="center">- 57 -</p>	<p align="center">- 58 -</p>	<p align="center">- 59 -</p>	<p align="center">- 60 -</p>
<p align="center">- 61 -</p> 	<p align="center">- 62 -</p>	<p align="center">- 63 -</p>	<p align="center">- 64 -</p>

SWEBOLT AB

TEL. 08-584 909 60 FAX. 08-583 581 82

PRODUKTER I STÅL

1	115001	EXPANDERBULT	FZB	15:1
1	115002	EXPANDERBULT	FZV	15:1
2	115011	SLAGANKARE	FZB	15:1
2	115012	SLAGANKARE	FZV	
3	115010	SLAGDORN FÖR SLAGANKARE		15:1
4	115300	KEMANKARE, VDP		15:2
4	115301	KEMANKARE, HAC		15:2
5	115100	GSI, GIPSSKRUV f. STÅLREGEL	FOS	15:3
5	115101	GSI, GIPSSKRUV f. STÅLREGEL	FZB	15:3
34	115102	GSI HS, GIPSSKRUV f. STÅLREGEL HÅRD SKIVA	FOSF	15:3
6	115111	GSII, GIPSSKRUV m. BORRSPETS	FOS	15:3
6	115112	GSII, GIPSSKRUV m. BORRSPETS	FZB	15:3
7	115105	GSIII, GIPSSKRUV f. TRÄREGEL	FOS	15:3
7	115106	GSIII, GIPSSKRUV f. TRÄREGEL	FZB	15:3
8	115020	MSI, MONTAGESKRUV	FZB	15:4
8	115021	MSI, MONTAGESKRUV	VIT	15:4
8	115022	MSI, MONTAGESKRUV	SVART	15:4
9	115025	MSII, MONTAGESKRUV m. BORRSPETS	FZB	15:4
9	115026	MSII, MONTAGESKRUV m. BORRSPETS	VIT	15:4
9	115027	MSII, MONTAGESKRUV m. BORRSPETS	SVART	15:4
10	115260	LS, LISTSKRUV	FZB	15:4
11	115135	SPS, SPÅNSKIVESKRUV m. 4 NIBB	FZB	15:4
	115518	NEOPRENBRICKA		
12	115500	FAS, FARMARSKRUV, SPETSIG	FZB	15:5
12	115501	FAS, FARMARSKRUV, SPETSIG	VIT	15:5
12	115502	FAS, FARMARSKRUV, SPETSIG	SVART	15:5
12	115503	FAS, FARMARSKRUV, SPETSIG	BRUN	15:5
12	115504	FAS, FARMARSKRUV, SPETSIG	GRÅ	15:5
12	115505	FAS, FARMARSKRUV, SPETSIG	RÖD	15:5
13	115520	FASB, FARMARSKRUV, BORRSPETS	FZB	15:5
13	115521	FASB, FARMARSKRUV, BORRSPETS	VIT	15:5
13	115522	FASB, FARMARSKRUV, BORRSPETS	SVART	15:5
13	115523	FASB, FARMARSKRUV, BORRSPETS	BRUN	15:5
13	115524	FASB, FARMARSKRUV, BORRSPETS	GRÅ	15:5
13	115525	FASB, FARMARSKRUV, BORRSPETS	RÖD	15:5

BILD	ART.GR.	BENÄMNING	DIN	ISO	KVAL	YTBEH	SIDA
14	115540	FASP, FARMARSKRUV, PLAN				FZB	15:5
14	115541	FASP, FARMARSKRUV, PLAN				VIT	15:5
14	115542	FASP, FARMARSKRUV, PLAN				SVART	15:5
14	115543	FASP, FARMARSKRUV, PLAN				BRUN	15:5
14	115544	FASP, FARMARSKRUV, PLAN				GRÅ	15:5
14	115545	FASP, FARMARSKRUV, PLAN				RÖD	15:5
15	115560	VENTS, m. FLÄNS, STAR				FZB	15:6
16	115561	VENTB, m. FLÄNS, STAR, BORRSPETS				FZB	15:6
17	115410	SPIKPLUGG, KULLRIG					15:7
17	115415	FASADPLUGG					15:7
18	115420	SPIKPLUGG, FÖRSÄNKT					15:7
19	115400	PLASTPLUGG					15:8
20	115401	NYLONPLUGG					15:8
21	115030	SLAGNIT				ALU/STÅL	15:9
22	115570	MONTAGESKRUV, KULLRIG				FZB	15:10
22	115571	MONTAGESKRUV, KULLRIG				VIT	15:10
23	115575	SKIVSKRUV				FZB	15:10
24	115580	RÄNNKROKSKRUV				FZB	15:10
25	115585	ANKARSKRUV				FZB	15:10
26	115690	DRIVA					15:11
27	115605	GIPSANKARE (MOLLY TYP)					15:12
28	115620	KARMSKRUV					15:13
29	115650	EPOMIX, TUB	160ml				15:2
29	115651	EPOMIX, TUB	360ml				15:2
30	115700	INGJUTNINGSHYLSA				OBEH	15:14
30	115701	INGJUTNINGSHYLSA				FZB	15:14
31	115710	INGJUTNINGSHYLSA m. FLÄNS				OBEH	15:14
31	115711	INGJUTNINGSHYLSA m. FLÄNS				FZB	15:14
32		ANKARPINNAR, SE FLIK 6 PINNSKRUVAR					
42	115631	BETONGSKRUV PLAN				FZG	15:22
43	115633	BETONGSKRUV FÖRSÄNKT				FZG	15:22

SWEBOLT AB

TEL. 08-584 909 60 FAX. 08-583 581 82

ROSTFRITT / SYRAFAST

1	215001	EXPANDER			A4		15:1
2	125011	SLAGANKARE			A4		15:20
30	125700	INGJUTNINGSHYLSA			A2		15:14
31	125710	INGJUTNINGSHYLSA m. FLÄNS			A2		15:14
32		ANKARPINNAR, SE FLIK 6 PINNSKRUVAR					

MÄSSING

2	315011	SLAGANKARE				OBEH	15:20
---	--------	------------	--	--	--	------	-------

NYLON

39	415800	BUNTBAND, NATUR			NYLON		15:21
39	415801	BUNTBAND, SVART			VÄDERBESTÄNDIGT		15:21

VERKTYG

61	159000	SDS PLUS HAMMARBORR					15:80
61	159001	SDS MAX HAMMARBORR					15:81

ARTIKELLISTA

2013-2014

EXPANDERBULT FZB / FZV / SYRAFAST A4 TYPGODKÄND OPT 1 (ETA-08/0173)



C:A PRIS/100 ST					
DIM	Benämning	FZB	FZV	A4	FÖRP.
	6x40	X	X	X	150/750
6/15	6x65	X	X	X	100/500
6/50	6x100	X	X		100/500
	8x52	X	X	X	100/500
8/10	8x72	X	X	X	50/250
8/30	8x92	X	X	X	50/250
8/50	8x112	X	X	X	40/200
8/85	8x147	X	X		40/200
	10x60	X	X	X	50/250
10/10	10x92	X	X	X	25/125
10/20	10x102	X	X		25/125
10/30	10x112	X	X	X	25/125
10/50	10x132	X	X	X	25/125
10/80	10x162	X	X		25/125
12/5	12x103	X	X	X	20/100
12/20	12x118	X	X	X	20/100
12/30	12x128	X	X	X	20/100
12/50	12x148	X	X		20/100
12/65	12x163	X	X	X	20/100
12/80	12x178	X	X		20/100
12/155	12x253	X	X		10/50
	16x90	X			10/50
16/5	16x123	X	X	X	10/50
16/20	16x138	X	X	X	10/50
16/50	16x168	X	X	X	10/50
16/60	16x178	X	X		10/50
16/95	16x213	X	X		5/25
20/20	20x170	X	X	X	5/25
20/70	20x220	X	X	X	5/25
20/130	20x280	X	X		5/25

BESTÄLLNINGSEXEMPEL: 11500110125 - EXP BULT M10/55X125 FZB

BESTÄLLNINGSEXEMPEL: 11500210125 - EXP BULT M10/55X125 FZV

BESTÄLLNINGSEXEMPEL: 21500110125 - EXP BULT M10/55X125 A4

MONTERINGSVERKTYG FÖR EXPANDERBULT. SDS+ FÄSTE

6-10mm 366 KR/ST 12-20mm 478 KR/ST

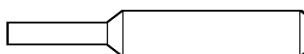

SLAGANKARE

SLAGDORN

ANKARE

C:A PRIS/100 ST				C:A PRIS/100 ST		C:A PRIS/100 ST	
DIM	FZB	A4	FÖRP.	DIM	STÅL	DIM	MASSING
M6	X	X	100/3000	M6	X	M4	X
M8	X	X	100/2000	M8	X	M5	X
M10	X	X	50/500	M10	X	M6	X
M12	X	X	50/500	M12	X	M8	X
M16	X	X	25/200	M16	X	M10	X
M20	X	X	25/100	M20	X	M12	X

BESTÄLLNINGSEXEMPEL: 115011200 - SLAGANKARE M20 FZB

BESTÄLLNINGSEXEMPEL: 115010200 - SLAGDORN 20mm

SWEBOLT AB

TEL 08 - 555 975 00 FAX 08 - 583 581 82

ARTIKELLISTA

2013-2014

GIPSSKIVESKRUV, MONTAGESKRUV

FZB - FOSFATERAD

GIPSSKIVESKRUV GS I FÖR STÅLREGEL

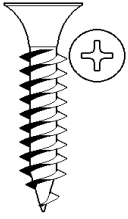

C:A PRIS/100 ST				
DIM	FZB	FZB BULK	FOS	FOS BULK
3.5x25	X	X	X	X
3.5x38	X	X	X	X
3.5x45	X		X	X
3.5x51	X	X	X	X

GIPSSKIVESKRUV GS II MED BORRSPETS

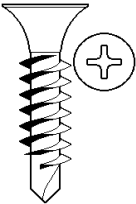

C:A PRIS/100 ST		
DIM	FZB	BULK
3.5x25	X	X
3.5x35	X	X
3.5x45	X	X

GIPSSKIVESKRUV GS III FÖR TRÄREGEL

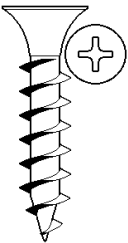

C:A PRIS/100 ST					
DIM	FZB	FZB BULK	FOS	FOS BULK	FZB PLASTBOX
3.5x25	X	X			X
3.9x32	X	X			X
3.9x41	X	X			X
3.9x57	X	X			X
4.2x65	X	X			X
4.2x70		X			X

DIM	FZG	DIM	FZG	DIM	FZG
4.8x50	X	4.8x100	X	4.8x180	X
4.8x60	X	4.8x110	X	4.8x200	X
4.8x70	X	4.8x120	X	4.8x220	X
4.8x80	X	4.8x130	X	4.8x230	X
4.8x90	X	4.8x150	X	4.8x240	X

GIPSSKIVESKRUV GS I FÖR STÅLREGEL - HÅRD SKIVA

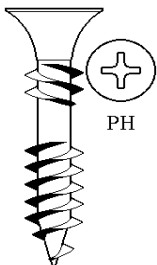

C:A PRIS/100 ST	
FÖR HÅRD SKIVA !	
DIM	FOS BULK
3.8x25	X
3.8x35	X
3.8x45	X

FÖRP.	
1000 ST	SAMTLIGA

BITS FLIK 18

SWEBOLT AB

TEL 08 - 555 975 00 FAX 08 - 583 581 82

ARTIKELLISTA

2013-2014

SPÅNSKIVESKRUV / TRALLSKRUV

SPS FZB

PHILLIPS

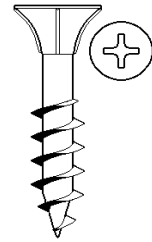

C:A PRIS/100 ST	
DIM	FZB
4.2x25	X
4.2x32	X
4.2x41	X
4.2x51	X
4.2x55	X
4.2x65	X

BESTÄLLNINGSEXEMPEL: 1151354225 - SPS 4.2X25 FZB

FÖRP.
500ST SAMTLIGA

MONTAGESKRUV MS I

SPETSIG

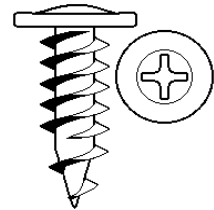

C:A PRIS/100 ST			
	DIM	FZB	FZB BULK
	4.2x14	X	X
	4.2x16	X	
	4.2x19	X	
	4.2x25	X	X
	4.2x32	X	X
	4.2x45	X	
	4.2x65	X	
	4.2x75	X	
VIT	4.2x14	X	
SVART	4.2x14	X	
VIT	4.2x25	X	
SVART	4.2x25	X	

FÖRP
1000 ST SAMTLIGA

MONTAGESKRUV MS II

MED BORRSPETS

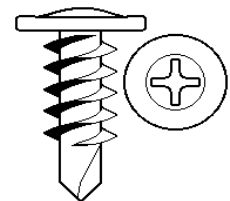

C:A PRIS/100 ST			
	DIM	FZB	FZB BULK
	4.2x14	X	X
	4.2x19	X	X
	4.2x25	X	X
	4.2x32	X	X
	4.2x41	X	
VIT	4.2x14	X	
SVART	4.2x14	X	
VIT	4.2x25	X	
SVART	4.2x25	X	

FÖRP
1000 ST SAMTLIGA

BITS FLIK 18

SWEBOLT AB

TEL 08 - 555 975 00 FAX 08 - 583 581 82

ARTIKELLISTA

2013-2014

FARMARSKRUV MED TÄTNINGSBRICKA FZB + LACKERAD



C:A PRIS / 100ST				
DIM	YTBEHANDLING	SMÅPACK	BULK	ARTIKELNUMMER
4.8x25	FZB	X	X	1155004825
4.8x32	FZB	X	X	1155004832
4.8x38	FZB	X	X	1155004838
4.8x50	FZB	X	X	1155004850
4.8x65	FZB	X	X	1155004865

C:A PRIS / 100ST				
DIM	KULÖR	RR/RAL	SMÅPACK	ARTIKELNUMMER
4.8x25	VIT	20 - 9010	X	1155014825
4.8x25	SVART	33 - 9011	X	1155024825
4.8x25	MÖRK BRUN	32 - 8014	X	1155034825
4.8x25	MÖRK GRÅ	23 - 7043	X	1155044825
4.8x25	TEGELRÖD	750 - 8004	X	1155054825
4.8x25	RÖD	29	X	1155064825
4.8x25	LJUS GRÅ	21 - 7038	X	1155094825
4.8x25	GRÅ	22 - 7015	X	1155104825
4.8x25	RÖD	27 - 3003	X	1155114825
4.8x25	MÖR RÖD	28 - 3009	X	1155124825
4.8x25	BRUN	31 - 8011	X	1155134825
4.8x25	GRÖN	11	X	1155144825
4.8x25	SILVER	40	X	1155154825
4.8x50	SVART	33 - 9011	X	1155024850
4.8x50	VIT	20 - 9010	X	1155014851
4.8x65	MÖRK BRUN	32 - 8014	X	1155034865
4.8x65	SVART	33 - 9011	X	1155024865

FARMARSKRUV BORRSPETS OCH TÄTNINGSBRICKA FZB + LACKERAD



C:A PRIS / 100ST				
DIM	YTBEHANDLING	SMÅPACK	BULK	ARTIKELNUMMER
4.8x28	FZB		X	1155204828
4.8x35	FZB		X	1155204835
4.8x38	FZB			1155204838
4.8x50	FZB		X	1155204850
4.8x65	FZB			1155204865

C:A PRIS / 100ST				
	KULÖR	RR - RAL	SMÅPACK	ARTIKELNUMMER
4.8x28	VIT	20 - 9010	X	1155214828
4.8x28	SVART	33 - 9011	X	1155224828
4.8x28	MÖRKBRUN	32 - 8014	X	1155234828
4.8x28	MÖRK GRÅ	23 - 7043	X	1155244828
4.8x28	TEGELRÖD	750 - 8004	X	1155254828
4.8x28	RÖD	29	X	1155264828
4.8x35	VIT	20 - 9010	X	1155214835
4.8x35	SVART	33 - 9011	X	1155224835

**OBS ! LACKERINGSMÖJLIGHETER FINNS
I ANDRA KULÖRER ÄN OVANSTÅENDE.**

SWEBOLT AB

TEL 08 - 555 975 00 FAX 08 - 583 581 82

ARTIKELLISTA

2013-2014

PLASTPLUGG

TP

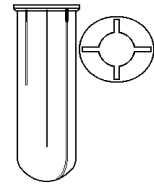

C:A PRIS/100 ST		
DIM	FÄRG	PRIS
TP 0	VIT	X
TP1	GUL	X
TP2	RÖD	X
TB2B	BRUN	X
TP3	BLÅ	X
TP 4	GRÖN	X

BESTÄLLNINGSEXEMPEL: 115400002 - PLASTPLUGG TP 2 RÖD

**SE BYGGPRISLISTA FÖR KOMPLETT
SORTIMENT AV PLUGGAR.
TP PLUGGEN ÄR UTGÅEND!**

SWEBOLT AB

TEL 08 - 555 975 00 FAX 08 - 583 581 82

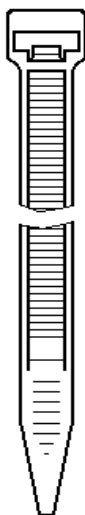

ARTIKELLISTA

2013-2014

BUNTBAND POLYAMID 6.6 NATUR/TRANSPARENT - SVART VÄDERBESTÄNDIGT

C:A PRIS/100 ST					
DIM	NATUR	PRIS	SVART	PRIS	FÖRP.
2.5x100	JS	X	JSS	X	500/5000
2.5x100	JS	X	JSS	X	100/5000
3.5x150	JS	X	JSS	X	500/5000
3.5x150	JS	X	JSS	X	100/5000
4.8x200	JS	X	JSS	X	500/2500
4.8x200	JS	X	JSS	X	100/2500
4.8x300	JS	X	JSS	X	500/2500
4.8x300	JS	X	JSS	X	100/2500
4.8x375	JS	X	JSS	X	500/1500
4.8x375	JS	X	JSS	X	100/1500
7.6x380	JS	X	JSS	X	100/1200
7.6x530	JS	X	JSS	X	100/1000

BESTÄLLNINGSEXEMPEL: 41580025100 - BUNTBAND 2.5X100 NATUR

BESTÄLLNINGSEXEMPEL: 415800251001 - BUNTBAND 2.5X100 NATUR BULK

BESTÄLLNINGSEXEMPEL: 41580125100 - BUNTBAND 2.5X100 SVART

BESTÄLLNINGSEXEMPEL: 415801251001 - BUNTBAND 2.5X100 SVART BULK

SWEBOLT AB

TEL 08 - 555 975 00 FAX 08 - 583 581 82



ARTIKELLISTA
2013-2014
BETONGSKRUV
FÖRSÄNKT/PLAN FZG



C:A PRIS/100 ST							
FÖRSÄNKT				PLAN			
DIM	TORX	SKALLD.	PRIS	DIM	TORX	SKALLD.	PRIS
7.5x42	T-30	10		7.5x42	T-25	7.5	
7.5x72	T-30	10	X	7.5x72	T-25	7.5	X
7.5x92	T-30	10	X	7.5x92	T-25	7.5	X
7.5x112	T-30	10	X	7.5x112	T-25	7.5	X
7.5x132	T-30	10	X	7.5x132	T-25	7.5	X
7.5x152	T-30	10	X	7.5x152	T-25	7.5	X
7.5x182	T-30	10	X	7.5x182	T-25	7.5	X
7.5x212	T-30	10	X	7.5x212	T-25	7.5	X

BESTÄLLNINGSEXEMPEL: 115633075132 - BETONGSKRUV 7.5x132 FZG FÖRSÄNKT

BESTÄLLNINGSEXEMPEL: 115631075092 - BETONGSKRUV 7.5x92 FZG PLAN

FÖRBORRNING Ø6.0mm

FÖRP	FÖRSÄNKT	PLAN
100 ST	SAMTLIGA	SAMTLIGA

SWEBOLT AB

TEL 08 - 555 975 00 FAX 08 - 583 581 82

15:22

ARTIKELLISTA

2013-2014

SDS PLUS

HAMMARBORR



SDS PLUS							
C:A PRIS/STYCK							
Ø mm	Längd	DJUP	PRIS	Ø mm	Längd	DJUP	PRIS
4	110	50	X	14	310	250	X
5	110	50	X	14	450	390	X
5	160	100	X	14	600	540	X
5	210	150	X	14	900		X
5,5	160	100	X	15,0	160	100	X
6	110	50	X	15	210	150	X
6	160	100	X	15	260	200	X
6	210	150	X	15	310	250	X
6	260	200	X	15	450	390	X
6	310	250	X	15	600	540	X
6,5	160	100	X	16,0	160	100	X
7	110	50	X	16	210	150	X
7	160	100	X	16	260	200	X
8	110	50	X	16	310	250	X
8	160	100	X	16	450	390	X
8	210	150	X	16	600	540	X
8	260	200	X	16	800	740	X
8	310	250	X	17	200	140	X
8	400	340	X	18	200	140	X
9	160	100	X	18	300	240	X
9	210	150	X	18	450	390	X
10	130	70	X	18	600	450	X
10	160	100	X	18	800	740	X
10	210	150	X	19	200	140	X
10	260	200	X	20	200	140	X
10	310	250	X	20	300	240	X
10	450	390	X	20	450	390	X
10	600	540	X	20	600	540	X
11	160	100	X	20	800	740	X
11	310	250	X	22	250	190	X
12	160	100	X	22	450	390	X
12	210	150	X	22	600	540	X
12	260	200	X	22	800	740	X
12	310	250	X	24	250	190	X
12	450	390	X	24	450	390	X
12	600	540	X	25	250	190	X
13	160	100	X	25	450	390	X
13	450	390	X	25	600	540	X
14	160	100	X	26	250	190	X
14	210	150	X	26	450	390	X
14	260	200	X				



SDS MAX			
C:A PRIS/STYCK			
Ø mm	Längd	DJUP	PRIS
12	340	200	X
12	540	400	X
12	690	550	X
14	340	200	X
14,0	540	400	X
15	340	200	X
15	540	400	X
16	340	200	X
16	540	400	X
18	340	200	X
18,0	540	400	X
20	340	200	X
20	520	400	X
20	920	800	X
22	320	200	X
22	520	400	X
22	920	800	X
24	320	200	X
24	520	400	X
25	320	800	X
25	520	400	X
25	920	800	X
28	370	250	X
28	570	450	X
28	670	550	X
30	370	250	X
30	570	450	X
32	370	250	X
32	570	450	X
32	920	800	X
35	370	250	X
35	570	450	X
35	670	550	X
38	370	250	X
38	570	450	X
40	370	250	X
40	570	450	X
40	920	800	X

BESTÄLLNINGSEXEMPEL: 15900120160 - SDS+ 12X160/100

SWEBOLT AB

TEL 08 - 555 975 00 FAX 08 - 583 581 82

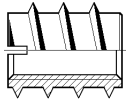
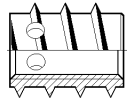
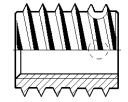
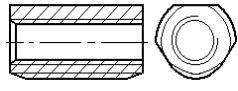
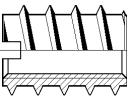
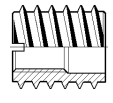
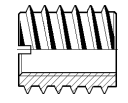
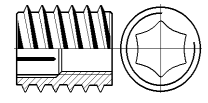
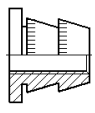
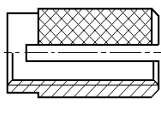
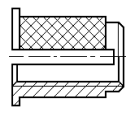
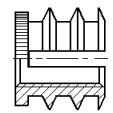
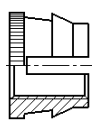
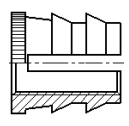
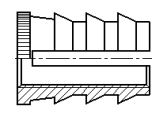
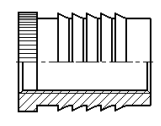
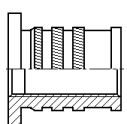
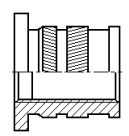
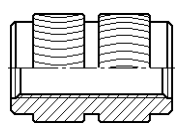
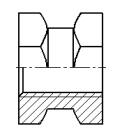
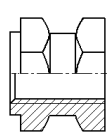
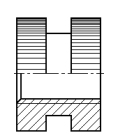
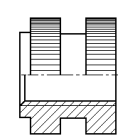
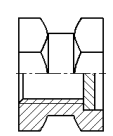
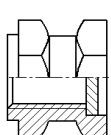
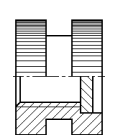
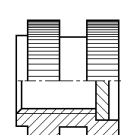
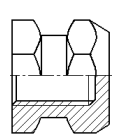
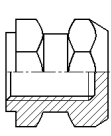
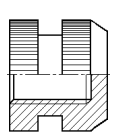
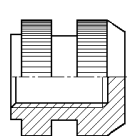
15:80

- 1 - 	- 2 - 	- 3 - 	- 4 - 
- 5 - 	- 6 - 	- 7 - 	- 8 - 
- 9 - 	- 10 - 	- 11 - 	- 12 - 
- 13 - 	- 14 - 	- 15 - 	- 16 - 
- 17 - 	- 18 - 	- 19 - 	- 20 - 
- 21 - 	- 22 - 	- 23 - 	- 24 - 
- 25 - 	- 26 - 	- 27 - 	- 28 - 
- 29 - 	- 30 - 	- 31 - 	- 32 - 

SWEBOLT AB

TEL. 08-584 909 60 FAX. 08-583 581 82

PRODUKTER I STÅL

1	116000	GI, GÄNGINSATS, SJÄLVG.				FZG	16:1
2	116002	GIS, SJÄLVG. m. SPÅNUTRYMME	KORT			FZG	16:1
2	116003	GIS, SJÄLVG. m. SPÅNUTRYMME	LÅNG			FZG	16:1
3	116005	GIS3, SJÄLVG. m. SPÅNUTRYMME	KORT			FZG	16:2
3	116006	GIS3, SJÄLVG. m. SPÅNUTRYMME	LÅNG			FZG	16:2
6	116012	IMS, TYP A, INSATSM. m. SPÅR	~7965A			FZB	16:2
7	116014	IMSF, TYP B, INV. FÖRSÄNK	~7965B			FZB	16:2
8	116016	IM6S, TYP SK, INSATSM. m. INSEX	~7965SK			FZB	16:3
9	116018	ISM, TYP IS, ISLAGSMUTTER				FZB	16:3
	116022	GB, GÄNGBUSSNING				FZB	16:3



MÄSSING

1	316000	GI, GÄNGINSATS, SJÄLVG.					16:1
4	316008	GIT, GÄNGINSATS FÖR TERMOPLAST					16:4
5	316010	GITP, GÄNGINSATS FÖR TRÄ OCH PLAST					16:4
10	316026	SGI, SPLITGÄNGINSATS FÖR PLAST					16:5
11	316028	SGIF, SPLITGÄNGINSATS MED FLÄNS					16:5
12	316030	SGIT, SPLITGÄNGINSATS FÖR TERMOPLAST					16:5
13	316032	STGIK, SPLITTRÄGÄNGINSATS, KORT					16:6
14	316034	STGIM, SPLITTRÄGÄNGINSATS, MEDEL					16:6
15	316036	STGIL, SPLITTRÄGÄNGINSATS, LÅNG					16:6
16	316040	PGIH, PRESSGÄNGINSATS m. HULLINGAR					16:6
17	316042	PGI, PRESSGÄNGINSATS FÖR TERMOPLAST					16:7
18	316044	PGIL, PRESSGÄNGINSATS FÖR ULTRALJUDSMONTAG					16:7
19	316046	PGIHL, PRESSGÄNGINSATS, TYP H-L					16:7
20	316060	IGA, INSATSG. f. PLAST, TYP A	16903A				16:8
21	316062	IGC, INSATSG. f. PLAST, TYP C	16903C				16:8
22	316064	IGB, INSATSG. f. PLAST, TYP B	16903B				16:9

<u>BILD</u>	<u>ART.GR.</u>	<u>BENÄMNING</u>	<u>DIN</u>	<u>ISO</u>	<u>KVAL</u>	<u>YTBEH</u>	<u>SIDA</u>
23	316066	IGD, INSATSG. f. PLAST, TYP D	16903D				16:9
24	316068	IGE, INSATSG. f. PLAST, TYP E	16903E				16:10
25	316070	IGG, INSATSG. f. PLAST, TYP G	16903G				16:10
26	316072	IGF, INSATSG. f. PLAST, TYP F	16903F				16:11
27	316074	IGH, INSATSG. f. PLAST, TYP H	16903H				16:11
28	316076	IGP, INSATSG. f. PLAST, TYP P	16903P				16:12
29	316078	IGR, INSATSG. f. PLAST, TYP R	16903R				16:12
30	316080	IGQ, INSATSG. f. PLAST, TYP Q	16903Q				16:13
31	316082	IGS, INSATSG. f. PLAST, TYP S	16903S				16:13

SWEBOLT AB

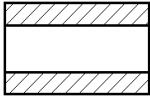
TEL. 08-584 909 60 FAX. 08-583 581 82

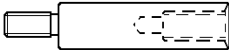
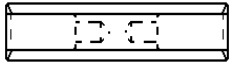
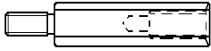
- 1 - 	- 2 - 	- 3 - 	- 4 - 
- 5 - 	- 6 -	- 7 -	- 8 -
- 9 -	- 10 -	- 11 -	- 12 -
- 13 -	- 14 -	- 15 -	- 16 -
- 17 -	- 18 -	- 19 -	- 20 -
- 21 -	- 22 -	- 23 -	- 24 -
- 25 -	- 26 -	- 27 -	- 28 -
- 29 -	- 30 -	- 31 -	- 32 -

SWEBOLT AB

TEL. 08-584 909 60 FAX. 08-583 581 82

PRODUKTER I STÅL

2	117003	DMRS, DISTANSMUTTER, RUND				FZG	17:3
3	117005	DSRS, DISTANSSKRUV				FZG	17:4
4	117008	DHS, DISTANSMUTTER, 6-KANT				FZG	17:1
5	117011	DSS, DISTANSSKRUV, 6-KANT				FZG	17:2

ROSTFRITT / SYRAFAST

1	217001	DHR, DISTANSHYLSA			A2		17:5
4	217007	DMRO, DISTANDMUTTER, 6-KANT			A2	OMAGNETISK	17:7
4	217008	DMR, DISTANSMUTTER, 6-KANT			A2		17:6
5	217011	DSR, DISTANSSKRUV, 6-KANT			A2		17:8
5	217012	DSRO, DISTANSSKRUV, 6-KANT			A2	OMEGNETISK	17:9

MÄSSING

1	317001	DHM, DISTANSHYLSA				FÖRNICKLAD	17:10
4	317008	DMM, DISTANS, 6-KANT				FÖRNICKLAD	17:11
5	317011	DSM, DISTANSSKRUV, 6-KANT				FÖRNICKLAD	17:12

POLYAMID

1	417000	DHPP, DISTANSHYLSA			POLYAMID PA 6.0		17:13
1	417020	DISTANS, RUND			NATUR		17:19
1	417021	DISTANS, RUND			VIT		17:19
1	417022	DISTANS, RUND			SVART		17:19
1	417023	DISTANS, RUND			RÖD		17:19
1	417024	DISTANS, RUND			GRÖN		17:19
2	417003	DMP, DISTANSMUTTER			POM-H		17:14
4	417009	DMNP, DISTANSMUTTER, 6-KANT			PPS SVART		17:15
4	417010	DMNP, DISTANSMUTTER, 6-KANT			POLYAMID PA 6.0 SVART		17:16
4	417008	DMNP, DISTANSMUTTER, 6-KANT			POM-4		17:17
5	417011	DSP, DISTANSSKRUV, 6-KANT			POLYAMID PA 6.0		17:18

GÄNGINSATSER

SATS MED INSATSGÄNGOR

10	17500	GÄNGINSATS M-GÄNGA	17:30
10	17507	GÄNGINSATS LÅS/"MID-GRIP" M-GÄNGA	17:33
10	17503	GÄNGINSATS UNC	17:31
10	17504	GÄNGINSATS UNF	17:31
10	17505	GÄNGINSATS BSW	17:32
10	17506	GÄNGINSATS BSF	17:32
10	17501	GÄNGINSATS BSP (G/R)	17:32
10	17510	M-GÄNGA SPEC.(FÖR "SPARK PLUG")	17:31

VERKTYG

11	17574	MONTERINGSVERKTYG ¼ FÄSTE	17:33
12	17571	HANDVERKTYG FÖR MONTERING	
17:40			
13	17572	BRYTVERKTYG	17:41
14	17573	URDRAGSVERKTYG FÖR GÄNGINSATSER	17:41

GÄNGTAPPAR FÖR INSATSGÄNGOR

15	17550	GÄNGTAPP METRISK RAK	17:3
16	17551	GÄNGTAPP METRISK SPÅNDR.	17:3
17	17552	GÄNGTAPP METRISK SPIRAL	17:3
18	17553	RULLGÄNGTAPP M-GÄNGA M-GÄNGA	17:3
15	17554	G-TAPP UNC RAK	17:3
15	17555	G-TAPP UNF RAK	17:3
15	17556	G-TAPP BSW-GÄNGA	17:3
15	17557	G-TAPP BSF-GÄNGA	17:3
20	17558	G-TAPP BSP(G) GÄNGA	17:3
21	17559	G-TAPP STI-"SPARK PLUG"	17:3
19	17597	G-TAPP STI-MASKIN GÄNGTAP	17:3

VERKSTADSPAKET FLERA DIMENSIONER PER PAKET

(BORR, GÄNGTAPP, GÄNGOR, MONTERINGSVERKTYG, BRYTVERKTYG)

22	17590	PAKET – M5-M12	17:37
22	17590	PAKET – M6-M14x1.25 NP	17:37
22	17590	PAKET – M6-M14x1.25 PT TÄNDSTIFT	17:37
22	17590	PAKET – ¼-½ UNC	17:37
22	17590	PAKET – ¼-½ UNF	17:37
22	17590	PAKET – ¼-½ BSW	17:38
22	17590	PAKET – ¼-½ BSF	17:38
22	17590	PAKET – M5-M12 MASKINMONTERING	17:38
22	17590	MONTERSATS/BUTIKSSTÄLL	17:39

REPARATIONSSATSER EN DIMENSION PER PAKET

(BORR, GÄNGTAPP, GÄNGOR, MONTERINGSVERKTYG, BRYTVERKTYG)

23	17580	REPARATIONSSATSER M-GÄNGA	17:34
23	17571	REPARATIONSSATS M-GÄNGA MASKIN	17:33
23	17581	REPARATIONSSATSER UNC	17:35
23	17582	REPARATIONSSATSER UNF	17:35
23	17583	REPARATIONSSATSER BSW	17:36
23	17584	REPARATIONSSATSER BSF	17:36
23	17585	REPARATIONSSATSER BSP (G/R)	17:36
23	17590	RAPARATIONSSATS TÄNDSTIFT	17:39

SWEBOLT AB

TEL. 08-584 909 60 FAX. 08-583 581 82

ARTIKELLISTA

2013-2014

V-COIL GÄNGINSATSER DIN 8140

Tolerans 6H ROSTFRI



C:A PRIS/100 ST							
NORMAL	FINGÅNG	1.0xD	1.5xD	2.0xD	2.5xD	3.0xD	FÖRP
	M2x0.4	X	X	X	X	X	100 ST
	M2.2x0.45	X	X	X	X	X	100 ST
	M2.5x0.45	X	X	X	X	X	100 ST
M3x0.5		X	X	X	X	X	100 ST
	M3.5x0.6	X	X	X	X	X	100 ST
M4x0.7		X	X	X	X	X	100 ST
M5x0.8		X	X	X	X	X	100 ST
M6x1		X	X	X	X	X	100 ST
	M7x1	X	X	X	X	X	100 ST
M8x1.25		X	X	X	X	X	100 ST
	M8x1	X	X	X	X	X	100 ST
	M9x1.25	X	X	X	X	X	100 ST
M10x1.5		X	X	X	X	X	100 ST
	M10x1.25	X	X	X	X	X	100 ST
	M10x1	X	X	X	X	X	100 ST
	M11x1.5	X	X	X	X	X	100 ST
M12x1.75		X	X	X	X	X	100 ST
	M12x1.5	X	X	X	X	X	100 ST
	M12x1.25	X	X	X	X	X	100 ST
	M12x1	X	X	X	X	X	100 ST
M14x2		X	X	X	X	X	50 ST
	M14x1.5	X	X	X	X	X	50 ST
	M14x1.25	X	X	X	X	X	50 ST
	M14x1.0	X	X	X	X	X	50 ST
M16x2		X	X	X	X	X	50 ST
	M16x1.5	X	X	X	X	X	50 ST
M18x2.5		X	X	X	X	X	25 ST
	M18x2.0	X	X	X	X	X	25 ST
	M18x1.5	X	X	X	X	X	25 ST
M20x2.5		X	X	X	X	X	25 ST
	M20x2.0	X	X	X	X	X	25 ST
	M20x1.5	X	X	X	X	X	25 ST
M22x2.5		X	X	X	X	X	10 ST
	M22x2.0	X	X	X	X	X	10 ST
	M22x1.5	X	X	X	X	X	10 ST
M24x3		X	X	X	X	X	10 ST
	M24x2.0	X	X	X	X	X	10 ST
	M24x1.5	X	X	X	X	X	10 ST
	M26x1.5		X				5 ST
M27x3.0			X				5 ST
	M27x2.0		X				5 ST
	M27x1.5		X				5 ST
M28x1.5			X				5 ST
M30x3.5			X				5 ST
	M30x2.0		X				5 ST
	M30x1.5		X				5 ST
M33x3.5			X				5 ST
	M33x2.0		X				5 ST
M36x4.0			X				5 ST
	M36x3.0		X				5 ST
	M36x2.0		X				5 ST
	M36x1.5		X				5 ST

BESTÄLLNINGSEXEMPEL: 1750008100080 - GI-1,0D M8x1,0

BESTÄLLNINGSEXEMPEL: 1750016200240 - GI-1,5D M16x2,0

SWEBOLT AB

TEL 08 - 555 975 00 FAX 08 - 583 581 82

17:30



ARTIKELLISTA

2013-2014

V-COIL GÄNGINSATSER DIN 8140 Tolerans 2B UNC - GÄNGA ROSTFRI

C:A PRIS/100 ST						
UNC	1.0xD	1.5xD	2.0xD	2.5xD	3.0xD	FÖRP
No 2 x 56	X	X	X	X	X	100 ST
No 4 x 40	X	X	X	X	X	100 ST
No 5 x 40	X	X	X	X	X	100 ST
No 6 x 32	X	X	X	X	X	100 ST
No 8 x 32	X	X	X	X	X	100 ST
No 10 x 24	X	X	X	X	X	100 ST
No 12 x 24	X	X	X	X	X	100 ST
1/4 x 20	X	X	X	X	X	100 ST
5/16 x 18	X	X	X	X	X	100 ST
3/8 x 16	X	X	X	X	X	100 ST
7/16 x 14	X	X	X	X	X	100 ST
1/2 x 13	X	X	X	X	X	100 ST
9/16 x 12	X	X	X	X	X	50 ST
5/8 x 11	X	X	X	X	X	50 ST
3/4 x 10	X	X	X	X	X	25 ST
7/8 x 9	X	X	X	X	X	10 ST
1" x 8	X	X	X	X	X	10 ST
1.1/8 x 9		X				5 ST
1.1/4 x 7		X				5 ST
1.3/8 x 7		X				5 ST
1.1/2 x 6		X				5 ST

BESTÄLLNINGSEXEMPEL: 17503

UNF - GÄNGA ROSTFRI

C:A PRIS/100 ST						
UNF	1.0xD	1.5xD	2.0xD	2.5xD	3.0xD	FÖRP
No 4 x 48	X	X	X	X	X	100 ST
No 6 x 40	X	X	X	X	X	100 ST
No 8 x 36	X	X	X	X	X	100 ST
No 10x 32	X	X	X	X	X	100 ST
1/4 x 28	X	X	X	X	X	100 ST
5/16 x 24	X	X	X	X	X	100 ST
3/8 x 24	X	X	X	X	X	100 ST
7/16 x 20	X	X	X	X	X	100 ST
1/2 x 20	X	X	X	X	X	100 ST
9/16 x 18	X	X	X	X	X	50 ST
5/8 x 18	X	X	X	X	X	50 ST
3/4 x 16	X	X	X	X	X	25 ST
7/8 x 14	X	X	X	X	X	10 ST
1" x 12	X	X	X	X	X	10 ST
1.1/8 x 12		X				5 ST
1.1/4 x 12		X				5 ST
1.3/8 x 12		X				5 ST
1.1/2 x 12		X				5 ST

BESTÄLLNINGSEXEMPEL: 17504

GÄNGINSATSER DIN 8140 för TÄNDSTIFT ROSTFRI

C:A PRIS/100 ST				
DIM	8,4 mm	12,4 mm	16,4 mm	FÖRP
M14x1,25	5600	5600	5600	50 ST

BESTÄLLNINGSEXEMPEL: 1751014125084 - GI-T M14x1,5x8,4

SWEBOLT AB

ARTIKELLISTA
2013-2014
V-COIL GÄNGINSATSER
DIN 8140
BSW - GÄNGA ROSTFRI



C:A PRIS/100 ST						
BSW	1.0xD	1.5xD	2.0xD	2.5xD	3.0xD	FÖRP
1/8 x 40	X	X	X	X	X	100 ST
3/16 x 24	X	X	X	X	X	100 ST
1/4 x 20	X	X	X	X	X	100 ST
5/16 x 18	X	X	X	X	X	100 ST
3/8 x 16	X	X	X	X	X	100 ST
7/16 x 14	X	X	X	X	X	100 ST
1/2 x 13	X	X	X	X	X	100 ST
9/16 x 12	X	X	X	X	X	50 ST
5/8 x 11	X	X	X	X	X	50 ST
3/4 x 10	X	X	X	X	X	25 ST
7/8 x 9	X	X	X	X	X	10 ST
1" x 8	X	X	X	X	X	10 ST

BESTÄLLNINGSEXEMPEL: 17505

BSF - GÄNGA ROSTFRI

C:A PRIS/100 ST						
BSF	1.0xD	1.5xD	2.0xD	2.5xD	3.0xD	FÖRP
3/16 x 24	X	X	X	X	X	100 ST
1/4 x 20	X	X	X	X	X	100 ST
5/16 x 18	X	X	X	X	X	100 ST
3/8 x 16	X	X	X	X	X	100 ST
7/16 x 14	X	X	X	X	X	100 ST
1/2 x 13	X	X	X	X	X	100 ST
9/16 x 12	X	X	X	X	X	50 ST
5/8 x 11	X	X	X	X	X	50 ST
3/4 x 10	X	X	X	X	X	25 ST
7/8 x 9	X	X	X	X	X	10 ST
1" x 8	X	X	X	X	X	10 ST

BESTÄLLNINGSEXEMPEL: 17506

G / R RÖRGÄNGA ROSTFRI

C:A PRIS/100 ST		
G / R	1.5xD	FÖRP
1/8 x 28	X	50 ST
1/4 x 19	X	50 ST
3/8 x 19	X	50 ST
1/2 x 14	X	50 ST
5/8 x 14	X	5 ST
3/4 x 14	X	5 ST
7/8 x 14	X	5 ST
1" x 11	X	5 ST

BESTÄLLNINGSEXEMPEL: 17501

SWEBOLT AB

TEL 08 - 555 975 00 FAX 08 - 583 581 82



ARTIKELLISTA

2013-2014

GÄNGINSATSER DIN 8140 Tolerans 6H ROSTFRI SJÄLVVLÅSANDE (RÖD)

C:A PRIS/100 ST				
GÄNGA	1.0xD	1.5xD	2.0xD	FÖRP
M3x0.5	X	X	X	100 ST
M4x0.75	X	X	X	100 ST
M5x0.8	X	X	X	100 ST
M6x1.0	X	X	X	100 ST
M8x1.25	X	X	X	100 ST
M10x1.5	X	X	X	100 ST
M12x1.75	X	X	X	100 ST
M14x2.0	X	X	X	50 ST
M16x2.0	X	X	X	50 ST

BESTÄLLNINGSEXEMPEL: 1750714200140 - GIL-1,0D M14x2,0 LÅS



V-COIL VERKTYG MONTERINGSVERKTYG FÖR MASKIN 1/4" SEXKANTSKAFT

C:A PRIS / STYCK					
M	LÄNGD	NYCKEL	SKAFT	PRIS	FÖRP
M3x0.5	46 mm	6 mm	1/4"	X	1 ST
M4x0.7	56	7	1/4"	X	1 ST
M5x0.8	62	8	1/4"	X	1 ST
M6x1.0	76	10	1/4"	X	1 ST
M8x1.25	85	12	1/4"	X	1 ST
M10x1.5	96	14	1/4"	X	1 ST
M12x1.75	107	16	1/4"	X	1 ST

BESTÄLLNINGSEXEMPEL: 1757506100 - M6x1,0 MASKIN



REPARATIONSSATS FÖR MASKIN M - GÄNGA ROSTFRI

C:A PRIS / STYCK					
GÄNGA	BORR	MONT VERKTYG	BRYT VERKTYG	GÄNGINSATS	PRIS
M3x0.5	3,2 mm	M3	No. 4	20 ST	X
M4x0.7	4,20	M4	No. 6	20	X
M5x0.8	5,20	M5	No. 8	20	X
M6x1.0	6,30	M6	No. 9	20	X
M8x12.5	8,30	M8	No. 11	20	X
M10x1.5	10,40	M10	No. 13	15	X
M12x1.75	12,40	M12	No. 15	10	X

BESTÄLLNINGSEXEMPEL: 1757108125 - GIM-SATS M8x1,25 MASKIN

SWEBOLT AB

TEL 08 - 555 975 00 FAX 08 - 583 581 82

ARTIKELLISTA

2013-2014

REPARATIONSSATSER V-COIL GÄNGINSATSER



Gänginsats längd = 1,5xD

C:A PRIS / STYCK					
TAPP	BORR	MONT VERKTYG	BRYT VERKTYG	GÄNGINSATS	PRIS
M2x0.4	2,1 mm	No. 2	No. 2	20 ST	X
M2.5x0.45	2,60	No. 3	No. 3	20	X
M3x0.5	3,20	No. 4	No. 4	20	X
M3.5x0.6	3,70	No. 5	No. 5	20	X
M4x0.7	4,20	No. 6	No. 6	20	X
M5x0.8	5,20	No. 8	No. 8	20	X
M6x1.0	6,30	No. 9	No. 9	20	X
M7x1.0	7,30	No. 10	No. 10	20	X
M8x1.25	8,30	No. 11	No. 11	20	X
M8x1.0	8,30	No. 11	No. 11	20	X
M9x1.25	9,30	No. 12	No. 12	15	X
M10x1.5	10,40	No. 13	No. 13	15	X
M10x1.25	10,30	No. 13	No. 13	15	X
M10x1.0	10,30	No. 13	No. 13	15	X
M11x1.5	11,40	No. 14	No. 14	10	X
M12x1.75	12,40	No. 15	No. 15	10	X
M12x1.5	12,40	No. 15	No. 15	10	X
M12x1.25	12,30	No. 15	No. 15	10	X
M12x1.0	12,30	No. 15	No. 15	10	X
M14x2.0		No. 16		10	X
M14x1.5		No. 16		10	X
M14x1.25		No. 17		10	X
M14x1.0		No. 17		10	X
M16x2.0		No. 18		10	X
M16x1.5		No. 18		10	X
M18x2.5		No. 20		5	X
M18x2.0		No. 22		5	X
M18x1.5		No. 22		5	X
M20x2.5		No. 21		5	X
M20x2.0		No. 21		5	X
M20x1.5		No. 21		5	X
M22x2.5		No. 22		5	X
M22x2.0		No. 22		5	X
M22x1.5		No. 22		5	X
M24x3.0		No. 23		5	X
M24x2.0		No. 23		5	X
M24x1.5		No. 23		5	X
M26x1.5				10 ST	X
M27x3.0				10	X
M27x2.0				10	X
M27x1.5				10	X
M28x1.5				10	X
M30x3.5				10	X
M30x2.0				10	X
M30x1.5				10	X
M33x3.5				10	X
M33x2.0				10	X
M36x4.0				10	X
M36x3.0				10	X
M36x2.0				10	X
M36x1.5				10	X

BESTÄLLNINGSEXEMPEL: 1758012175 - GI-SATS M12x1,75

SWEBOLT AB
TEL 08 - 584 909 60 FAX 08 - 583 581 82



ARTIKELLISTA

2013-2014

REPARATIONSSATSER

V-COIL UNC

Gånginsats längd = 1,5xD

C:A PRIS / STYCK					
UNC	BORR	MONT VERKTYG	BRYT VERKTYG	GÅNGINSATS	PRIS
No 2 x 56	2,4 mm	No. 2	No. 2	20 ST	X
No 4 x 40	3,10	No. 4	No. 4	20	X
No 5 x 40	3,40	No. 4	No. 4	20	X
No 6 x 32	3,80	No. 5	No. 5	20	X
No 8 x 32	4,40	No. 6	No. 6	20	X
No 10 x 24	5,20	No. 7	No. 7	20	X
No 12 x 24	5,80	No. 8	No. 8	20	X
1/4 x 20	6,70	No. 9	No. 9	20	X
5/16 x 18	8,30	No. 10	No. 10	20	X
3/8 x 16	9,90	No. 12	No. 12	15	X
7/16 x 14	11,60	No. 14	No. 14	10	X
1/2 x 13	13,00	No. 15	No. 15	10	X
9/16 x 12		No. 16		10	X
5/8 x 11		No. 18		10	X
3/4 x 10		No. 20		5	X
7/8 x 9		No. 22		5	X
1" x 8		No. 23		4	X
1.1/4 x 7		MONTERINGSVERKTYG INGÅR.		10 ST	X
1.1/4 x 7		1/2" FÄSTE + TRÄETUI + DUBBLA		10	X
1.3/8 x 6		GÄNGTAPPAR.		10	X
1.1/2 x 6				10	X

BESTÄLLNINGSEXEMPEL: 17581

V-COIL UNF

C:A PRIS / STYCK					
UNF	BORR	MONT VERKTYG	BRYT VERKTYG	GÅNGINSATS	PRIS
No 4 x 48	3,10	No. 4	No. 4	20 ST	X
No 6 x 40	3,80	No. 5	No. 5	20	X
No 8 x 36	4,40	No. 6	No. 6	20	X
No 10 x 32	5,20	No. 7	No. 7	20	X
1/4 x 28	6,70	No. 9	No. 9	20	X
5/16 x 24	8,30	No. 10	No. 10	20	X
3/8 x 24	9,90	No. 12	No. 12	15	X
7/16 x 20	11,60	No. 14	No. 14	10	X
1/2 x 20	13,00	No. 15	No. 15	10	X
9/16 x 18		No. 16		10	X
5/8 x 18		No. 18		10	X
3/4 x 16		No. 20		5	X
7/8 x 14		No. 22		5	X
1" x 12		No. 23		4	X
1.1/4 x 12		MONTERINGSVERKTYG INGÅR.		10 ST	X
1.1/4 x 12		1/2" FÄSTE + TRÄETUI + DUBBLA		10	X
1.3/8 x 12		GÄNGTAPPAR.		10	X
1.1/2 x 12				10	X

BESTÄLLNINGSEXEMPEL: 17582

SWEBOLT AB

TEL 08-555 975 00 FAX 08-583 581 82

ARTIKELLISTA

2013-2014

REPARATIONSSATSER

V-COIL BSW



Gånginsats längd = 1,5xD

C:A PRIS / STYCK					
BSW	BORR	MONT VERKTYG	BRYT VERKTYG	GÅNGINSATS	PRIS
1/8 x 40	3,4 mm	No. 4	No. 4	20 ST	X
3/16 x 24	5,00	No. 8	No. 8	20	X
1/4 x 20	6,70	No. 9	No. 9	20	X
5/16 x 18	8,30	No. 10	No. 11	20	X
3/8 x 16	9,90	No. 12	No. 12	15	X
7/16 x 14	11,50	No. 14	No. 14	10	X
1/2 x 12	13,00	No. 15	No. 15	10	X
9/16 x 12		No. 16		10	X
5/8 x 11		No. 18		10	X
3/4 x 10		No. 20		5	X
7/8 x 9		No. 22		5	X
1" x 8		No. 23		4	X

BESTÄLLNINGSEXEMPEL: 17583

V-COIL BSF

C:A PRIS / STYCK					
BSF	BORR	MONT VERKTYG	BRYT VERKTYG	GÅNGINSATS	PRIS
3/16 x 32	5,0 mm	No. 7	No. 6	20 ST	X
1/4 x 26	6,60	No. 9	No. 9	20	X
5/16 x 22	8,30	No. 11	No. 11	20	X
3/8 x 20	9,90	No. 13	No. 13	15	X
7/16 x 18	11,50	No. 14	No. 14	10	X
1/2 x 16	13,00	No. 15	No. 15	10	X
9/16 x 16		No. 16		10	X
5/8 x 14		No. 18		10	X
3/4 x 12		No. 20		5	X
7/8 x 11		No. 22		5	X
1" x 10		No. 23		4	X

BESTÄLLNINGSEXEMPEL: 17584

V-COIL G / R RÖRGÄNGA

C:A PRIS / STYCK					
R	BORR	MONT VERKTYG	BRYT VERKTYG	GÅNGINSATS	PRIS
1/8 x 28				10 ST	X
1/4 x 19				10	X
3/8 x 19				10	X
1/2 x 14		MONTERINGSVERKTYG INGÅR. 1/2" FÄSTE + TRÄETUI + DUBBLA GÄNGTAPPAR.		10	X
5/8 x 14				10	X
3/4 x 14				10	X
7/8 x 14				10	X
1" x 11				10	X

BESTÄLLNINGSEXEMPEL: 17585

SWEBOLT AB
 TEL 08-555 975 00 FAX 08-583 581 82



ARTIKELLISTA

2013-2014

MEKANIKERSATSER

V-COIL 1,5xD ROSTFRI

**SATSER MED BORR, GÄNGTAPP,
MONTERINGSVERKTYG OCH GÄNGINSATSER.**

M5 - M12

C:A PRIS / SATS				
M	BORR	MONT VERKTYG	BRYT VERKTYG	GÄNGINSATS
M5x0.8	5,2 mm	No. 8	No. 8	25 ST
M6x1.0	6,3	No. 9	No. 9	25
M8x1.25	8,3	No. 11	No. 11	25
M10x1.5	10,40	No. 13	No. 13	25
M12x1.75	12,40	No. 15	No. 15	10
ARTIKEL: 17590001				PRIS: X

M6 - M14x1,25

C:A PRIS / SATS				
M	BORR	MONT VERKTYG	BRYT VERKTYG	GÄNGINSATS
M6x1.0	6,3 mm	No. 9	No. 9	25 ST
M8x1.25	8,3	No. 11	No. 11	25
M10x1.5	10,40	No. 13	No. 13	25
M12x1.75	12,40	No. 15	No. 15	10
M14x1.25		No. 17		10
ARTIKEL: 17590002				PRIS: X

**M6 - M14x1,25
Tändstiftsats**

C:A PRIS / SATS				
M	BORR	MONT VERKTYG	BRYT VERKTYG	GÄNGINSATS
M6x1.0	6,3 mm	No. 9	No. 9	25 ST
M8x1.25	8,3	No. 11	No. 11	25
M10x1.5	10,40	No. 13	No. 13	25
M12x1.75	12,40	No. 15	No. 15	10
M14x1.25		No. 17		10
ARTIKEL: 17590003				PRIS: X

UNC 1/4 - 1/2

C:A PRIS / SATS				
UNC	BORR	MONT VERKTYG	BRYT VERKTYG	GÄNGINSATS
1/4 x 20	6,7 mm	No. 9	No. 9	25 ST
5/16 x 18	8,3	No. 10	No. 11	25
3/8 x 16	9,9	No. 12	No. 12	25
7/16 x 14	11,60	No. 14	No. 14	10
1/2 x 13	13,00	No. 15	No. 15	10
ARTIKEL: 17590004				PRIS: X

UNF 1/4 - 1/2

C:A PRIS / SATS				
UNF	BORR	MONT VERKTYG	BRYT VERKTYG	GÄNGINSATS
1/4 x 28	6,7 mm	No. 9	No. 9	25 ST
5/16 x 24	8,3	No. 10	No. 11	25
3/8 x 24	9,9	No. 13	No. 13	25
7/16 x 20	11,60	No. 14	No. 14	10
1/2 x 20	13,00	No. 15	No. 15	10
ARTIKEL: 17590005				PRIS: X

SWEBOLT AB

TEL 08-555 975 00 FAX 08-583 581 82

ARTIKELLISTA
2013-2014
MEKANIKERSATSER
V-COIL 1,5xD ROSTFRI



**SATSER MED BORR, GÄNGTAPP,
 MONTERINGSVERKTYG OCH GÄNGINSATSER.**

BSW 1/4 - 1/2

C:A PRIS / SATS				
BSW	BORR	MONT VERKTYG	BRYT VERKTYG	GÄNGINSATS
1/4 x 20	6,7 mm	No. 9	No. 9	25 ST
5/16 x 18	8,3	No. 10	No. 11	25
3/8 x 16	9,9	No. 12	No. 12	25
7/16 x 14	11,50	No. 14	No. 14	10
1/2 x 12	13,00	No. 15	No. 15	10
ARTIKEL: 17590006				PRIS: X

BSF 1/4 - 1/2

C:A PRIS / SATS				
BSW	BORR	MONT VERKTYG	BRYT VERKTYG	GÄNGINSATS
1/4 x 26	6,6 mm	No. 9	No. 9	25 ST
5/16 x 22	8,3	No. 11	No. 11	25
3/8 x 20	9,9	No. 12	No. 12	25
7/16 x 18	11,50	No. 14	No. 14	10
1/2 x 16	13,00	No. 15	No. 15	10
ARTIKEL: 17590007				PRIS: X

MEKANIKERSATSER
V-COIL 1,5xD ROSTFRI
MASKINGÄNGTAPP
MASKINMONTERINGSVERKTYG



M5 - M12



C:A PRIS / SATS				
M	BORR	MONT VERKTYG	BRYT VERKTYG	GÄNGINSATS
M5x0.8	5,2 mm	M5	No. 8	25 ST
M6x1.0	6,3	M6	No. 19	25
M8x1.25	8,3	M8	No. 11	25
M10x1.5	10,40	M10	No. 13	25
M12x1.75	12,40	M12	No. 15	10
ARTIKEL: 17590008				PRIS: X

SWEBOLT AB

TEL 08-555 975 00 FAX 08-583 581 82

ARTIKELLISTA

2013-2014

MONTERSATS / BUTIKSSATS REPARATIONSSATSER V-COIL 1,5xD ROSTFRI



INNEHÅLL:
KOMPLETTA REPARATIONSSATSER
MED OLIKA STORLEK. FRÅN M5
TILL M14. ÄVEN MEKANIKERSATS
M5-M12

C:A PRIS / SATS	
SATS	ANTAL
M5	5
M6	5
M8	5
M10	5
M12	5
M14x1.25	3
M5-M12	3
PRIS: X	

ARTIKEL: 17590009

REPARATIONSSATSER FÖR TÄNDSTIFT V-COIL 1,5xD ROSTFRI



C:A PRIS / SATS					
GÄNGA	MONT VERKTYG	GÄNGSATS LÄNGD			PRIS
		8,4 mm	12,4 mm	16,4 mm	
M14x1.25	No. 17	5 ST	5 ST	5 ST	X

ARTIKEL: 17590010 - REPARATIONSSATS TÄNDSTIFT M14x1,25

GÄNGTAPP TOLERANS 4H MED STYRNING



C:A PRIS / STYCK			
GÄNGA	B1	B2	PRIS
M6x1.0	6	7,3	X
M8x1.25	8	9,6	X
M10x1.5	10	11,8	X
M10x1.0	10	11,3	X
M12x1.25	12	13,6	X
M14x1.25	14	15,6	X
M18x1.5	18	20	X

BESTÄLLNINGSEXEMPEL:

SWEBOLT AB

TEL 08-555 975 00 FAX 08-583 581 82

ARTIKELLISTA
2013-2014
MONTERINGSVERKTYG



C:A PRIS / STYCK						
No.	M	UNC	UNF	BSW	BSF	PRIS
2	M2x0,4 M2,2x0,45	No. 2				X
3	M2,5x0,45					X
4	M3x0,5	No.4 No.5	No. 4	1/8		X
5	M3,5x0,6	No.6	No.6			X
6	M4x0,7	No.8	No. 8			X
7		No. 10		3/16		X
8	M5x0,8	No. 12	No. 10		3/16	X
9	M6x1,0	1/4	1/4	1/4	1/4	X
10	M7x1,0	5/16		5/16		X
11	M8x1,25 M8x1,0		5/16		5/16	X
12	M9x1,25 M9x1,0	3/8		3/8		X
13	M10x1,5 M10x1,25 M10x1,0		3/8		3/8	X
14	M11x1,5 M11x1,25	7/16	7/16	7/16	7/16	X
15	M12x1,75 M12x1,5 M12x1,25 M12x1,0	1/2	1/2	1/2	1/2	X
16	M14x2,0 M14x1,5	9/16	9/16	9/16	9/16	X
17	M14x1,25 M14x1,0					X
18	M16x2,0 M16x1,5	5/8	5/8	5/8	5/8	X
20	M18x2,5 M18x2,0 M18x1,5	3/4		3/4	3/4	X
21	M20x2,5 M20x2,0 M20x1,5		3/4			X
22	M22x2,5 M22x2,0 M22x1,5	7/8	7/8	7/8	7/8	X
23	M24x3,0 M24x2,0 M24x1,5	1"	1"	1"	1"	X

BESTÄLLNINGSEXEMPEL: 17571009 - MONTERINGSVERKTYG No.9

SWEBOLT AB
TEL 08 - 555 975 00 FAX 08 - 583 581 82

ARTIKELLISTA
2013-2014
BRYT VERKTYG



C:A PRIS / STYCK						
No.	M	UNC	UNF	BSW	BSF	PRIS
2	M2x0,4 M2,2x0,45	No. 2				X
3	M2,5x0,45					X
4	M3x0,5	No. 4	No. 4			X
5	M3,5x0,6	No. 6	No. 6			X
6	M4x0,7	No. 8 No. 10	No. 8		3/16	X
8	M5x0,8	No. 12	No. 10	3/16		X
9	M6x1,0	1/4	1/4	1/4	1/4	X
11	M7x1,0 M8x1,25 M8x1,0	5/16	5/16	5/16	5/16	X
12	M9x1,25 M9x1,0	3/8		3/8	3/8	X
13	M10x1,5 M10x1,25 M10x1,0		3/8			X
14	M11x1,5 M11x1,25	7/16	7/16	7/16	7/16	X
15	M12x1,75 M12x1,5 M12x1,25 M12x1,0	1/2	1/2	1/2	1/2	X

BESTÄLLNINGSEXEMPEL: 17572008 - BRYTVERKTYG No.8

DEMONTERINGSVERKTYG



C:A PRIS / STYCK						
No.	M	UNC	UNF	BSW	BSF	PRIS
2	M3-M10	3/16-3/8	3/16-3/8	3/16-3/8	3/16-3/8	X
3	M11-M24	3/8-1"	3/8-1"	3/8-1"	3/8-1"	X

BESTÄLLNINGSEXEMPEL: 17573003 - DEMONTERINGSVERKTYG No.3

SWEBOLT AB

TEL 08 - 555 975 00 FAX 08 - 583 581 82

ARTIKELLISTA

2013-2014

GÄNGTAPP Form D FÖR GÄNGINSATSER

C:A PRIS / STYCK				
		17550	17551	17552
NORMAL	FINGÅNG	RAK	SPÄND	SPIRAL
	M2x0.4	X		
	M2.2x0.45			
	M2.5x0.45	X		
M3x0.5		X	X	X
	M3.5x0.6			
M4x0.7		X	X	X
M5x0.8		X	X	X
M6x1		X	X	X
	M7x1	X		
M8x1.25		X	X	X
	M8x1	X		
M10x1.5		X	X	X
	M10x1.25	X		
	M10x1	X		
M12x1.75		X	X	X
	M12x1.5	X		
	M12x1.25	X		
	M12x1	X		
M14x2		X	X	X
	M14x1.5	X		
	M14x1.25	X		
	M14x1.0	X		
M16x2		X	X	X
	M16x1.5	X		
M18x2.5		X		
	M18x2.0	X		
	M18x1.5	X		
M20x2.5		X		
	M20x2.0	X		
	M20x1.5	X		
M22x2.5		X		
	M22x2.0	X		
	M22x1.5	X		
M24x3		X		
	M24x2.0	X		
	M24x1.5	X		

UNC

C:A PRIS / STYCK		
17554		
UNC	RAK	RAK
No 10x 24	X	X
No 12x 24	X	
1/4 x 20	X	X
5/16 x 18	X	X
3/8 x 16	X	X
7/16 x 14	X	X
1/2 x 13	X	X
9/16 x 12	X	X
5/8 x 11	X	X
3/4 x 10	X	X
7/8 x 9	X	X
1" x 8	X	X

UNF

C:A PRIS / STYCK		
17555		
UNF	RAK	RAK
No 10 x 32	X	X
No 12 x 24	X	
1/4 x 28	X	X
5/16 x 24	X	X
3/8 x 24	X	X
7/16 x 20	X	X
1/2 x 20	X	X
9/16 x 18	X	X
5/8 x 18	X	X
3/4 x 16	X	X
7/8 x 14	X	X
1" x 12	X	X

BESTÄLLNINGSEXEMPEL:
 BESTÄLLNINGSEXEMPEL:
 BESTÄLLNINGSEXEMPEL:

SWEBOLT AB

TEL 08 - 555 975 00 FAX 08 - 583 581 82

17:42

ARTIKELLISTA
2013-2014
GÄNGTAPP Form D FÖR GÄNGINSATSER

C:A PRIS / STYCK				
		17550	17551	17552
NORMAL	FINGÅNG	RAK	SPÄND	SPIRAL
	M2x0.4	X		
	M2.2x0.45			
	M2.5x0.45	X		
M3x0.5		X	X	X
	M3.5x0.6			
M4x0.7		X	X	X
M5x0.8		X	X	X
M6x1		X	X	X
	M7x1	X		
M8x1.25		X	X	X
	M8x1	X		
M10x1.5		X	X	X
	M10x1.25	X		
	M10x1	X		
M12x1.75		X	X	X
	M12x1.5	X		
	M12x1.25	X		
	M12x1	X		
M14x2		X	X	X
	M14x1.5	X		
	M14x1.25	X		
	M14x1.0	X		
M16x2		X	X	X
	M16x1.5	X		
M18x2.5		X		
	M18x2.0	X		
	M18x1.5	X		
M20x2.5		X		
	M20x2.0	X		
	M20x1.5	X		
M22x2.5		X		
	M22x2.0	X		
	M22x1.5	X		
M24x3		X		
	M24x2.0	X		
	M24x1.5	X		

UNC

C:A PRIS / STYCK		
17554		
UNC	RAK	RAK
No 10x 24	X	X
No 12x 24	X	
1/4 x 20	X	X
5/16 x 18	X	X
3/8 x 16	X	X
7/16 x 14	X	X
1/2 x 13	X	X
9/16 x 12	X	X
5/8 x 11	X	X
3/4 x 10	X	X
7/8 x 9	X	X
1" x 8	X	X

UNF

C:A PRIS / STYCK		
17555		
UNF	RAK	RAK
No 10 x 32	X	X
No 12 x 24	X	
1/4 x 28	X	X
5/16 x 24	X	X
3/8 x 24	X	X
7/16 x 20	X	X
1/2 x 20	X	X
9/16 x 18	X	X
5/8 x 18	X	X
3/4 x 16	X	X
7/8 x 14	X	X
1" x 12	X	X

BESTÄLLNINGSEXEMPEL:
 BESTÄLLNINGSEXEMPEL:
 BESTÄLLNINGSEXEMPEL:

SWEBOLT AB

TEL 08 - 555 975 00 FAX 08 - 583 581 82

ARTIKELLISTA

2013-2014

GÄNGTAPP Form D FÖR GÄNGINSATSER

C:A PRIS / STYCK				
		17550	17551	17552
NORMAL	FINGÅNG	RAK	SPÅND	SPIRAL
	M2x0.4	X		
	M2.2x0.45			
	M2.5x0.45	X		
M3x0.5		X	X	X
	M3.5x0.6			
M4x0.7		X	X	X
M5x0.8		X	X	X
M6x1		X	X	X
	M7x1	X		
M8x1.25		X	X	X
	M8x1	X		
M10x1.5		X	X	X
	M10x1.25	X		
	M10x1	X		
M12x1.75		X	X	X
	M12x1.5	X		
	M12x1.25	X		
	M12x1	X		
M14x2		X	X	X
	M14x1.5	X		
	M14x1.25	X		
	M14x1.0	X		
M16x2		X	X	X
	M16x1.5	X		
M18x2.5		X		
	M18x2.0	X		
	M18x1.5	X		
M20x2.5		X		
	M20x2.0	X		
	M20x1.5	X		
M22x2.5		X		
	M22x2.0	X		
	M22x1.5	X		
M24x3		X		
	M24x2.0	X		
	M24x1.5	X		

UNC

C:A PRIS / STYCK		
17554		
UNC	RAK	RAK
No 10x 24	X	X
No 12x 24	X	
1/4 x 20	X	X
5/16 x 18	X	X
3/8 x 16	X	X
7/16 x 14	X	X
1/2 x 13	X	X
9/16 x 12	X	X
5/8 x 11	X	X
3/4 x 10	X	X
7/8 x 9	X	X
1" x 8	X	X

UNF

C:A PRIS / STYCK		
17555		
UNF	RAK	RAK
No 10 x 32	X	X
No 12 x 24	X	
1/4 x 28	X	X
5/16 x 24	X	X
3/8 x 24	X	X
7/16 x 20	X	X
1/2 x 20	X	X
9/16 x 18	X	X
5/8 x 18	X	X
3/4 x 16	X	X
7/8 x 14	X	X
1" x 12	X	X











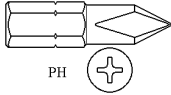

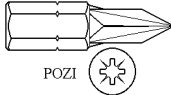

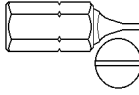
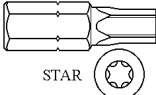

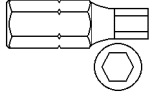
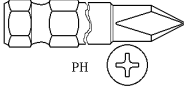

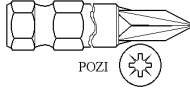

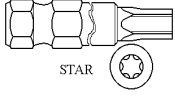

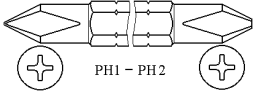

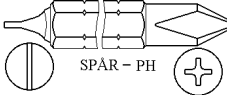

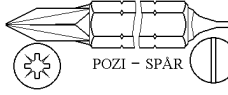

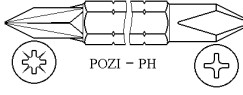

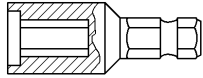
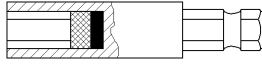
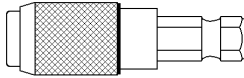

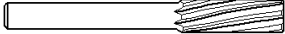

BESTÄLLNINGSEXEMPEL:

BESTÄLLNINGSEXEMPEL:

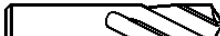
BESTÄLLNINGSEXEMPEL:

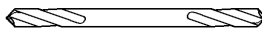
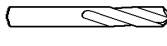
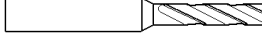
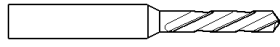

















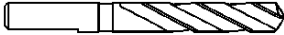
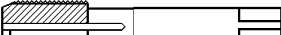
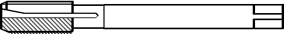
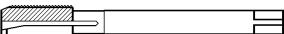

SWEBOLT AB

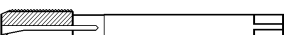
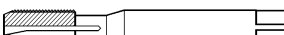
TEL 08 - 555 975 00 FAX 08 - 583 581 82

<p align="center">- 1 -</p>  <p align="center">PH </p>	<p align="center">- 2 -</p>  <p align="center">POZI </p>	<p align="center">- 3 -</p> 	<p align="center">- 4 -</p>  <p align="center">STAR </p>
<p align="center">- 5 -</p> 	<p align="center">- 6 -</p>  <p align="center">PH </p>	<p align="center">- 7 -</p>  <p align="center">POZI </p>	<p align="center">- 8 -</p>  <p align="center">STAR </p>
<p align="center">- 9 -</p>  <p align="center">PH1 - PH2  </p>	<p align="center">- 10 -</p>  <p align="center">SPAR - PH  </p>	<p align="center">- 11 -</p>  <p align="center">POZI - SPAR  </p>	<p align="center">- 12 -</p>  <p align="center">POZI - PH  </p>
<p align="center">- 13 -</p> 	<p align="center">- 14 -</p> 	<p align="center">- 15 -</p> 	<p align="center">- 16 -</p> 
<p align="center">- 17 -</p> 	<p align="center">- 18 -</p> 	<p align="center">- 19 -</p> 	<p align="center">- 20 -</p> 
<p align="center">- 21 -</p> 	<p align="center">- 22 -</p> 	<p align="center">- 23 -</p> 	<p align="center">- 24 -</p> 
<p align="center">- 25 -</p> 	<p align="center">- 26 -</p> 	<p align="center">- 27 -</p> 	<p align="center">- 28 -</p> 
<p align="center">- 29 -</p> 	<p align="center">- 30 -</p> 	<p align="center">- 31 -</p> 	<p align="center">- 32 -</p> 

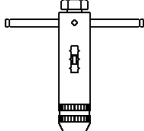
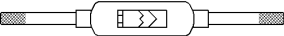

SWEBOLT AB

TEL. 08-584 909 60 FAX. 08-583 581 82

- 33 - 	- 34 - 	- 35 - 	- 36 - 
- 37 - 	- 38 - 	- 39 - 	- 40 - 
- 41 - 	- 42 - 	- 43 - 	- 44 - 
- 45 - 	- 46 - 	- 47 - 	- 48 - 
- 49 - 	- 50 - 	- 51 - 	- 52 - 
- 53 - 	- 54 - Borrbitssats	- 55 - 	- 56 - Gängbitssats
- 57 - Borr- & Gängbitssats	- 58 - Kombisats	- 59 - 	- 60 - 
- 61 - 	- 62 - 	- 63 - Gängtappsats	- 64 - Gängtapp & snittsats

SWEBOLT AB

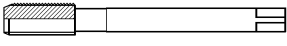
TEL. 08-584 909 60 FAX. 08-583 581 82

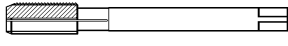
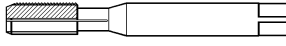
- 65 - 	- 66 - 	- 67 - 	- 68 - 
- 69 -	- 70 -	- 71 -	- 72 -
- 73 -	- 74 -	- 75 -	- 76 -
- 77 -	- 78 -	- 79 -	- 80 -
- 81 -	- 82 -	- 83 -	- 84 -
- 85 -	- 86 -	- 87 -	- 88 -
- 89 -	- 90 -	- 91 -	- 92 -
- 93 -	- 94 -	- 95 -	- 96 -

SWEBOLT AB

TEL. 08-584 909 60 FAX. 08-583 581 82

VERKTYG

1	68000	BITS, PH, PHILLIPS, HÄRDAD, GRÅ		18:1
1	68010	BITS, PH, PHILLIPS, EXTRA HÅRD		18:1
2	68020	BITS, POZI, HÄRDAD GRÅ		18:1
2	68030	BITS, POZI, EXTRA HÅRD		18:1
3	68040	BITS, MEJSEL, HÄRDAD, GRÅ		18:4
3	68050	BITS, MEJSEL, EXTRA HÅRD		18:4
4	68070	BITS, STAR, HÄRDAD, GRÅ		18:1
5	68080	BITS, INVÄNDIG 6-KANT, HÄRDAD, GRÅ		18:1
6	68090	MASKINSKRUVMEJSEL L70mm, PH, HÄRDAD		18:3
7	68100	MASKINSKRUVMEJSEL L70mm, POZI, HÄRDAD		18:3
8	68110	MASKINSKRUVMEJSEL L70mm, STAR, HÄRDAD		18:3
6	68130	MASKINSKRUVMEJSEL L90mm, PH, HÄRDAD		18:3
7	68140	MASKINSKRUVMEJSEL L90mm, POZI, HÄRDAD		18:3
8	68150	MASKINSKRUVMEJSEL L90mm, STAR, HÄRDAD		18:3
6	68180	MASKINSKRUVMEJSEL L150mm, PH, HÄRDAD		18:3
7	68190	MASKINSKRUVMEJSEL L150mm, POZI, HÄRDAD		18:3
8	68200	MASKINSKRUVMEJSEL L150mm, STAR, HÄRDAD		18:3
8	68220	MASKINSKRUVMEJSEL SKAFT 6/8mm, STAR, HÄRDAD		18:3
9-12		DUBBELSIDIG BITS PH-POZI-STAR, HÄRDAD		18:5
13	68250	MUTTERHYLSA, MAGNETISK 42mm		18:6
13	68260	MUTTERHYLSA, MAGNETISK 65mm		18:6
13	28251	MUTTERHYLSA, OMAGNETISK		18:6
14	68280	BITSHÅLLARE, MAGNETISK		18:6
15		BITSHÅLLARE, MAGNETISK m. SNABBCHUCK		18:6

BORR

19	60099	BORR, VALSAD HSS	338N	18:19
19	60100	BORR, SLIPAD HSS	338N	18:18
19	60101	BORR, HSS-E COBOLT	338N	18:20
19	60102	BORR, HSS-TiN	338N	18:21
19	60103	BORR, HSS-E COBOLT TiN	338N	18:22
21	60104	BORR, LÅNG SPIRAL HSS	338H	18:23
22	60105	BORR, TÄT SPIRAL HSS	338W	18:24
22	60106	BORR, HSS HSSE COBOLT	338S	18:25
22	60107	BORR, HSSE COBOLT-TiN	338S	18:26
23	60108	BORR, HSS, STABIL	338TLS1000	18:27
23	60109	BORR, HSS TiN, STABIL	338TLS1000	18:28
23	60110	BORR, HSS-E COBOLT	338TLS1000	18:29
23	60111	BORR, HSS-E COBOLT-TiN	338TLS1000	18:30
23	60112	BORR, HSCo-TiCN	338TLS1000	18:31
23	60113	BORR, HSCo-TiAlN	338TLS1000	18:32
20	60114	BORR, HSS VÄNSTER	338N	18:33

SWEBOLT AB

TEL. 08-584 909 60 FAX. 08-583 581 82

BILD	ART.GR.	BENÄMNING	DIN	SIDA
24	60116	BORR HSCO, SPIRAL	1897S	18:37
24	60117	BORR HSS, VALSAD	1897N	18:38
28	60118	BORR FÖRSÄNKT, HSCo	1899S	18:39
29	60119	BORR FÖRSÄNKT HSCo, VÄNSTER	1899N	18:40
25	60122	BORR, HSS, VÄNSTER	1897N	18:34
24	60123	BORR, HSS	1897N	18:35
24	60124	BORR, HSS-TiN		18:36
26	60125	POPNITSBORR DUBBEL, VALSAD OCH SLIPAD		18:17
33	60129	BORR MK VALSAD HSS	345N	18:60
33	60130	BORR MK SLIPAD HSS	345N	18:61
33	60131	BORR, MK, HSS TiN	345N	18:62
33	60132	BORR, MK, HSCo	345N	18:63
33	60133	BORR, MK, HSCo TiN	345N	18:64
33	60134	BORR, MK, HSCo TICN	345N	18:65
33	60135	BORR, MK, HSCo TIAIN	345N	18:66
30	60140	BORR , CYL SKAFT HSS	339N	18:41
30	60141	BORR , CYL SKAFT HSS-TiN	339N	18:42
30	60142	BORR , CYL SKAFT HSCo	339N	18:43
19	60143	LÅNG BORR, HSS VALSAD	340N	18:44
19	60144	LÅNG BORR, HSS SLIPAD	340N	18:45
19	60145	LÅNG BORR, HSS-TiN	340N	18:46
19	60146	LÅNG BORR, HSCo	340N	18:47
22	60147	LÅNG BORR, HSCo, SPIRAL	340S	18:48
23	60148	LÅNG BORR, HSS	340TLS500	18:49
23	60149	LÅNG BORR, HSCo	340TLS1000	18:50
23	60150	LÅNG BORR, HSS	340TLS	18:51
23	60151	LÅNG BORR, HSS-TiN	340TLS	18:52
31	60152	DJUPHÅLSBORR, HSS, A-C	1869N	18:53
32	60153	DJUPHÅLSBORR, HSS TLS 500	1869TLS	18:55
32	60154	DJUPHÅLSBORR, HSS TLS 1000	1869TLS	18:57
32	60155	DJUPHÅLSBORR, HSCo TLS 1000	1869TLS	18:59
33	60160	BORR MK, HSS	341N	18:69
33	60161	BORR MK, HSS-TiN	341N	18:70
33	60162	BORR MK, HSCo	341N	18:71
34	60163	BORR MK, HSS	341TLS1000	18:72
34	60164	BORR MK, HSS-TiN	341TLS1000	18:73
33	60165	BORR MK, MED KYLKANAL HSCo	341N	18:74
33	60166	BORR MK, MED KYLKANAL RADIEL HSCo	341N	18:75
33	60167	BORR MK, MED KYLKANAL RADIEL HSCo	341	18:76
34	60168	BORR MK, MED KYLKANAL GENOMG. HSCo TLS1000	341	18:77
34	60169	BORR MK, MED KYLKANAL RADIEL HSCo TLS1000	341	18:78
34	60170	BORR MK, MED KYLKANAL RADIEL HSCo TLS 1000	341BK	18:79
33	60171	BORR MK, DJUPHÅLSBORR LÄNGD 1 HSS	1870N-A	18:80
33	60172	BORR MK, DJUPHÅLSBORR LÄNGD 2 HSS	1870N-B	18:81
33	60173	BORR MK, DJUPHÅLSBORR TLS HSS	1870N-A	18:82

SWEBOLT AB

TEL. 08-584 909 60 FAX. 08-583 581 82

BILD	ART.GR.	BENÄMNING	DIN	SIDA
33	60174	BORR MK, DJUPHÅLSBORR TLS HSS	1870N-B	18:83
33	60175	BORR MK, DJUPHÅLSBORR TLS HSCo	1870N-A	18:84
33	60176	BORR MK, DJUPHÅLSBORR TLS HSCo	1870N-B	18:84
35	60189	TAPPBORR 90° (STEBBORR), FIN	8374	18:85
35	60190	TAPPBORR 90° (STEBBORR), MEDER	8374	18:85
35	60191	TAPPBORR 90° (STEBBORR)	8378	18:85
36	60192	TAPPBORR 180° (STEBBORR)	8376	18:86
36	60193	TAPPBORR 180° (STEBBORR)	8376	18:86
37	60194	TAPPBORR MK 90° (STEBBORR)	8375	18:87
37	60195	TAPPBORR MK 90° (STEBBORR)	8379	18:87
38	60196	TAPPBORR MK 180° (STEBBORR)	8377	18:88
39	60200	CENTRUMBORR 60° Form A HSS	333	18:89
40	60201	CENTRUMBORR 60°/120° Form B HSS	333	18:89
40	60202	CENTRUMBORR 60°/120° Form R HSS	333	18:89
39	60203	CENTRUMBORR 60° Form A HSS	333	18:90
40	60204	CENTRUMBORR 60°/120° Form B HSS	333	18:90
40	60205	CENTRUMBORR 60°/120° Form R HSS	333	18:90
24	60210	HÅRDMETALLBORR VHM-K10/K20	6539	18:91
19	60211	HÅRDMETTALLBORR VHM K10/K20	338	18:92
19	60212	HÅRDMETALLBORR NC-BORR Form A 90° VHM K10/K20	338	18:93
		HÅRDMETALLBORR NC-BORR Form B 120° VHM K10/K20	338	18:93
30	60213	HÅRDMETALLBESTYCKAD K10/K20	8037	18:94
33	60214	HÅRDMETALLBESTYCKAD MK K10/K20	8041	18:95
41	60218	PLÅTBORR HSS		18:96
41	60219	PLÅTBORR HSCo		18:96
24	60220	NC-BORR 90° HSCo		18:97
24	60221	NC-BORR 120° HSCo		18:97
24	60222	NC-BORR 90° HSCo-TiN		18:97
24	60223	NC-BORR 120° HSCo-TiN		18:97
42	60226	CNC-BORR borrhjup 3xd HSCo MED KYLKANAL		18:98
42	60227	CNC-BORR borrhjup 3xd HSCo-TiN MED KYLKANAL		18:98
42	60228	CNC-BORR borrhjup 5xd HSCo MED KYLKANAL		18:99
42	60229	CNC-BORR borrhjup 5xd HSCo-TiN MED KYLKANAL		18:99
		RULLGÄNGTAPP METRISK GÄNGA		
66	65320	RULLGÄNGTAPP BLANK	371	18:141
66	65321	RULLGÄNGTAPP VAP	371	18:141
66	65322	RULLGÄNGTAPP TIN	371	18:141
65	65326	RULLGÄNGTAPP BLANK	376	18:141
65	65327	RULLGÄNGTAPP VAP	376	18:141
65	65328	RULLGÄNGTAPP TIN	376	18:141

SWEBOLT AB

TEL. 08-584 909 60 FAX. 08-583 581 82

BILD	ART.GR.	BENÄMNING	DIN	SIDA
68	65330	RULLGÄNGTAPP med smörjspår BLANK	371	18:142
68	65331	RULLGÄNGTAPP med smörjspår VAP	371	18:142
68	65332	RULLGÄNGTAPP med smörjspår TIN	371	18:142
67	65336	RULLGÄNGTAPP med smörjspår BLANK	376	18:142
67	65337	RULLGÄNGTAPP med smörjspår VAP	376	18:142
67	65338	RULLGÄNGTAPP med smörjspår TIN	376	18:142
HANDGÄNGTAPP METRISK GÄNGA				
43	65000	HANDGÄNGTAPP 6H M-GÄNGA Serie I-II-III HSS-G	352	18:151
43	65001	HANDGÄNGTAPP 6H M-GÄNGA koniskt utförande HSS-G I-II-III	352	18:152
43	65002	HANDGÄNGTAPP 6H M-GÄNGA Serie I-III HSS-G fingänga	2181	18:153
43		HANDGÄNGTAPP 6H M-GÄNGA Serie I-III	2181	18:153
43	65003	HANDGÄNGTAPP UNC I-II-III	352	18:155
43	65004	HANDGÄNGTAPP UNF I-II-III	352	18:155
43	65005	HANDGÄNGTAPP BSW	352	18:156
43	65006	HANDGÄNGTAPP BSF	352	18:156
43	65007	HANDGÄNGTAPP G	352	18:157
43	65008	HANDGÄNGTAPP PG	352	18:157
43	65009	HANDGÄNGTAPP TR	352	18:158
43	65010	HANDGÄNGTAPP M-GÄNGA, I-II-III HSS-E (Cobolt)	352	18:159
43	65011	HANDGÄNGTAPP M-FINGÄNGA, I o III HSS-E, Cobolt	352	18:159
43	65012	HANDGÄNGTAPP M-GÄNGA, I-II-III HSS-G VÄNSTER	352	18:160
43		HANDGÄNGTAPP M-FINGÄNGA, I o III HSS-G VÄNSTER	2181	18:160
45	65050	SPÅNDRIVANDE MASKINGÄNGTAPP HSS-E 6H	352	18:161
47	65051	SPIRALGÄNGTAPP 35° HSS-E 6H	352	18:161
47	65052	INTERRUPT G-TAPP HSS-E 6H	352	18:161
43	65053	GÄNGTAPP FINGÄNGA HSS-G	2181	18:162
43	65054	GÄNGTAPP HSS-G UNC-GÄNGA		18:162
43	65055	GÄNGTAPP HSS-G UNF-GÄNGA		18:163
43	65056	GÄNGTAPP HSS-G BSW-GÄNGA		18:164
43	65057	GÄNGTAPP BSP(G)-GÄNGA		18:164
43	65058	GÄNGTAPP PG-GÄNGA		18:165
43	65059	GÄNGTAPP NPT-GÄNGA		18:165
51	65060	KOMBITAPP BORR+GÄNGA 6H HSS-E		18:166
44	65120	MASKING-TAPP HSS-E Form C	371	18:167
43	65121	MASKING-TAPP HSS-E Form C	376	18:167
46	65122	SPÅNDRIVANDE G-TAPP HSS-E	371	18:168
45	65123	SPÅNDRIVANDE G-TAPP HSS-E	376	18:168
48	65124	SPIRALGÄNGTAPP 15° HSS-E	371	18:169
47	65125	SPIRALGÄNGTAPP 15° HSS-E	376	18:169
47	65126	SPIRALGÄNGTAPP 35° HSS-E	371	18:170
48	65127	SPIRALGÄNGTAPP 35° HSS-E	376	18:170

SWEBOLT AB

TEL. 08-584 909 60 FAX. 08-583 581 82

BILD	ART.GR.	BENÄMNING	DIN	SIDA
49	65128	INTERRUPT GÄNGTAPP HSS-E	371	18:171
50	65129	INTERRUPT GÄNGTAPP HSS-E	376	18:171
44	65130	MASKINTAPP VÄNSTER HSS-E	371	18:172
43	65131	MASKINTAPP VÄNSTER HSS-E	376	18:172
SPÅNDRIVANDE MASKINGÄNGTAPP				
46	65132	SPÅNDRIVANDE HSS-E TiN	371	18:173
45	65133	SPÅNDRIVANDE HSS-E TiN	376	18:173
48	65134	SPIRALGÄNGTAPP HSS-E TiN	371	18:173
47	65135	SPIRALGÄNGTAPP HSS-E TiN	376	18:173
44	65140	MASKINGÄNGTAPP FINGÄNGA HSS-E 6H	374	18:174
45	65141	SPÅNDRIVANDE FINGÄNGA HSS-E 6H	374	18:175
47	65142	SPÅNDRIVANDE-TAPP UNC-GÄNGA HSS-E	~371	18:176
48	65143	SPÅNDRIVANDE-TAPP UNC-GÄNGA HSS-E	~376	18:176
47	65144	SPÅNDRIVANDE-TAPP UNF-GÄNGA HSS-E	~371	18:176
48	65145	SPÅNDRIVANDE-TAPP UNF-GÄNGA HSS-E	~376	18:176
47	65146	SPÅNDRIVANDE-TAPP BSW-GÄNGA HSS-E	~371	18:176
48	65147	SPÅNDRIVANDE-TAPP BSW-GÄNGA HSS-E	~376	18:176
SPIRAN MASKINGÄNGTAPP				
47	65148	SPIRALGÄNGTAPP UNC-GÄNGA HSS-E	~371	18:177
48	65149	SPIRALGÄNGTAPP UNC-GÄNGA HSS-E	~376	18:177
48	65150	SPIRALGÄNGTAPP UNF-GÄNGA HSS-E	~371	18:177
47	65151	SPIRALGÄNGTAPP UNF-GÄNGA HSS-E	~376	18:177
48	65152	SPIRALGÄNGTAPP BSW-GÄNGA HSS-E	~371	18:177
47	65153	SPIRALGÄNGTAPP BSW-GÄNGA HSS-E	~376	18:177
43	65154	MASKINTAPP G (BSP) HSS-E	5156	18:178
45	65155	SPÅNDRIVANDE G (BSP) HSS-E	5156	18:178
45	65156	SPIRALGÄNGTAPP G (BSP) HSS-E	5156	18:178
MASKINGÄNGTAPP "RING"				
47	65160	SPIRALGÄNGTAPP 39° HSS-E GRÖN RING	371	18:181
48	65161	SPIRALGÄNGTAPP 39° HSS-E GRÖN RING	376	18:181
46	65162	SPÅNDRIVANDE HSS-E GRÖN RING	371	18:181
45	65163	SPÅNDRIVANDE HSS-E GRÖN RING	376	18:181
47	65164	SPIRALGÄNGTAPP 39° HSS-E BLÅ RING	371	18:182
48	65165	SPIRALGÄNGTAPP 39° HSS-E BLÅ RING	376	18:182
46	65166	SPÅNDRIVANDE HSS-E BLÅ RING	371	18:182
45	65167	SPÅNDRIVANDE HSS-E BLÅ RING	376	18:182
47	65168	SPIRALGÄNGTAPP 39° HSS-E VIT RING	371/376	18:183
46	65170	SPÅNDRIVANDE HSS-E VIT RING	371/376	18:183
46	65172	SPÅNDRIVANDE HSS-E SVART RING	371/376	18:184
46	65173	SPÅNDRIVANDE HSS-E RÖD RING	371	18:184
46	65180	SPÅNDRIVANDE HSS-G	ISO 529	18:185
48	65181	SPIRALGÄNGTAPP HSS-G	ISO 529	18:185
50	65182	INTERRUPT HSS-G	ISO 529	18:185

SWEBOLT AB

TEL. 08-584 909 60 FAX. 08-583 581 82

BILD	ART.GR.	BENÄMNING	DIN	SIDA
GÄNGSNITT				
52	65200	GÄNGSNITT HSS 69	223	18:186
52	65201	GÄNGSNITT HSS 69 runt 25mm		18:186
52	65202	GÄNGSNITT FINGÄNGA HSS 69	223	18:187
52	65203	GÄNGSNITT UNC-gänga HSS	~223	18:188
52	65204	GÄNGSNITT UNF-gänga HSS	~223	18:188
52	65205	GÄNGSNITT BSW-gänga HSS	223	18:189
52	65206	GÄNGSNITT BSF-gänga HSS	223	18:189
52	65207	GÄNGSNITT G (BSP) HSS	5158	18:190
52	65208	GÄNGSNITT PG HSS	40434	18:190
52	65209	GÄNGSNITT NPT HSS	223	18:190
52	65210	GÄNGSNITT M-gänga VÄNSTER	223	18:191
52	65211	GÄNGSNITT M-fingänga VÄNSTER	223	18:191
GÄNGBITS – BORRBITS - KOMBIBITS				
53	65250	BORRBITS HSS-G ¼ SKAFT		18:200
54	65251	BORRBITSSATS HSS-G PLASTASK		18:200
55	65252	GÄNGBITS HSS-G ¼ SKAFT		18:201
56	65253	GÄNGBITSSATS HSS-G PLASTASK		18:201
57	65254	BORR och GÄNGBITSSATS M3-M10		18:201
58	65255	KOMBISATS M3-M10 ¼ FÄSTE BORR-GÄNG-FAS		18:202
59	65256	KOMBIBITS		18:202
63	65300	GÄNGTAPPSATS I PLASTBOX		18:206
64	65301	GÄNGTAPP och SNITTSATS M3-M20 INKL HÅLLARE		18:206
64	65302	GÄNGTAPP och SNITTSATS M3-M12 INKL HÅLLARE		18:207
64	65303	GÄNGTAPP och SNITTSATS ¼ - ¾ INKL HÅLLARE		18:207
HANDVERKTYG				
60	65280	GÄNGTAPPHÅLLARE Nr 1-4		18:205
61	65281	STÄLLBART SVANGJÄRN		18:205
62	65282	GÄNGKLOPPA		18:205
RULLGÄNGTAPP METRISK GÄNGA				
66	65400	RULLGÄNGTAPP HSS-E 6HX Typ FC	371	18:221
66	65401	RULLGÄNGTAPP HSS-E 6HX Typ FC-TiN	371	18:221
66	65402	RULLGÄNGTAPP HSS-E 6HX Typ FC-TiCN	371	18:221
66	65403	RULLGÄNGTAPP HSS-E 6HX Typ FC-XY	371	18:221
68	65404	RULLGÄNGTAPP HSS-E 6HX Typ FCS	371	18:221
67	65405	RULLGÄNGTAPP HSS-E 6HX Typ FCS-TiN	371	18:221
67	65406	RULLGÄNGTAPP HSS-E 6HX Typ FCS-TiCN	371	18:221
67	65407	RULLGÄNGTAPP HSS-E 6HX Typ FCS-XY	371	18:221
67	65408	RULLGÄNGTAPP HSS-E 6HX Typ FCSIK	371	18:221
67	65409	RULLGÄNGTAPP HSS-E 6HX Typ FCSIK-TiN	371	18:221
67	65410	RULLGÄNGTAPP HSS-E 6HX Typ FCSIK-TiCN	371	18:221
67	65411	RULLGÄNGTAPP HSS-E 6HX Typ FCSIK-XY	371	18:221

SWEBOLT AB

TEL. 08-584 909 60 FAX. 08-583 581 82

BILD	ART.GR.	BENÄMNING	DIN	SIDA
67	65412	RULLGÄNGTAPP FINGÄNGA HSS-E 6HX Typ FC	371	18:222
66	65413	RULLGÄNGTAPP FINGÄNGA HSS-E 6HX Typ FC-TiN	371	18:222
66	65414	RULLGÄNGTAPP FINGÄNGA HSS-E 6HX Typ FC-TICN	371	18:222
66	65415	RULLGÄNGTAPP FINGÄNGA HSS-E 6HX Typ FC-XY	371	18:222
66	65416	RULLGÄNGTAPP FINGÄNGA HSS-E 6HX Typ FCS	371	18:222
68	65417	RULLGÄNGTAPP FINGÄNGA HSS-E 6HX Typ FCS-TiN	371	18:222
68	65418	RULLGÄNGTAPP FINGÄNGA HSS-E 6HX Typ FCS-TICN	371	18:222
68	65419	RULLGÄNGTAPP FINGÄNGA HSS-E 6HX Typ FCS-XY	371	18:222
68	65420	RULLGÄNGTAPP FINGÄNGA HSS-E 6HX Typ FCSIK	371	18:222
68	65421	RULLGÄNGTAPP FINGÄNGA HSS-E 6HX Typ FCSIK-TiN	371	18:222
68	65422	RULLGÄNGTAPP FINGÄNGA HSS-E 6HX Typ FCSIK-TICN	371	18:222
68	65423	RULLGÄNGTAPP FINGÄNGA HSS-E 6HX Typ FCSIK-XY	371	18:222
65	65424	RULLGÄNGTAPP HSS-E 6HX Typ FC	376	18:223
65	65425	RULLGÄNGTAPP HSS-E 6HX Typ FC-TiN	376	18:223
65	65426	RULLGÄNGTAPP HSS-E 6HX Typ FC-TICN	376	18:223
65	65427	RULLGÄNGTAPP HSS-E 6HX Typ FC-XY	376	18:223
67	65428	RULLGÄNGTAPP HSS-E 6HX Typ FCS	376	18:223
67	65429	RULLGÄNGTAPP HSS-E 6HX Typ FCS-TiN	376	18:223
67	65430	RULLGÄNGTAPP HSS-E 6HX Typ FCS-TICN	376	18:223
67	65431	RULLGÄNGTAPP HSS-E 6HX Typ FCS-XY	376	18:223
67	65432	RULLGÄNGTAPP HSS-E 6HX Typ FCSIK	376	18:223
67	65433	RULLGÄNGTAPP HSS-E 6HX Typ FCSIK-TiN	376	18:223
67	65434	RULLGÄNGTAPP HSS-E 6HX Typ FCSIK-TICN	376	18:223
67	65435	RULLGÄNGTAPP HSS-E 6HX Typ FCSIK-XY	376	18:223
65	65436	RULLGÄNGTAPP FINGÄNGA HSS-E 6HX Typ FC	374	18:224
65	65437	RULLGÄNGTAPP FINGÄNGA HSS-E 6HX Typ FC-TiN	374	18:224
65	65438	RULLGÄNGTAPP FINGÄNGA HSS-E 6HX Typ FC-TICN	374	18:224
65	65439	RULLGÄNGTAPP FINGÄNGA HSS-E 6HX Typ FC-XY	374	18:224
67	65440	RULLGÄNGTAPP FINGÄNGA HSS-E 6HX Typ FCS	374	18:224
67	65441	RULLGÄNGTAPP FINGÄNGA HSS-E 6HX Typ FCS-TiN	374	18:224
67	65442	RULLGÄNGTAPP FINGÄNGA HSS-E 6HX Typ FCS-TICN	374	18:224
67	65443	RULLGÄNGTAPP FINGÄNGA HSS-E 6HX Typ FCS-XY	374	18:224
67	65444	RULLGÄNGTAPP FINGÄNGA HSS-E 6HX Typ FCSIK	374	18:224
67	65445	RULLGÄNGTAPP FINGÄNGA HSS-E 6HX Typ FCSIK-TiN	374	18:224
67	65446	RULLGÄNGTAPP FINGÄNGA HSS-E 6HX Typ FCSIK-TICN	374	18:224
67	65447	RULLGÄNGTAPP FINGÄNGA HSS-E 6HX Typ FCSIK-XY	374	18:224
43	65448	M-GÄNGTAPP HSS-E 6H Typ CN	352	18:225
43	65449	M-GÄNGTAPP HSS-E 6H Typ CN-TiN	352	18:225
43	65450	M-GÄNGTAPP HSS-E 6G Typ CN	352	18:225
45	65451	M-GÄNGTAPP HSS-E 6G Typ CN-TiN	352	18:225
SPÅNDRIVANDE METRISK MASKINGÄNGTAPP				
45	65452	SPÅNDRIVANDE HSS-E 6H Typ BN	352	18:226
45	65453	SPÅNDRIVANDE HSS-E 6H Typ BN-VAP	352	18:226
45	65454	SPÅNDRIVANDE HSS-E 6H Typ BN-TiN	352	18:226
45	65455	SPÅNDRIVANDE HSS-E 6H Typ BVA	352	18:226
45	65456	SPÅNDRIVANDE HSS-E 6H Typ BVA-VAP	352	18:226
45	65457	SPÅNDRIVANDE HSS-E 6H Typ BVA-TiN	352	18:226
45	65458	SPÅNDRIVANDE HSS-E 6G Typ BN	352	18:227
45	65459	SPÅNDRIVANDE HSS-E 6G Typ BN-VAP	352	18:227

SWEBOLT AB

TEL. 08-584 909 60 FAX. 08-583 581 82

<u>BILD</u>	<u>ART.GR.</u>	<u>BENÄMNING</u>	<u>DIN</u>	<u>SIDA</u>
45	65460	SPÅNDRIVANDE HSS-E 6G Typ BN-TiN	352	18:227
45	65461	SPÅNDRIVANDE HSS-E 6HX Typ BVA	352	18:228
45	65462	SPÅNDRIVANDE HSS-E 6HX Typ BVA-VAP	352	18:228
45	65463	SPÅNDRIVANDE HSS-E 6HX Typ BVA-TiN	352	18:228
SPIRAL METRISK MASKINGÄNGTAPP				
47	65464	SPIRAL HSSE 40° 6H Typ R40N	352	18:229
47	65465	SPIRAL HSSE 40° 6H Typ R40N-VAP	352	18:229
47	65466	SPIRAL HSSE 40° 6H Typ R40N-TiN	352	18:229
47	65467	SPIRAL HSSE 40° 6H Typ R40N-TiCN	352	18:229
47	65468	SPIRAL HSSE 40° 6G Typ R40N	352	18:230
47	65469	SPIRAL HSSE 40° 6G Typ R40N-VAP	352	18:230
47	65470	SPIRAL HSSE 40° 6G Typ R40N-TiN	352	18:230
47	65471	SPIRAL HSSE 40° 6G Typ R40N-TiCN	352	18:230
METRISK MASKINGÄNGTAPP				
44	65472	M-MASKINGÄNGTAPP HSS-E Rak 6H Typ CN	371	18:231
44	65473	M-MASKINGÄNGTAPP HSS-E Rak 6H Typ CN-TiN	371	18:231
44	65474	M-MASKINGÄNGTAPP HSS-E Rak 6H Typ CAI	371	18:231
44	65475	M-MASKINGÄNGTAPP HSS-E Rak 6H Typ CAI-TiN	371	18:231
44	65476	M-MASKINGÄNGTAPP HSS-E Rak 6G Typ CN	371	18:232
44	65477	M-MASKINGÄNGTAPP HSS-E Rak 6G Typ CAI	371	18:232
44	65478	M-MASKINGÄNGTAPP HSS-E Rak 6G Typ CAI-TiN	371	18:232
44	65479	M-MASKINGÄNGTAPP HSS-E Rak 6H Typ CGG	371	18:233
44	65480	M-MASKINGÄNGTAPP HSS-E Rak 6H Typ CGG-NIT	371	18:233
44	65481	M-MASKINGÄNGTAPP HSS-E Rak 6H Typ CGG-TiN	371	18:233
44	65482	M-MASKINGÄNGTAPP HSS-E Rak 6H Typ EMS	371	18:233
44	65483	M-MASKINGÄNGTAPP HSS-E Rak 6H Typ CN	376	18:234
44	65484	M-MASKINGÄNGTAPP HSS-E Rak 6H Typ CN-TiN	376	18:234
44	65485	M-MASKINGÄNGTAPP HSS-E Rak 6H Typ CAI	376	18:234
44	65486	M-MASKINGÄNGTAPP HSS-E Rak 6H Typ CAI-TiN	376	18:234
44	65487	M-MASKINGÄNGTAPP HSS-E Rak 6G Typ CN	376	18:235
44	65488	M-MASKINGÄNGTAPP HSS-E Rak 6G Typ CN-TiN	376	18:235
44	65489	M-MASKINGÄNGTAPP HSS-E Rak 6HX Typ CGG	376	18:236
44	65490	M-MASKINGÄNGTAPP HSS-E Rak 6HX Typ CGG-NIT	376	18:236
44	65491	M-MASKINGÄNGTAPP HSS-E Rak 6HX Typ CGG-TiN	376	18:236
44	65492	M-MASKINGÄNGTAPP HSS-E Rak 6HX Typ EMS	376	18:236
SPÅNDRIVANDE METRISK MASKINGÄNGTAPP				
46	65493	SPÅNDRIVANDE HSSE 6H Typ BN	371	18:237
46	65494	SPÅNDRIVANDE HSSE 6H Typ BN-VAP	371	18:237
46	65495	SPÅNDRIVANDE HSSE 6H Typ BN-TiN	371	18:237
46	65496	SPÅNDRIVANDE HSSE 6H Typ BAI	371	18:237
46	65497	SPÅNDRIVANDE HSSE 6H Typ BAI-TiN	371	18:237
46	65498	SPÅNDRIVANDE HSSE 6H Typ BAI-TiCN	371	18:237
46	65499	SPÅNDRIVANDE HSSE 6H Typ BLN	371	18:237
46	65500	SPÅNDRIVANDE HSSE 6H Typ BLN-TiN	371	18:237
46	65501	SPÅNDRIVANDE HSSE 6H Typ BLNS	371	18:237

SWEBOLT AB

TEL. 08-584 909 60 FAX. 08-583 581 82

BILD	ART.GR.	BENÄMNING	DIN	SIDA
46	65502	SPÅNDRIVANDE HSSE 6H Typ BLNS-TiN	371	18:237
46	65503	SPÅNDRIVANDE HSSE 6H Typ BVA	371	18:237
46	65504	SPÅNDRIVANDE HSSE 6H Typ BVA-VAP	371	18:237
46	65505	SPÅNDRIVANDE HSSE 6H Typ BVA-TiN	371	18:237
46	65506	SPÅNDRIVANDE HSSE 6H Typ BH	371	18:237
46	65507	SPÅNDRIVANDE HSSE 6H Typ BH-TIC	371	18:237
46	65508	SPÅNDRIVANDE HSSE 6G Typ BN	371	18:238
46	65509	SPÅNDRIVANDE HSSE 6G Typ BN-VAP	371	18:238
46	65510	SPÅNDRIVANDE HSSE 6G Typ BN-TIP	371	18:238
46	65511	SPÅNDRIVANDE HSSE 6G Typ BH	371	18:238
46	65512	SPÅNDRIVANDE HSSE 6G Typ BH-TICN	371	18:238
46	65513	SPÅNDRIVANDE HSSE 6HX Typ BVA	371	18:239
46	65514	SPÅNDRIVANDE HSSE 6HX Typ BVA-VAP	371	18:239
46	65515	SPÅNDRIVANDE HSSE 6HX Typ BVA-TiN	371	18:239
46	65516	SPÅNDRIVANDE HSSE 6HX Typ BCNIK	371	18:239
46	65517	SPÅNDRIVANDE HSSE 6HX Typ BCNIK-TICN	371	18:239
45	65518	SPÅNDRIVANDE HSS-E 6H Typ BN	376	18:240
45	65519	SPÅNDRIVANDE HSS-E 6H Typ BN-VAP	376	18:240
45	65520	SPÅNDRIVANDE HSS-E 6H Typ BN-TiN	376	18:240
45	65521	SPÅNDRIVANDE HSS-E 6H Typ BAI	376	18:240
45	65522	SPÅNDRIVANDE HSS-E 6H Typ BAI-TiN	376	18:240
45	65523	SPÅNDRIVANDE HSS-E 6H Typ BAI-TICN	376	18:240
45	65524	SPÅNDRIVANDE HSS-E 6H Typ BVA	376	18:241
45	65525	SPÅNDRIVANDE HSS-E 6H Typ BVA-VAP	376	18:241
45	65526	SPÅNDRIVANDE HSS-E 6H Typ BVA-TiN	376	18:241
45	65528	SPÅNDRIVANDE HSS-E 6H Typ BLN	376	18:241
45	65529	SPÅNDRIVANDE HSS-E 6H Typ BLN-TiN	376	18:241
45	65530	SPÅNDRIVANDE HSS-E 6H Typ BLNS	376	18:241
45	65531	SPÅNDRIVANDE HSS-E 6H Typ BLNS-TiN	376	18:241
45	65532	SPÅNDRIVANDE HSS-E 6H Typ BH	376	18:241
45	65533	SPÅNDRIVANDE HSS-E 6H Typ BH-TICN	376	18:241
45	65534	SPÅNDRIVANDE HSS-E 6G Typ BN	376	18:242
45	65535	SPÅNDRIVANDE HSS-E 6G Typ BN-VAP	376	18:242
45	65536	SPÅNDRIVANDE HSS-E 6G Typ BN-TiN	376	18:242
45	65537	SPÅNDRIVANDE HSS-E 6G Typ BH	376	18:242
45	65538	SPÅNDRIVANDE HSS-E 6G Typ BH-TICN	376	18:242
45	65539	SPÅNDRIVANDE HSS-E 6HX Typ BVA	376	18:243
45	65540	SPÅNDRIVANDE HSS-E 6HX Typ BVA-VAP	376	18:243
45	65541	SPÅNDRIVANDE HSS-E 6HX Typ BVA-TiN	376	18:243
45	65542	SPÅNDRIVANDE HSS-E 6HX Typ BCNIK	376	18:243
45	65543	SPÅNDRIVANDE HSS-E 6HX Typ BCNIK-TICN	376	18:243
		SPIRAL METRISK MASKINGÄNGTAPP		
48	65554	SPIRAL 40° HSS-E 6H Typ R40N	371	18:244
48	65555	SPIRAL 40° HSS-E 6H Typ R40N-VAP	371	18:244
48	65556	SPIRAL 40° HSS-E 6H Typ R40N-TiN	371	18:244
48	65557	SPIRAL 40° HSS-E 6H Typ R40N-TICN	371	18:244
48	65558	SPIRAL 40° HSS-E 6H Typ R40NT	371	18:244
48	65559	SPIRAL 40° HSS-E 6H Typ R40NT-VAP	371	18:244

SWEBOLT AB

TEL. 08-584 909 60 FAX. 08-583 581 82

BILD	ART.GR.	BENÄMNING	DIN	SIDA
48	65560	SPIRAL 40° HSS-E 6H Typ R40NT-TiN	371	18:244
48	65561	SPIRAL 40° HSS-E 6H Typ R40NT-TiCN	371	18:244
48	65562	SPIRAL 40° HSS-E 6H Typ R40VA	371	8:245
48	65563	SPIRAL 40° HSS-E 6H Typ R40VA-VAP	371	18:245
48	65564	SPIRAL 40° HSS-E 6H Typ R40VA-TiCN	371	18:245
48	65565	SPIRAL 40° HSS-E 6H Typ R40VA-XY	371	18:245
48	65566	SPIRAL 40° HSS-E 6H Typ R40VAT	371	18:245
48	65567	SPIRAL 40° HSS-E 6H Typ R40VAT-VAP	371	18:245
48	65568	SPIRAL 40° HSS-E 6H Typ R40VAT-TiCN	371	18:245
48	65569	SPIRAL 40° HSS-E 6H Typ R40VAT-XY	371	18:245
48	65570	SPIRAL 40° HSS-E 6G Typ R40N	371	18:246
48	65571	SPIRAL 40° HSS-E 6G Typ R40N-VAP	371	18:246
48	65572	SPIRAL 40° HSS-E 6G Typ R40N-TiN	371	18:246
48	65573	SPIRAL 40° HSS-E 6G Typ R40N-TiCN	371	18:246
48	65574	SPIRAL 40° HSS-E 6G Typ R40NT	371	18:246
48	65575	SPIRAL 40° HSS-E 6G Typ R40NT-VAP	371	18:246
48	65576	SPIRAL 40° HSS-E 6G Typ R40NT-TiN	371	18:246
48	65577	SPIRAL 40° HSS-E 6G Typ R40NT-TiCN	371	18:246
48	65578	SPIRAL 40° HSS-E 6HX Typ R40VA	371	18:247
48	65579	SPIRAL 40° HSS-E 6HX Typ R40VA-VAP	371	18:247
48	65580	SPIRAL 40° HSS-E 6HX Typ R40VA-TiCN	371	18:247
48	65581	SPIRAL 40° HSS-E 6HX Typ R40VA-XY	371	18:247
48	65582	SPIRAL 40° HSS-E 6HX Typ R40VAT	371	18:247
48	65583	SPIRAL 40° HSS-E 6HX Typ R40VAT-VAP	371	18:247
48	65584	SPIRAL 40° HSS-E 6HX Typ R40VAT-TiCN	371	18:247
48	65585	SPIRAL 40° HSS-E 6HX Typ R40VAT-XY	371	18:247
48	65586	SPIRAL 40° HSS-E 6HX Typ R40GIK-TiCN	371	18:247
48	65587	SPIRAL 40° HSS-E 6HX Typ R40GIK-XY	371	18:247
48	65588	SPIRAL 45° HSS-E 6H Typ R45AI	371	18:247
48	65589	SPIRAL 45° HSS-E 6H Typ R45AI-NIT	371	18:247
48	65590	SPIRAL 45° HSS-E 6H Typ R45AI-TiCN	371	18:247
47	65591	SPIRAL 40° HSS-E 6H Typ R40N	376	18:248
47	65592	SPIRAL 40° HSS-E 6H Typ R40N-VAP	376	18:248
47	65593	SPIRAL 40° HSS-E 6H Typ R40N-TiN	376	18:248
47	65594	SPIRAL 40° HSS-E 6H Typ R40N-TiCN	376	18:248
47	65595	SPIRAL 40° HSS-E 6H Typ R40NT	376	18:248
47	65596	SPIRAL 40° HSS-E 6H Typ R40NT-VAP	376	18:248
47	65597	SPIRAL 40° HSS-E 6H Typ R40NT-TiN	376	18:248
47	65598	SPIRAL 40° HSS-E 6H Typ R40NT-TiCN	376	18:248
47	65599	SPIRAL 40° HSS-E 6H Typ R40VA	376	18:249
47	65600	SPIRAL 40° HSS-E 6H Typ R40VA-VAP	376	18:249
47	65601	SPIRAL 40° HSS-E 6H Typ R40VA-TiCN	376	18:249
47	65602	SPIRAL 40° HSS-E 6H Typ R40VA-XY	376	18:249
47	65603	SPIRAL 40° HSS-E 6H Typ R40VAT	376	18:249
47	65604	SPIRAL 40° HSS-E 6H Typ R40VAT-VAP	376	18:249
47	65605	SPIRAL 40° HSS-E 6H Typ R40VAT-TiCN	376	18:249
47	65606	SPIRAL 40° HSS-E 6H Typ R40VAT-XY	376	18:249
47	65607	SPIRAL 40° HSS-E 6G Typ R40N	376	18:250

SWEBOLT AB

TEL. 08-584 909 60 FAX. 08-583 581 82

BILD	ART.GR.	BENÄMNING	DIN	SIDA
47	65608	SPIRAL 40° HSS-E 6G Typ R40N-VAP	376	18:250
47	65609	SPIRAL 40° HSS-E 6G Typ R40N-TiN	376	18:250
47	65610	SPIRAL 40° HSS-E 6G Typ R40N-TICN	376	18:250
47	65611	SPIRAL 40° HSS-E 6G Typ R40NT	376	18:250
47	65612	SPIRAL 40° HSS-E 6G Typ R40NT-VAP	376	18:250
47	65613	SPIRAL 40° HSS-E 6G Typ R40NT-TiN	376	18:250
47	65614	SPIRAL 40° HSS-E 6G Typ R40NT-TICN	376	18:250
47	65615	SPIRAL 40° HSS-E 6HX Typ R40VA	376	18:251
47	65616	SPIRAL 40° HSS-E 6HX Typ R40VA-VAP	376	18:251
47	65617	SPIRAL 40° HSS-E 6HX Typ R40VA-TICN	376	18:251
47	65618	SPIRAL 40° HSS-E 6HX Typ R40VA-XY	376	18:251
47	65619	SPIRAL 40° HSS-E 6HX Typ R40VAT	376	18:251
47	65620	SPIRAL 40° HSS-E 6HX Typ R40VAT-VAP	376	18:251
47	65621	SPIRAL 40° HSS-E 6HX Typ R40VAT-TICN	376	18:251
47	65622	SPIRAL 40° HSS-E 6HX Typ R40VAT-XY	376	18:251
47	65623	SPIRAL 40° HSS-E 6HX Typ R40GIK-TICN	376	18:251
47	65624	SPIRAL 40° HSS-E 6HX Typ R40GIK-XY	376	18:251
47	65625	SPIRAL 45° HSS-E 6HX Typ R45A1	376	18:252
47	65626	SPIRAL 45° HSS-E 6HX Typ R45AL-NIT	376	18:252
47	65627	SPIRAL 45° HSS-E 6HX Typ R45AL-TICN	376	18:252
47	65628	SPIRAL 15° HSS-E 6H Typ R15N	371	18:253
47	65629	SPIRAL 15° HSS-E 6H Typ R15N-VAP	371	18:253
47	65630	SPIRAL 15° HSS-E 6H Typ R15N-TiN	371	18:253
47	65631	SPIRAL 15° HSS-E 6H Typ R15H	371	18:253
47	65632	SPIRAL 15° HSS-E 6H Typ R15H-TICN	371	18:253
47	65633	SPIRAL 15° HSS-E 6HX Typ R15GG	371	18:254
47	65634	SPIRAL 15° HSS-E 6HX Typ R15GG-NIT	371	18:254
47	65635	SPIRAL 15° HSS-E 6HX Typ R15GG-TiN	371	18:254
47	65636	SPIRAL 15° HSS-E VÄNSTER 6H Typ L15N	371	18:254
47	65637	SPIRAL 15° HSS-E VÄNSTER 6H Typ L15N-VAP	371	18:254
47	65638	SPIRAL 15° HSS-E 6H Typ R15N	376	18:255
47	65639	SPIRAL 15° HSS-E 6H Typ R15N-VAP	376	18:255
47	65640	SPIRAL 15° HSS-E 6H Typ R15N-TiN	376	18:255
47	65641	SPIRAL 15° HSS-E 6H Typ R15H	376	18:255
47	65642	SPIRAL 15° HSS-E 6H Typ R15H-TICN	376	18:255
47	65643	SPIRAL 15° HSS-E 6HX Typ R15GG	376	18:256
47	65644	SPIRAL 15° HSS-E 6HX Typ R15GG-NIT	376	18:256
47	65645	SPIRAL 15° HSS-E 6HX Typ R15GG-TiN	376	18:256
47	65646	SPIRAL 15° HSS-E VÄNSTER 6H Typ L15N	376	18:256
47	65647	SPIRAL 15° HSS-E VÄNSTER 6H Typ L15N-VAD	376	18:256
INTERRUPT METRISK GÄNGTAPP				
50	65648	M-INTERRUPT GÄNGTAPP HSS-E 6H Typ CVAAZ	371	18:257
50	65649	M-INTERRUPT GÄNGTAPP HSS-E 6H Typ CVAAZ-TiN	371	18:257
50	65650	M-INTERRUPT spåndrivande HSS-E 6H Typ BVAAZ	371	18:258
50	65651	M-INTERRUPT spåndrivande HSS-E 6H Typ BVAAZ-VAP	371	18:258

SWEBOLT AB

TEL. 08-584 909 60 FAX. 08-583 581 82

BILD	ART.GR.	BENÄMNING	DIN	SIDA
50	65652	M-INTERRUPT spåndrivande HSS-E 6H Typ BVAAZ-TiN	371	18:258
50	65653	M-INTERRUPT 6-TAPP HSS-E 6GX Typ EprAZ	371	18:259
50	65654	M-INTERRUPT 6-TAPP HSS-E 6GX Typ EprAZ-XY	371	18:259
50	65655	M-INTERRUPT 6-TAPP HSS-E 6HX Typ CVAAZ	371	18:260
50	65656	M-INTERRUPT 6-TAPP HSS-E 6HX Typ CVAAZ-TiN	371	18:260
50	65657	M-INTERRUPT spåndrivande HSS-E 6HX Typ BVAAZ	371	18:261
50	65658	M-INTERRUPT spåndrivande HSS-E 6HX Typ BVAAZ-VAP	371	18:261
50	65659	M-INTERRUPT spåndrivande HSS-E 6HX Typ BVAAZ-TiN	371	18:261
49	65660	M-INTERRUPT G-TAPP HSS-E 6H Typ CVAAZ	376	18:262
49	65661	M-INTERRUPT G-TAPP HSS-E 6H Typ CVAAZ-TiN	376	18:262
49	65662	M-INTERRUPT spåndrivande HSS-E 6H Typ BVAAZ	376	18:263
49	65663	M-INTERRUPT spåndrivande HSS-E 6H Typ BVAAZ-VAP	376	18:263
49	65664	M-INTERRUPT spåndrivande HSS-E 6H Typ BVAAZ-TiN	376	18:263
49	65665	M-INTERRUPT G-TAPP HSS-E 6HX Typ CVAAZ	376	18:264
49	65666	M-INTERRUPT G-TAPP HSS-E 6HX Typ CVAAZ-TiN	376	18:264
49	65667	M-INTERRUPT spåndrivande HSS-E 6HX Typ BVAAZ	376	18:265
49	65668	M-INTERRUPT spåndrivande HSS-E 6HX Typ BVAAZ-VAP	376	18:265
49	65669	M-INTERRUPT spåndrivande HSS-E 6HX Typ BVAAZ-TiN	376	18:265
49	65670	M-INTERRUPT G-TAPP HSS-E 6GX Typ EPrAZ	376	18:266
49	65671	M-INTERRUPT G-TAPP HSS-E 6GX Typ EprAZ-XY	376	18:266
SPÅNDRIVANDE FINGÄNGA MASKINGÄNGTAPP				
45	65672	FINGÄNGA SPÅNDRIVANDE 6H Typ BLN	376	18:267
45	65673	FINGÄNGA SPÅNDRIVANDE 6H Typ BLN-TiN	376	18:267
45	65674	FINGÄNGA SPÅNDRIVANDE 6H Typ BLNS	376	18:267
45	65675	FINGÄNGA SPÅNDRIVANDE 6H Typ BLNS-TiN	376	18:267
SPIRAL FINGÄNGA MASKINGÄNGTAPP				
45	65676	FINGÄNGA SPIRAL 40° 6H Typ R40N	376	18:268
47	65677	FINGÄNGA SPIRAL 40° 6H Typ R40N-VAP	376	18:268
47	65678	FINGÄNGA SPIRAL 40° 6H Typ R40N-TiN	376	18:268
47	65679	FINGÄNGA SPIRAL 40° 6H Typ R40N-TICN	376	18:268
47	65680	FINGÄNGA SPIRAL 40° 6H Typ R40NT	376	18:268
47	65681	FINGÄNGA SPIRAL 40° 6H Typ R40NT-VAP	376	18:268
47	65682	FINGÄNGA SPIRAL 40° 6H Typ R40NT-TiN	376	18:268
47	65683	FINGÄNGA SPIRAL 40° 6H Typ R40NT-TICN	376	18:268
48	65684	FINGÄNGA SPIRAL 40° HSS-E 6H Typ R40VA	371	18:268
48	65685	FINGÄNGA SPIRAL 40° HSS-E 6H Typ R40VA-VAP	371	18:268
48	65686	FINGÄNGA SPIRAL 40° HSS-E 6H Typ R40VA-TICN	371	18:268
48	65687	FINGÄNGA SPIRAL 40° HSS-E 6H Typ R40VA-XY	371	18:268
48	65688	FINGÄNGA SPIRAL 40° HSS-E 6H Typ R40VAT	371	18:268
48	65689	FINGÄNGA SPIRAL 40° HSS-E 6H Typ R40VAT-VAP	371	18:268
48	65690	FINGÄNGA SPIRAL 40° HSS-E 6H Typ R40VAT-TICN	371	18:268
48	65691	FINGÄNGA SPIRAL 40° HSS-E 6H Typ R40VAT-XY	371	18:268
48	65692	FINGÄNGA SPIRAL 40° HSS-E 6G Typ R40N	371	18:269
48	65693	FINGÄNGA SPIRAL 40° HSS-E 6G Typ R40N-VAP	371	18:269

SWEBOLT AB

TEL. 08-584 909 60 FAX. 08-583 581 82

BILD	ART.GR.	BENÄMNING	DIN	SIDA
48	65694	FINGÄNGA SPIRAL 40° HSS-E 6G Typ R40N-TiN	371	18:269
48	65695	FINGÄNGA SPIRAL 40° HSS-E 6G Typ R40N-TiCN	371	18:269
48	65696	FINGÄNGA SPIRAL 40° HSS-E 6HX Typ R40VA	371	18:270
48	65697	FINGÄNGA SPIRAL 40° HSS-E 6HX Typ R40VA-VAP	371	18:270
48	65698	FINGÄNGA SPIRAL 40° HSS-E 6HX Typ R40VA-TiCN	371	18:270
48	65699	FINGÄNGA SPIRAL 40° HSS-E 6HX Typ R40VA-XY	371	18:270
48	65700	FINGÄNGA SPIRAL 40° HSS-E 6HX Typ R40VAT	371	18:270
48	65701	FINGÄNGA SPIRAL 40° HSS-E 6HX Typ R40VAT-VAP	371	18:270
48	65702	FINGÄNGA SPIRAL 40° HSS-E 6HX Typ R40VAT-TiCN	371	18:270
48	65703	FINGÄNGA SPIRAL 40° HSS-E 6HX Typ R40VAT-XY	371	18:270
47	65704	FINGÄNGA SPIRAL 40° HSS-E 6H Typ R40N	374	18:271
47	65705	FINGÄNGA SPIRAL 40° HSS-E 6H Typ R40N-VAP	374	18:271
47	65706	FINGÄNGA SPIRAL 40° HSS-E 6H Typ R40N-TiN	374	18:271
47	65707	FINGÄNGA SPIRAL 40° HSS-E 6H Typ R40N-TiCN	374	18:271
47	65708	FINGÄNGA SPIRAL 40° HSS-E 6H Typ R40VA	374	18:271
47	65709	FINGÄNGA SPIRAL 40° HSS-E 6H Typ R40VA-VAP	374	18:271
47	65710	FINGÄNGA SPIRAL 40° HSS-E 6H Typ R40VA-TiCN	374	18:271
47	65711	FINGÄNGA SPIRAL 40° HSS-E 6H Typ R40VA-XY	374	18:271
47	65712	FINGÄNGA SPIRAL 40° HSS-E 6H Typ R40NT	374	18:272
47	65713	FINGÄNGA SPIRAL 40° HSS-E 6H Typ R40NT-VAP	374	18:272
47	65714	FINGÄNGA SPIRAL 40° HSS-E 6H Typ R40NT-TiN	374	18:272
47	65715	FINGÄNGA SPIRAL 40° HSS-E 6H Typ R40NT-TiCN	374	18:272
47	65716	FINGÄNGA SPIRAL 40° HSS-E 6H Typ R40VAT	374	18:272
47	65717	FINGÄNGA SPIRAL 40° HSS-E 6H Typ R40VAT-VAP	374	18:272
47	65718	FINGÄNGA SPIRAL 40° HSS-E 6H Typ R40VAT-TiCN	374	18:272
47	65719	FINGÄNGA SPIRAL 40° HSS-E 6H Typ R40VAT-XY	374	18:272
47	65720	FINGÄNGA SPIRAL 40° HSS-E 6G Typ R40N	374	18:272
47	65721	FINGÄNGA SPIRAL 40° HSS-E 6G Typ R40N-VAP	374	18:272
47	65722	FINGÄNGA SPIRAL 40° HSS-E 6G Typ R40N-TiN	374	18:272
47	65723	FINGÄNGA SPIRAL 40° HSS-E 6G Typ R40N-TiCN	374	18:272
47	65724	FINGÄNGA SPIRAL 40° HSS-E 6HX Typ R40VA	374	18:273
47	65725	FINGÄNGA SPIRAL 40° HSS-E 6HX Typ R40VA-VAP	374	18:273
47	65726	FINGÄNGA SPIRAL 40° HSS-E 6HX Typ R40VA-TiCN	374	18:273
47	65727	FINGÄNGA SPIRAL 40° HSS-E 6HX Typ R40VA-XY	374	18:273
47	65728	FINGÄNGA SPIRAL 40° HSS-E 6HX Typ R40VAT	374	18:273
47	65729	FINGÄNGA SPIRAL 40° HSS-E 6HX Typ R40VAT-VAP	374	18:273
47	65730	FINGÄNGA SPIRAL 40° HSS-E 6HX Typ R40VAT-TiCN	374	18:273
47	65731	FINGÄNGA SPIRAL 40° HSS-E 6HX Typ R40VAT-XY	374	18:273
47	65732	FINGÄNGA SPIRAL 40° HSS-E 6HX Typ R40GIK-TiCN	374	18:273
47	65733	FINGÄNGA SPIRAL 40° HSS-E 6HX Typ R40GIK-XY	374	18:273
47	65734	FINGÄNGA SPIRAL 45° HSS-E 6H Typ R45AI	374	18:274
47	65735	FINGÄNGA SPIRAL 45° HSS-E 6H Typ R45AI-NIT	374	18:274
47	65736	FINGÄNGA SPIRAL 45° HSS-E 6H Typ R45AI-TiCN	374	18:274
47	65740	FINGÄNGA SPIRAL 15° HSS-E 6H Typ R15H	374	18:275
47	65741	FINGÄNGA SPIRAL 15° HSS-E 6H Typ R15H-TiCN	374	18:275
47	65742	FINGÄNGA SPIRAL 15° HSS-E 6G Typ R15H	374	18:276
47	65743	FINGÄNGA SPIRAL 15° HSS-E 6G Typ R15H-TiCN	374	18:276
47	65744	FINGÄNGA SPIRAL 15° HSS-E 6HX Typ R15GG	374	18:277
47	65745	FINGÄNGA SPIRAL 15° HSS-E 6HX Typ R15GG-NIT	374	18:277

SWEBOLT AB

TEL. 08-584 909 60 FAX. 08-583 581 82

<u>BILD</u>	<u>ART.GR.</u>	<u>BENÄMNING</u>	<u>DIN</u>	<u>SIDA</u>
47	65746	FINGÄNGA SPIRAL 15° HSS-E 6HX Typ R15GG-TiN	374	18:277
47	65747	FINGÄNGA SPIRAL 15° HSS-E VÄNSTER 6H Typ L15N	374	18:278
47	65748	FINGÄNGA SPIRAL 15° HSS-E VÄNSTER 6H Typ L15N-VAP	374	18:278
SPÅNDRIVANDE FINGÄNGA MASKINGÄNGTAPP				
47	65749	FINGÄNGA SPÅNDRIVANDE HSS-E 6H Typ BH	374	18:279
47	65750	FINGÄNGA SPÅNDRIVANDE HSS-E 6H Typ BH-TICN	374	18:279
47	65751	FINGÄNGA SPÅNDRIVANDE HSS-E 6H Typ BN	374	18:279
47	65752	FINGÄNGA SPÅNDRIVANDE HSS-E 6H Typ BN-VAP	374	18:279
47	65753	FINGÄNGA SPÅNDRIVANDE HSS-E 6H Typ BN-TiN	374	18:279
47	65754	FINGÄNGA SPÅNDRIVANDE HSS-E 6H Typ BVA	374	18:280
47	65755	FINGÄNGA SPÅNDRIVANDE HSS-E 6H Typ BVA-VAP	374	18:280
47	65756	FINGÄNGA SPÅNDRIVANDE HSS-E 6H Typ BVA-TiN	374	18:280
47	65757	FINGÄNGA SPÅNDRIVANDE HSS-E 6H Typ BAI	374	18:280
47	65758	FINGÄNGA SPÅNDRIVANDE HSS-E 6H Typ BAI-TiN	374	18:280
47	65759	FINGÄNGA SPÅNDRIVANDE HSS-E 6H Typ BAI-TICN	374	18:280
SPÅNDRIVANDE FINGÄNGA RULLGÄNGTAPP				
47	65760	FINGÄNGA SPÅNDRIVANDE RULLGÄNGTAPP HSS-E 6H Typ BLN	374	18:280
47	65761	FINGÄNGA SPÅNDRIVANDE RULLGÄNGTAPP HSS-E 6H Typ BLN-TiN	374	18:280
47	65762	FINGÄNGA SPÅNDRIVANDE RULLGÄNGTAPP HSS-E 6H Typ BLNS	374	18:280
47	65763	FINGÄNGA SPÅNDRIVANDE RULLGÄNGTAPP HSS-E 6G Typ BLNS-TIN	374	18:280
SPÅNDRIVANDE FINGÄNGA MASKINGÄNGTAPP				
47	65764	FINGÄNGA SPÅNDRIVANDE HSS-E 6G Typ BN	374	18:281
47	65765	FINGÄNGA SPÅNDRIVANDE HSS-E 6G Typ BN-VAP	374	18:281
47	65766	FINGÄNGA SPÅNDRIVANDE HSS-E 6G Typ BN-TiN	374	18:281
47	65767	FINGÄNGA SPÅNDRIVANDE HSS-E 6G Typ BH	374	18:281
47	65768	FINGÄNGA SPÅNDRIVANDE HSS-E 6G Typ BH-TICN	374	18:281
47	65769	FINGÄNGA SPÅNDRIVANDE HSS-E 6HX Typ BVA	374	18:282
47	65770	FINGÄNGA SPÅNDRIVANDE HSS-E 6HX Typ BVA-VAP	374	18:282
47	65771	FINGÄNGA SPÅNDRIVANDE HSS-E 6HX Typ BVA-TiN	374	18:282
47	65772	FINGÄNGA SPÅNDRIVANDE HSS-E 6HX Typ BCNIK	374	18:282
47	65773	FINGÄNGA SPÅNDRIVANDE HSS-E 6HX Typ BCNIK-TICN	374	18:282
INTERRUPT SPÅNDRIVANDE FINGÄNGA MASKINGÄNGTAPP				
45	65774	FING. INTERRUPT spåndrivande HSS-E 6H Typ BVAAZ	374	18:283
49	65775	FING. INTERRUPT spåndrivande HSS-E 6H Typ BVAAZ-VAP	374	18:283
49	65776	FING. INTERRUPT spåndrivande HSS-E 6H Typ BVAAZ-TiN	374	18:283
49	65777	FING. INTERRUPT spåndrivande HSS-E 6HX Typ BVAAZ	374	8:284
49	65778	FING. INTERRUPT spåndrivande HSS-E 6HX Typ BVAAZ-VAP	374	18:284
49	65779	FING. INTERRUPT spåndrivande HSS-E 6HX Typ BVAAZ-TiN	374	18:284
43	65780	FINGÄNGA RAK HSS-E 6H Typ CAI	374	18:285
43	65781	FINGÄNGA RAK HSS-E 6H Typ CAI-TiN	374	18:285
43	65782	FINGÄNGA RAK HSS-E 6H Typ CN	374	18:285
43	65783	FINGÄNGA RAK HSS-E 6H Typ CN-TiN	374	18:285
43	65784	FINGÄNGA RAK HSS-E 6G Typ CN	374	18:286

SWEBOLT AB

TEL. 08-584 909 60 FAX. 08-583 581 82

<u>BILD</u>	<u>ART.GR.</u>	<u>BENÄMNING</u>	<u>DIN</u>	<u>SIDA</u>
43	65785	FINGÄNGA RAK HSS-E 6G Typ CN-TiN	374	18:286
43	65786	FINGÄNGA RAK HSS-E 6HX Typ EMS	374	18:287
43	65787	FINGÄNGA RAK HSS-E 6HX Typ CGG	374	18:287
43	65788	FINGÄNGA RAK HSS-E 6HX Typ CGG-NIT	374	18:287
43	65789	FINGÄNGA RAK HSS-E 6HX Typ CGG-TiN	374	18:287

**UNC – UNF – RÖRGÄNGOR – TRAPETSGÄNGOR FINNS STORT URVAL
PRIS VID FÖRFRÅGAN**

SWEBOLT AB

TEL. 08-584 909 60 FAX. 08-583 581 82

ARTIKELLISTA

2013-2014

BITSLÄNGD = 25mm

Bits för GIPSSKIVESKRUV. Phillips Nr 2

Skaft 1/4" längd 25mm

C:A PRIS /100 ST X

BESTÄLLNINGSEXEMPEL: 680002025 - BITS PH Nr 2x25mm

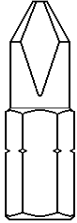

BITS 1/4" SKAFT LÄNGD 25mm

PHILLIPS

PRIS / 100 ST	
PHILLIPS	100 ST
PH 0	
PH 1	X
PH 2	X
PH 3	X

BESTÄLLNINGSEXEMPEL:
680003025 - BITS PH Nr 3x25mm

POZI

PRIS / 100 ST	
POZI	100 ST
PZ 1	X
PZ 2	X
PZ 3	X

BESTÄLLNINGSEXEMPEL:
680022025 - BITS POZI Nr 2x25mm



STAR

C:A PRIS/100ST			
DIM mm	PRIS	DIM mm	PRIS
T-6		T-20	X
T-7		T-25	X
T-8		T-27	
T-9	X	T-30	X
T-10	X	T-40	X
T-15	X		

BESTÄLLNINGSEXEMPEL:
6801015251 - BITS STAR T-15x25mm

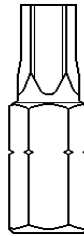

STAR KONISK 3°

C:A PRIS/100ST			
DIM mm	PRIS	DIM mm	PRIS
T-6		T-20	X
T-7		T-25	X
T-8		T-27	
T-9	X	T-30	X
T-10	X	T-40	X
T-15	X		

BESTÄLLNINGSEXEMPEL:
680101525 - BITS STAR T-15x25mm

6-KANT

C:A PRIS/100ST			
DIM mm	PRIS	DIM mm	PRIS
1,5	X	5	X
2	X	6	X
2,5	X	7	X
3	X	8	X
4	X	10	X

BESTÄLLNINGSEXEMPEL:
680305025 - BITS 6-KANT 5x25mm

C:A PRIS/100ST	
6-KANT	PRIS
1/16	
5/64	F
3/32	Ö
7/64	R
1/8	F
9/64	R
5/32	Å
3/16	G
7/32	A
1/4	N
5/16	

VI HAR ÄVEN LÅNGA (50mm/70mm/90mm/100mm/150mm) MASKINBITS !

SWEBOLT AB

TEL 08 - 555 975 00 FAX 08 - 583 581 82

ARTIKELLISTA

2013-2014

MUTTERHYLSA 1/4" SKAFT

MAGNETISK

PRIS / 100ST		
6-KANT	LÄNGD	PRIS
6	42	X
7	42	X
8	42	X
10	42	X
11	42	X
12	42	X
13	42	X
14	42	X
7	65	X
8	65	X
10	65	X
11	65	X
12	65	X
13	65	X
14	65	

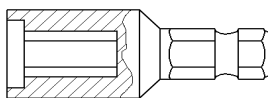

OMAGNETISK

PRIS / 100ST		
6-KANT	LÄNGD	PRIS
6	65	X
7	65	X
8	65	X
10	65	X
11	65	X
12	65	X
13	65	X
14	65	X
7	100	X
8	100	X
10	100	X
11	100	X
12	100	X
13	100	X
14	100	

BESTÄLLNINGSEXEMPEL: 6825013 - MUTTERHYLSA 13mmX42 MAGNETISK

BESTÄLLNINGSEXEMPEL: 6826013 - MUTTERHYLSA 13mmX65 MAGNETISK

MAGNETISK BITSHÅLLARE

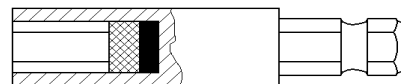

C:A PRIS / ST					
C-RING	YTTERD.	TOT.LÄNGD		HÅLLARE	PRIS
UTAN	10	60	2 DELAD	ROSTFRI	X
UTAN	10	125	2 DELAD	ROSTFRI	X
UTAN	10	60	2 DELAD	STÅL	X
MED	11	60	1 DEL	ROSTFRI	X
MED	11	75	2 DELAD	ROSTFRI	X
MED	11	75	1 DEL	ROSTFRI	X
MED	11	75	1 DEL	ROSTFRI	X

MAGNETISK BITSHÅLLARE MED SNABBCHUCK

1/4" SKAFT. 2 DELAD MED ROSTFRI KROPP

LÄNGD	PRIS / ST
51	X
60	X
75	X

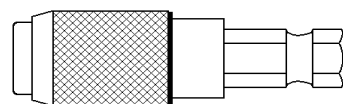

BESTÄLLNINGSEXEMPEL: 6828001 - BITSHÅLLARE 51mm SNABBCHUCK

SWEBOLT AB

TEL 08 - 555 975 00 FAX 08 - 583 581 82

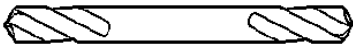

ARTIKELLISTA

2013-2014

KORT BORR - POPNITSBORR DUBBEL

L = TOTALLÄNGD L1 = SPIRALLÄNGD, LÄNGDER GÄLLER FÖR KORT BORR

C:A PRIS/ST							
Ø	L/L1	ENKEL	DUBBEL	Ø	L/L1	ENKEL	DUBBEL
2,00	38/7,5		X	4,70	58/16	X	
2,10	38/7,5			4,80	62/17	X	
2,20	40/8,5			4,90	62/17	X	X
2,30	40/8,5			5,00	62/17	X	X
2,40	43/9,5			5,10	62/17	X	X
2,45	43/9,5			5,20	62/17	X	X
2,50	43/9,5		X	5,30	62/17	X	
2,60	43/9,5			5,40	66/19	X	
2,70	46/11			5,50	66/19	X	X
2,75	46/11			5,60	66/19	X	
2,80	46/11			5,70	66/19	X	
2,90	46/11			5,80	66/19	X	
3,00	46/11	X	X	6,00	66/19	X	X
3,10	49/11	X	X	6,10	70/21	X	
3,20	49/11	X	X	6,20	70/21	X	X
3,25	49/11	X	X	6,30	70/21	X	
3,30	49/11	X	X	6,40	70/21	X	
3,40	52/12	X		6,50	70/21	X	X
3,50	52/12	X	X	6,80	74/24	X	X
3,60	52/12	X		7,00	74/24	X	X
3,65	52/12			7,10	74/24	X	
3,70	52/12	X		7,50	74/24	X	
3,80	55/14	X		8,00	79/25	X	X
4,00	55/14	X	X	8,50	79/25	X	
4,10	55/14	X	X	8,60	84/25	X	
4,20	55/14	X	X	9,00	84/25	X	X
4,30	58/16	X		9,50	84/25	X	
4,40	58/16	X		10,00	89/25	X	X
4,50	58/16	X	X				
4,60	58/16	X					

BESTÄLLNINGSEXEMPEL: 601250250 - POPNITSBORR 2,50 SLIPAD

BORRAR-GÄNGTAPPAR-FRÄSAR FINNS I VÅRA VERKTYGSPRISLISTOR OCH HEMSIDA

SWEBOLT AB

TEL 08 - 555 975 00 FAX 08 - 583 581 82

ARTIKELLISTA

2013-2014



BORR NR 100

DIN 338N HSS SLIPAD

L = TOTALLÄNGD L1 = SPIRALLÄNGD

C:A PRIS / STYCK											
DIAM	L / L1	PRIS	DIAM	L / L1	PRIS	DIAM	L / L1	PRIS	DIAM	L / L1	PRIS
0,20	18/3		2,65	57/30	X	5,70	93/57	X	10,75	133/87	X
0,30	19/3	X	2,70	61/33	X	5,75	93/57	X	10,80	133/87	X
0,32	19/4	X	2,75	61/33	X	5,80	93/57	X	10,90	133/87	X
0,35	19/4	X	2,80	61/33	X	5,90	93/57	X	11,00	142/94	X
0,38	19/4		2,85	61/33	X	6,00	93/57	X	11,10	142/94	X
0,40	20/5	X	2,90	61/33	X	6,10	101/63	X	11,20	142/94	X
0,42	20/5		2,95	61/33	X	6,20	101/63	X	11,25	142/94	X
0,45	20/5	X	3,00	61/33	X	6,25	101/63	X	11,30	142/94	X
0,48	20/5	X	3,05	65/36	X	6,30	101/63	X	11,40	142/94	X
0,50	22/6	X	3,10	65/36	X	6,40	101/63	X	11,50	142/94	X
0,52	22/6		3,15	65/36	X	6,50	101/63	X	11,60	142/94	X
0,55	24/7	X	3,20	65/36	X	6,60	101/63	X	11,70	142/94	X
0,58	24/7		3,25	65/36	X	6,70	101/63	X	11,75	142/94	X
0,60	24/7	X	3,30	65/36	X	6,75	109/69	X	11,80	142/94	X
0,62	26/8		3,35	65/36	X	6,80	109/69	X	11,90	142/94	X
0,65	26/8	X	3,40	70/39	X	6,90	109/69	X	12,00	151/101	X
0,68	28/9		3,45	70/39	X	7,00	109/69	X	12,10	151/101	X
0,70	28/9	X	3,50	70/39	X	7,10	109/69	X	12,20	151/101	X
0,72	28/9	X	3,55	70/39	X	7,20	109/69	X	12,25	151/101	X
0,75	28/9	X	3,60	70/39	X	7,25	109/69	X	12,30	151/101	X
0,78	30/10		3,65	70/39	X	7,30	109/69	X	12,40	151/101	X
0,80	30/10	X	3,70	70/39	X	7,40	109/69	X	12,50	151/101	X
0,82	30/10		3,75	70/39	X	7,50	109/69	X	12,60	151/101	X
0,85	30/10	X	3,80	75/43	X	7,60	117/75	X	12,70	151/101	X
0,88	32/11		3,85	75/43	X	7,70	117/75	X	12,75	151/101	X
0,90	32/11	X	3,90	75/43	X	7,75	117/75	X	12,80	151/101	X
0,92	32/11		3,95	75/43	X	7,80	117/75	X	12,90	151/101	X
0,95	32/11	X	4,00	75/43	X	7,90	117/75	X	13,00	151/101	X
0,98	34/12		4,05	75/43	X	8,00	117/75	X	13,10	151/101	X
1,00	34/12	X	4,10	75/43	X	8,10	117/75	X	13,20	151/101	X
1,05	34/12	X	4,15	75/43	X	8,20	117/75	X	13,25	151/101	X
1,10	36/14	X	4,20	75/43	X	8,25	117/75	X	13,30	160/108	X
1,15	36/14	X	4,25	75/43	X	8,30	117/75	X	13,40	160/108	X
1,20	38/16	X	4,30	80/47	X	8,40	117/75	X	13,50	160/108	X
1,25	38/16	X	4,35	80/47	X	8,50	117/75	X	13,60	160/108	X
1,30	38/16	X	4,40	80/47	X	8,60	125/81	X	13,70	160/108	X
1,35	40/18	X	4,45	80/47	X	8,70	125/81	X	13,75	160/108	X
1,40	40/18	X	4,50	80/47	X	8,75	125/81	X	13,80	160/108	X
1,45	40/18	X	4,55	80/47	X	8,80	125/81	X	13,90	160/108	X
1,50	40/18	X	4,60	80/47	X	8,90	125/81	X	14,00	160/108	X
1,55	43/20	X	4,65	80/47	X	9,00	125/81	X	14,25	160/108	X
1,60	43/20	X	4,70	80/47	X	9,10	125/81	X	14,50	169/114	X
1,65	43/20	X	4,75	80/47	X	9,20	125/81	X	14,75	169/114	X
1,70	43/20	X	4,80	86/52	X	9,25	125/81	X	15,00	169/114	X
1,75	46/22	X	4,85	86/52	X	9,30	125/81	X	15,25	169/114	X
1,80	46/22	X	4,90	86/52	X	9,40	125/81	X	15,50	178/120	X
1,85	46/22	X	4,95	86/52	X	9,50	125/81	X	15,75	178/120	X
1,90	46/22	X	5,00	86/52	X	9,60	133/87	X	16,00	178/120	X
2,00	49/24	X	5,05	86/52	X	9,70	133/87	X	16,50	184/125	X
2,05	49/24	X	5,10	86/52	X	9,75	133/87	X	17,00	191/130	X
2,10	49/24	X	5,15	86/52	X	9,80	133/87	X	17,50	191/130	X
2,15	53/27	X	5,20	86/52	X	9,90	133/87	X	18,00	191/130	X
2,20	53/27	X	5,25	86/52	X	10,00	133/87	X	18,50	198/135	X
2,25	53/27	X	5,30	86/52	X	10,10	133/87	X	19,00	198/135	X
2,30	53/27	X	5,35	86/52	X	10,20	133/87	X	19,50	205/140	X
2,35	53/27	X	5,40	93/57	X	10,25	133/87	X	20,00	205/140	X
2,40	57/30	X	5,45	93/57	X	10,30	133/87	X	21,00	213/145	
2,45	57/30	X	5,50	93/57	X	10,40	133/87	X	22,00	221/150	
2,50	57/30	X	5,55	93/57	X	10,50	133/87	X	23,00	229/155	
2,55	57/30	X	5,60	93/57	X	10,60	133/87	X	24,00	236/160	
2,60	57/30	X	5,65	93/57	X	10,70	133/87	X	25,00	236/160	

BESTÄLLNINGSEXEMPEL: 601000250 - BORR 2,50mm Nr 100 SLIPAD

SWEBOLT AB

TEL 08 - 555 975 00 FAX 08 - 583 581 82

ARTIKELLISTA

2013-2014

BORR NR 100

DIN 338 HSS *PRECISE*



L = TOTALLÄNGD L1 = SPIRALLÄNGD

C:A PRIS / STYCK

DIM	L / L1	PRIS	DIM	L / L1	PRIS	DIM	L / L1	PRIS	DIM	L / L1	PRIS
0,20	18/3		2,65	57/30	X	5,70	93/57	X	10,75	133/87	X
0,30	19/3		2,70	61/33	X	5,75	93/57	X	10,80	133/87	X
0,32	19/4		2,75	61/33	X	5,80	93/57	X	10,90	133/87	X
0,35	19/4		2,80	61/33	X	5,90	93/57	X	11,00	142/94	X
0,38	19/4		2,85	61/33	X	6,00	93/57	X	11,10	142/94	X
0,40	20/5		2,90	61/33	X	6,10	101/63	X	11,20	142/94	X
0,42	20/5		2,95	61/33	X	6,20	101/63	X	11,25	142/94	X
0,45	20/5		3,00	61/33	X	6,25	101/63	X	11,30	142/94	X
0,48	20/5		3,05	65/36		6,30	101/63	X	11,40	142/94	X
0,50	22/6		3,10	65/36	X	6,40	101/63	X	11,50	142/94	X
0,52	22/6		3,15	65/36		6,50	101/63	X	11,60	142/94	X
0,55	24/7		3,20	65/36	X	6,60	101/63	X	11,70	142/94	X
0,58	24/7		3,25	65/36		6,70	101/63	X	11,75	142/94	X
0,60	24/7		3,30	65/36	X	6,75	109/69	X	11,80	142/94	X
0,62	26/8		3,35	65/36		6,80	109/69	X	11,90	142/94	X
0,65	26/8		3,40	70/39	X	6,90	109/69	X	12,00	151/101	X
0,68	28/9		3,45	70/39		7,00	109/69	X	12,10	151/101	X
0,70	28/9		3,50	70/39	X	7,10	109/69	X	12,20	151/101	X
0,72	28/9		3,55	70/39		7,20	109/69	X	12,25	151/101	X
0,75	28/9		3,60	70/39	X	7,25	109/69	X	12,30	151/101	
0,78	30/10		3,65	70/39		7,30	109/69	X	12,40	151/101	X
0,80	30/10		3,70	70/39	X	7,40	109/69	X	12,50	151/101	X
0,82	30/10		3,75	70/39	X	7,50	109/69	X	12,60	151/101	X
0,85	30/10		3,80	75/43	X	7,60	117/75	X	12,70	151/101	X
0,88	32/11		3,85	75/43		7,70	117/75	X	12,75	151/101	
0,90	32/11		3,90	75/43	X	7,75	117/75	X	12,80	151/101	X
0,92	32/11		3,95	75/43		7,80	117/75	X	12,90	151/101	X
0,95	32/11		4,00	75/43	X	7,90	117/75	X	13,00	151/101	X
0,98	34/12		4,05	75/43		8,00	117/75	X	13,10	151/101	
1,00	34/12	X	4,10	75/43	X	8,10	117/75	X	13,20	151/101	X
1,05	34/12		4,15	75/43		8,20	117/75	X	13,25	151/101	X
1,10	36/14	X	4,20	75/43	X	8,25	117/75	X	13,30	160/108	X
1,15	36/14		4,25	75/43	X	8,30	117/75	X	13,40	160/108	X
1,20	38/16	X	4,30	80/47	X	8,40	117/75	X	13,50	160/108	X
1,25	38/16		4,35	80/47		8,50	117/75	X	13,60	160/108	X
1,30	38/16	X	4,40	80/47	X	8,60	125/81	X	13,70	160/108	X
1,35	40/18		4,45	80/47		8,70	125/81	X	13,75	160/108	X
1,40	40/18	X	4,50	80/47	X	8,75	125/81	X	13,80	160/108	X
1,45	40/18		4,55	80/47		8,80	125/81	X	13,90	160/108	X
1,50	40/18	X	4,60	80/47	X	8,90	125/81	X	14,00	160/108	X
1,55	43/20		4,65	80/47		9,00	125/81	X	14,25	160/108	X
1,60	43/20	X	4,70	80/47	X	9,10	125/81	X	14,50	169/114	X
1,65	43/20		4,75	80/47	X	9,20	125/81	X	14,75	169/114	X
1,70	43/20	X	4,80	86/52	X	9,25	125/81	X	15,00	169/114	X
1,75	46/22		4,85	86/52		9,30	125/81	X	15,25	169/114	X
1,80	46/22	X	4,90	86/52	X	9,40	125/81	X	15,50	178/120	X
1,85	46/22		4,95	86/52		9,50	125/81	X	15,75	178/120	X
1,90	46/22	X	5,00	86/52	X	9,60	133/87	X	16,00	178/120	X
2,00	49/24	X	5,05	86/52		9,70	133/87	X	16,50	184/125	X
2,05	49/24	X	5,10	86/52	X	9,75	133/87	X	17,00	191/130	X
2,10	49/24	X	5,15	86/52		9,80	133/87	X	17,50	191/130	X
2,15	53/27	X	5,20	86/52	X	9,90	133/87	X	18,00	191/130	X
2,20	53/27	X	5,25	86/52	X	10,00	133/87	X	18,50	198/135	X
2,25	53/27	X	5,30	86/52	X	10,10	133/87	X	19,00	198/135	X
2,30	53/27	X	5,35	86/52		10,20	133/87	X	19,50	205/140	X
2,35	53/27	X	5,40	93/57	X	10,25	133/87	X	20,00	205/140	X
2,40	57/30	X	5,45	93/57		10,30	133/87	X	21,00	213/145	
2,45	57/30	X	5,50	93/57	X	10,40	133/87	X	22,00	221/150	
2,50	57/30	X	5,55	93/57		10,50	133/87	X	23,00	229/155	
2,55	57/30	X	5,60	93/57	X	10,60	133/87	X	24,00	236/160	
2,60	57/30	X	5,65	93/57		10,70	133/87	X	25,00	236/160	

BESTÄLLNINGSEXEMPEL: 600990550 - BORR 5,50mm PRECISE

SWEBOLT AB

TEL 08 - 555 975 00 FAX 08 - 583 581 82

18:19

ARTIKELLISTA

2013-2014

BORR NR 130 DIN 345 VALSAD



L = TOTALLÄNGD L1 = SPIRALLÄNGD

C:A PRIS/STYCK

DIM	L/L1	MK	PRIS	DIM	L/L1	MK	PRIS	DIM	L/L1	MK	PRIS	DIM	L/L1	MK	PRIS
6,00	138/57	1	X	13,40	189/108	1		22,50	253/155	2	X	39,00	349/200	4	X
6,20	144/63	1	X	13,50	189/108	1	X	22,75	253/155	2	X	39,50	349/200	4	X
6,25	144/63	1	X	13,75	189/108	1	X	22,80	253/155	2		40,00	349/200	4	X
6,40	144/63	1		13,80	189/108	1	X	23,00	253/155	2	X	40,50	354/205	4	X
6,50	144/63	1	X	13,90	189/108	1		23,25	253/155	3	X	41,00	354/205	4	X
6,80	150/69	1	X	14,00	189/108	1	X	23,50	253/155	3	X	41,50	354/205	4	X
7,00	150/69	1	X	14,20	212/114	2		23,75	281/160	3	X	42,00	354/205	4	X
7,20	150/69	1	X	14,25	212/114	2	X	24,00	281/160	3	X	42,50	354/205	4	X
7,25	150/69	1	X	14,30	212/114	2		24,25	281/160	3	X	43,00	359/210	4	X
7,50	150/69	1	X	14,50	212/114	2	X	24,50	281/160	3	X	43,50	359/210	4	X
7,75	156/75	1	X	14,70	212/114	2		24,75	281/160	3	X	44,00	359/210	4	X
7,80	156/75	1	X	14,75	212/114	2	X	25,00	281/160	3	X	44,50	359/210	4	X
7,90	156/75	1		14,80	212/114	2		25,25	286/165	3	X	45,00	359/210	4	X
8,00	156/75	1	X	15,00	212/114	2	X	25,50	286/165	3	X	45,50	364/215	4	X
8,20	156/75	1	X	15,10	218/120	2		25,75	286/165	3	X	46,00	364/215	4	X
8,25	156/75	1	X	15,20	218/120	2		26,00	286/165	3	X	46,50	364/215	4	X
8,30	156/75	1		15,25	218/120	2	X	26,25	286/165	3	X	47,00	364/215	4	X
8,50	156/75	1	X	15,50	218/120	2	X	26,50	286/165	3	X	47,50	364/215	4	X
8,75	162/81	1	X	15,75	218/120	2	X	26,75	291/170	3	X	48,00	369/220	4	X
8,80	162/81	1	X	15,80	218/120	2		27,00	291/170	3	X	48,50	369/220	4	X
9,00	162/81	1	X	15,90	223/125	2		27,25	291/170	3	X	49,00	369/220	4	X
9,10	162/81	1		16,00	218/120	2	X	27,50	291/170	3	X	49,50	369/220	4	X
9,20	162/81	1	X	16,20	223/125	2		27,75	291/170	3	X	50,00	369/220	4	X
9,25	162/81	1	X	16,25	223/125	2	X	28,00	291/170	3	X	50,50	374/225	4	
9,50	162/81	1	X	16,50	223/125	2	X	28,25	296/175	3	X	51,00	412/225	5	X
9,75	168/87	1	X	16,70	223/125	2		28,50	296/175	3	X	52,00	412/225	5	X
9,80	168/87	1	X	16,75	223/125	2	X	28,75	296/175	3	X	53,00	412/226	5	X
9,90	168/87	1		16,80	223/125	2		29,00	296/175	3	X	54,00	417/230	5	X
10,00	168/87	1	X	17,00	223/125	2	X	29,25	296/175	3	X	55,00	417/231	5	X
10,10	168/87	1	X	17,20	228/130	2		29,50	296/175	3	X	56,00	417/232	5	X
10,20	168/87	1	X	17,25	228/130	2	X	29,75	296/175	3	X	57,00	422/235	5	X
10,25	168/87	1	X	17,50	228/130	2	X	30,00	296/175	3	X	58,00	422/236	5	X
10,30	168/87	1	X	17,75	228/130	2	X	30,25	301/180	3	X	60,00	422/237	5	X
10,40	168/87	1		17,80	228/130	2		30,50	301/180	3	X	61,00	427/240	5	
10,50	168/87	1	X	17,90	228/130	2		30,75	301/180	3	X	62,00	427/240	5	
10,70	175/94	1		18,00	228/130	2	X	31,00	301/180	3	X	63,00	427/240	5	
10,75	175/94	1	X	18,20	233/135	2		31,25	301/180	3	X	64,00	432/245	5	
10,80	175/94	1	X	18,25	233/135	2	X	31,50	301/180	3	X	65,00	432/245	5	
10,90	175/94	1		18,50	233/135	2	X	31,75	301/180	3	X	66,00	432/245	5	
11,00	175/94	1	X	18,70	233/135	2		32,00	334/185	4	X	67,00	432/245	5	
11,10	175/94	1		18,75	233/135	2	X	32,25	334/185	4		68,00	437/250	5	
11,20	175/94	1	X	18,80	233/135	2		32,50	334/185	4	X	69,00	437/250	5	
11,25	175/94	1	X	19,00	233/135	2	X	32,75	334/185	4		70,00	437/250	5	
11,50	175/94	1	X	19,25	238/140	2		33,00	334/185	4	X	71,00	437/250	5	
11,60	175/94	1		19,50	238/140	2	X	33,25	334/185	4		72,00	442/255	5	
11,75	175/94	1	X	19,75	238/140	2	X	33,50	334/185	4	X	73,00	442/255	5	
11,80	175/94	1	X	19,80	238/140	2		33,75	339/190	4		74,00	442/255	5	
11,90	182/101	1		20,00	238/140	2	X	34,00	339/190	4	X	75,00	442/255	5	
12,00	182/101	1	X	20,25	243/145	2	X	34,25	339/190	4		76,00	447/250	5	
12,20	182/101	1	X	20,50	243/145	2	X	34,50	339/190	4	X	77,00	514/260	6	
12,25	182/101	1	X	20,75	243/145	2	X	34,75	339/190	4		78,00	514/260	6	
12,40	182/101	1		20,80	243/145	2		35,00	339/190	4	X	79,00	514/260	6	
12,50	182/101	1	X	21,00	243/145	2	X	35,50	339/190	4	X	80,00	514/260	6	
12,60	182/101	1		21,25	248/150	2	X	35,75	344/195	4		82,00	519/265	6	
12,75	182/101	1	X	21,50	248/150	2	X	36,00	344/195	4	X	85,00	519/265	6	
12,80	182/101	1	X	21,75	248/150	2	X	36,50	344/195	4	X	88,00	524/270	6	
12,90	182/101	1		21,80	248/150	2		37,00	344/195	4	X	90,00	524/270	6	
13,00	182/101	1	X	22,00	248/150	2	X	37,50	344/195	4	X	95,00	529/275	6	
13,20	182/101	1	X	22,25	248/150	2	X	38,00	349/200	4	X	100,00	534/280	6	
13,25	189/108	1	X					38,50	349/200	4	X				

BESTÄLLNINGSEXEMPEL: 601292200 - BORR 22,00mm Nr 130 VALSAD

NERA BORRAR-GÄNGTAPPAR-FRÄSAR I VÅRA VERKTYGSPRISLISTER OCH HEMSIDA
SWEBOLT AB

TEL 08 - 555 975 00 FAX 08 - 583 581 82

18:60



ARTIKELLISTA

2013-2014

BORR NR 130 MORSEKONA DIN 345 SLIPAD

L = TOTALLÄNGD L1 = SPIRALLÄNGD

C:A PRIS/STYCK															
DIM	L/L1	MK	PRIS	DIM	L/L1	MK	PRIS	DIM	L/L1	MK	PRIS	DIM	L/L1	MK	PRIS
6,00	138/57	1	X	11,40	175/94	1	X	17,10	228/130	2	X	28,25	296/175	3	X
6,20	144/63	1	X	11,50	175/94	1	X	17,20	228/130	2	X	28,50	296/175	3	X
6,25	144/63	1	X	11,60	175/94	1	X	17,25	228/130	2	X	28,75	296/175	3	X
6,30	144/63	1	X	11,70	175/94	1	X	17,50	228/130	2	X	28,80	296/175	3	X
6,40	144/63	1	X	11,75	175/94	1	X	17,75	228/130	2	X	29,00	296/175	3	X
6,50	144/63	1	X	11,80	175/94	1	X	17,80	228/130	2	X	29,25	296/175	3	X
6,60	144/63	1	X	11,90	182/101	1	X	18,00	228/130	2	X	29,50	296/175	3	X
6,70	144/63	1	X	12,00	182/101	1	X	18,10	228/130	2	X	29,75	296/175	3	X
6,80	150/69	1	X	12,10	182/101	1	X	18,20	233/135	2	X	29,80	296/175	3	X
7,00	150/69	1	X	12,20	182/101	1	X	18,25	233/135	2	X	30,00	296/175	3	X
7,10	150/69	1	X	12,25	182/101	1	X	18,50	233/135	2	X	30,25	301/180	3	X
7,20	150/69	1	X	12,40	182/101	1	X	18,75	233/135	2	X	30,50	301/180	3	X
7,25	150/69	1	X	12,50	182/101	1	X	18,80	233/135	2	X	30,75	301/180	3	X
7,30	150/69	1	X	12,60	182/101	1	X	19,00	233/135	2	X	30,80	301/180	3	X
7,40	156/75	1	X	12,75	182/101	1	X	19,10	238/140	2	X	31,00	301/180	3	X
7,50	150/69	1	X	12,80	182/101	1	X	19,20	238/140	2	X	31,25	301/180	3	X
7,60	156/75	1	X	12,90	182/101	1	X	19,25	238/140	2	X	31,50	301/180	3	X
7,70	156/75	1	X	13,00	182/101	1	X	19,50	238/140	2	X	31,75	301/180	3	X
7,75	156/75	1	X	13,20	182/101	1	X	19,75	238/140	2	X	32,00	334/185	4	X
7,80	156/75	1	X	13,25	189/108	1	X	19,80	238/140	2	X	32,25	334/185	4	X
7,90	156/75	1	X	13,30	189/108	1	X	20,00	238/140	2	X	32,50	334/185	4	X
8,00	156/75	1	X	13,40	189/108	1	X	20,25	243/145	2	X	32,75	334/185	4	X
8,10	156/75	1	X	13,50	189/108	1	X	20,50	243/145	2	X	33,00	334/185	4	X
8,20	156/75	1	X	13,60	189/108	1	X	20,75	243/145	2	X	33,25	334/185	4	X
8,25	156/75	1	X	13,70	189/108	1	X	20,80	243/145	2	X	33,50	334/185	4	X
8,30	156/75	1	X	13,75	189/108	1	X	21,00	243/145	2	X	33,75	339/190	4	X
8,40	156/75	1	X	13,80	189/108	1	X	21,25	248/150	2	X	34,00	339/190	4	X
8,50	156/75	1	X	13,90	189/108	1	X	21,50	248/150	2	X	34,25	339/190	4	X
8,60	162/81	1	X	14,00	189/108	1	X	21,75	248/150	2	X	34,50	339/190	4	X
8,70	162/81	1	X	14,10	189/108	1	X	21,80	248/150	2	X	34,75	339/190	4	X
8,75	162/81	1	X	14,20	212/114	2	X	22,00	248/150	2	X	34,80	339/190	4	X
8,80	162/81	1	X	14,25	212/114	2	X	22,25	248/150	2	X	35,00	339/190	4	X
9,00	162/81	1	X	14,30	212/114	2	X	22,50	253/155	2	X	35,50	339/190	4	X
9,10	162/81	1	X	14,40	212/114	2	X	22,75	253/155	2	X	35,75	344/195	4	X
9,20	162/81	1	X	14,50	212/114	2	X	22,80	253/155	2	X	36,00	344/195	4	X
9,25	162/81	1	X	14,60	212/114	2	X	23,00	253/155	2	X	36,50	344/195	4	X
9,40	162/81	1	X	14,70	212/114	2	X	23,25	253/155	3	X	37,00	344/195	4	X
9,50	162/81	1	X	14,75	212/114	2	X	23,50	253/155	3	X	37,50	344/195	4	X
9,60	168/87	1	X	14,80	212/114	2	X	23,75	281/160	3	X	38,00	349/200	4	X
9,70	168/87	1	X	14,90	212/114	2	X	24,00	281/160	3	X	38,50	349/200	4	X
9,75	168/87	1	X	15,00	212/114	2	X	24,25	281/160	3	X	39,00	349/200	4	X
9,80	168/87	1	X	15,10	218/120	2	X	24,50	281/160	3	X	39,50	349/200	4	X
9,90	168/87	1	X	15,20	218/120	2	X	24,75	281/160	3	X	40,00	349/200	4	X
10,00	168/87	1	X	15,25	218/120	2	X	24,80	281/160	3	X				
10,10	168/87	1	X	15,30	218/120	2	X	25,00	281/160	3	X				
10,20	168/87	1	X	15,40	218/120	2	X	25,25	286/165	3	X				
10,25	168/87	1	X	15,50	218/120	2	X	25,50	286/165	3	X				
10,30	168/87	1	X	15,60	218/120	2	X	25,75	286/165	3	X				
10,40	168/87	1	X	15,70	218/120	2	X	25,80	286/165	3	X				
10,50	168/87	1	X	15,75	218/120	2	X	26,00	286/165	3	X				
10,60	168/87	1	X	15,80	218/120	2	X	26,25	286/165	3	X				
10,70	175/94	1	X	15,90	223/125	2	X	26,50	286/165	3	X				
10,75	175/94	1	X	16,00	218/120	2	X	26,75	291/170	3	X				
10,80	175/94	1	X	16,10	223/125	2	X	26,80	291/170	3	X				
10,90	175/94	1	X	16,20	223/125	2	X	27,00	291/170	3	X				
11,00	175/94	1	X	16,25	223/125	2	X	27,25	291/170	3	X				
11,10	175/94	1	X	16,50	223/125	2	X	27,50	291/170	3	X				
11,20	175/94	1	X	16,75	223/125	2	X	27,75	291/170	3	X				
11,25	175/94	1	X	16,80	223/125	2	X	27,80	291/170	3	X				
11,30	175/94	1	X	17,00	223/125	2	X	28,00	291/170	3	X				

BESTÄLLNINGSEXEMPEL: 601302100 - BORR 21,00mm Nr 130 SLIPAD

SWEBOLT AB

TEL 08 - 555 975 00 FAX 08 - 583 581 82

ARTIKELLISTA

2013-2014

MASKINGÄNGTAPP DIN 371 SPIRAL Form C/39°RSP HSS-E 6H

RINGMÄRKTA GÄNGTAPPAR FÖR OLIKA MATERIAL	
BLÅ RING	FÖR ALLMÄNNA MATERIAL
RÖD RING	FÖR HÖGHÅLLFASTA MATERIAL
SVART RING	FÖR GJUTJÄRN OCH SEGJÄRN
VIT RING	FÖR ROSTFRIA OCH SYRAFASTA MATERIAL

GÄNGA	LÄNGD	GL.	SKAFTD.	Ø(FÄSTE)	PRIS/STYCK			
					BLÅ RING	VIT RING	RÖD RING	SVART RING
M3x0,5	56	6	3.5	2.7	X	X		
M4x0,7	63	7	4.5	3.4	X	X		
M5x0,8	70	8	6	4.9	X	X		
M6x1	80	10	6	4.9	X	X		
M8x1,25	90	14	8	6.2	X	X		
M10x1,5	100	16	10	8	X	X		

MASKINGÄNGTAPP DIN 376 SPIRAL Form C/39°RSP HSS-E 6H

GÄNGA	LÄNGD	GL.	SKAFTD.	Ø(FÄSTE)	PRIS/STYCK			
					BLÅ RING	VIT RING	RÖD RING	SVART RING
M12x1,75	110	18	9	7	X	X		
M14x2	110	20	11	9	X	X		
M16x2	110	22	12	9	X	X		
M18x2,5	125	25	14	11	X	X		
M20x2,5	140	25	16	12	X	X		

SET M3-M12

X X

MASKINGÄNGTAPP DIN 371 SPÅNDRIVANDE Form B HSS-E 6H

GÄNGA	LÄNGD	GL.	SKAFTD.	Ø(FÄSTE)	PRIS/STYCK			
					BLÅ RING	VIT RING	RÖD RING	SVART RING
M3x0,5	56	11	3.5	2.7	X	X		X
M4x0,7	63	13	4.5	3.4	X	X	X	X
M5x0,8	70	16	6	4.9	X	X	X	X
M6x1	80	19	6	4.9	X	X	X	X
M8x1,25	90	22	8	6.2	X	X	X	X
M10x1,5	100	24	10	8	X	X	X	X

MASKINGÄNGTAPP DIN 376 SPÅNDRIVANDE Form B HSS-E 6H

GÄNGA	LÄNGD	GL.	SKAFTD.	Ø(FÄSTE)	PRIS/STYCK			
					BLÅ RING	VIT RING	RÖD RING	SVART RING
M12x1,75	110	29	9	7	X	X		X
M14x2	110	30	11	9	X	X		X
M16x2	110	32	12	9	X	X		X
M18x2,5	125	34	14	11	X	X		X
M20x2,5	140	34	16	12	X	X		X

SET M3-M12

X X

X

MER VERKTYG FINNS I VÅRA VERKTYGSPRISLISTOR OCH HEMSIDA

SWEBOLT AB

TEL 08 - 555 975 00 FAX 08 - 583 58182



TEKNISK DATA

V-COIL GÄNGINSATSER DIN 8140

M / MF GÄNGA STIGNING	B	C	A		d1		W	Q	S	T	R
	mm	mm	MIN mm	MAX mm	MIN mm	MAX mm					
M 2 x 0.4	2,52	2,10	2,09	2,18	2,60	2,80	4,90	3,00	4,80	4,40	2,60
M 2.5 x 0.45	3,08	2,60	2,60	2,70	3,20	3,70	5,90	3,75	5,77	5,32	3,30
M 3 x 0.5	3,65	3,20	3,11	3,22	3,80	4,35	6,30	4,50	6,75	6,25	4,00
M 3.5 x 0.6	4,28	3,70	3,63	3,76	4,55	4,75	6,30	5,25	7,95	7,35	4,65
M 4 x 0.7	4,91	4,20	4,15	4,29	5,05	5,60	6,10	6,00	9,15	8,45	5,30
M 5 x 0.8	6,04	5,20	5,17	5,33	6,25	6,80	6,90	7,50	11,10	10,30	6,70
M 6 x 1.0	7,30	6,30	6,22	6,41	7,40	7,95	6,90	9,00	13,50	12,50	8,00
M 7 x 1.0	8,30	7,30	7,22	7,41	8,65	9,20	8,20	10,50	15,00	14,00	9,50
M 8 x 1.25	9,62	8,30	8,27	8,48	9,80	10,35	7,40	12,00	17,62	16,37	10,75
M 8 x 1.0	9,30	8,30	8,22	8,41	9,70	10,25	9,50	12,00	16,50	15,50	11,00
M 9 x 1.25	10,62	9,30	9,27	9,48	10,85	11,10	8,60	13,50	19,12	17,87	12,25
M 10 x 1.5	11,95	10,40	10,32	10,56	11,95	12,50	8,10	15,00	21,75	20,25	13,50
M 10 x 1.25	11,62	10,30	10,27	10,48	12,10	12,65	9,70	15,00	20,62	19,37	13,75
M 10 x 1.0	11,30	10,30	10,22	10,41	12,10	12,50	12,10	15,00	19,50	18,50	14,00
M 11 x 1.5	12,95	11,40	11,33	11,56	13,10	13,50	9,00	16,50	23,25	21,75	15,00
M 12 x 1.75	14,27	12,40	12,38	12,64	14,30	15,00	8,40	18,00	25,87	24,12	16,25
M 12 x 1.5	14,10	12,50	12,32	12,56	14,25	14,95	9,80	18,00	24,75	23,25	16,50
M 12 x 1.25	13,62	12,30	12,27	12,48	14,30	15,00	11,60	18,00	23,62	22,37	16,75
M 12 x 1.0	13,30	12,30	12,22	12,41	14,40	14,80	14,50	18,00	22,50	21,50	17,00
M 14 x 2.0	16,60	14,50	14,43	14,73	16,65	17,35	8,80	21,00	30,00	28,00	19,00
M 14 x 1.5	15,95	14,40	14,35	14,56	16,55	17,25	11,60	21,00	27,75	26,25	19,50
M 14 x 1.25	15,62	14,40	14,27	14,48	17,20	17,70	12,40	21,00	26,62	25,37	19,75
M 14 x 1.0	15,30	14,30	14,22	14,41	16,80	17,20	17,20	21,00	25,50	24,50	20,00
M 16 x 2.0	18,60	16,50	16,43	16,73	18,90	19,60	10,10	24,00	33,00	31,00	22,00
M 16 x 1.5	17,95	16,40	16,32	16,56	18,90	19,60	13,40	24,00	30,75	29,25	22,50
M 18 x 2.5	21,25	18,60	18,54	18,90	21,30	22,00	9,00	27,00	38,25	35,75	24,50
M 18 x 2.0	20,60	18,50	18,43	18,73	21,15	21,85	11,20	27,00	36,00	34,00	25,00
M 18 x 1.5	19,95	18,40	18,32	18,56	21,05	21,75	14,90	27,00	33,75	32,25	25,50
M 20 x 2.5	23,25	20,60	20,54	20,90	23,55	24,40	10,00	30,00	41,25	38,75	27,50
M 20 x 2.0	22,60	20,50	20,43	20,73	23,20	24,05	12,50	30,00	39,00	37,00	28,00
M 20 x 1.5	21,95	20,50	20,32	20,56	23,15	24,00	16,70	30,00	36,75	35,25	28,50
M 22 x 2.5	25,25	22,60	22,54	22,90	25,90	26,90	10,90	33,00	44,25	41,75	30,50
M 22 x 2.0	24,60	22,50	22,43	22,73	25,60	26,50	13,60	33,00	42,00	40,00	31,00
M 22 x 1.5	23,95	22,50	22,32	22,56	25,55	26,45	18,10	33,00	39,75	38,25	31,50
M 24 x 3.0	27,90	24,75	24,65	25,05	28,00	29,00	10,00	36,00	49,50	46,50	33,00
M 24 x 2.0	26,60	24,50	24,43	24,73	28,10	29,10	15,00	36,00	45,00	43,00	34,00
M 24 x 1.5	25,95	24,50	24,33	24,56	28,60	29,10	19,80	36,00	42,00	40,50	34,50
M 26 x 1.5	27,95	26,50	26,32	26,56	28,30	28,60	21,80	39,00	45,75	44,25	37,50
M 27 x 1.5	28,95	27,50	27,32	27,65	29,30	29,60	22,80	40,50	47,25	45,75	39,00
M 27 x 2.0	29,60	27,50	27,43	27,73	30,00	30,40	17,00	40,50	49,50	47,50	38,30
M 27 x 3.0	30,90	27,75	27,65	28,05	31,30	31,70	11,25	40,50	54,00	51,00	37,50
M 28 x 1.5	29,95	28,50	28,32	28,56	30,30	30,70	23,50	42,00	48,75	47,25	40,50
M 30 x 1.5	31,95	30,50	30,32	30,56	32,30	32,70	25,50	45,00	51,75	50,25	43,50
M 30 x 2.0	32,60	30,50	30,43	30,73	33,00	33,40	19,10	45,00	54,00	52,00	43,00
M 30 x 3.5	34,55	31,00	30,75	31,21	35,00	35,40	11,00	45,00	60,75	57,25	41,50
M 33 x 2.0	35,60	33,50	33,43	33,73	36,00	36,40	21,10	49,50	58,50	56,50	47,50
M 33 x 3.5	37,55	34,00	33,76	34,21	38,00	38,40	12,35	49,50	65,25	61,75	46,00
M 36 x 1.5	37,95	36,50	36,32	36,56	38,35	38,75	27,25	54,00	60,75	59,25	52,50
M 36 x 2.0	38,60	36,50	36,43	36,73	39,00	39,40	23,25	54,00	63,00	61,00	52,00
M 36 x 3.0	39,90	37,00	36,65	37,05	40,50	41,00	15,25	54,00	67,50	64,50	51,00
M 36 x 4.0	41,20	37,00	36,87	37,34	41,70	42,30	12,60	54,00	72,00	68,00	50,00

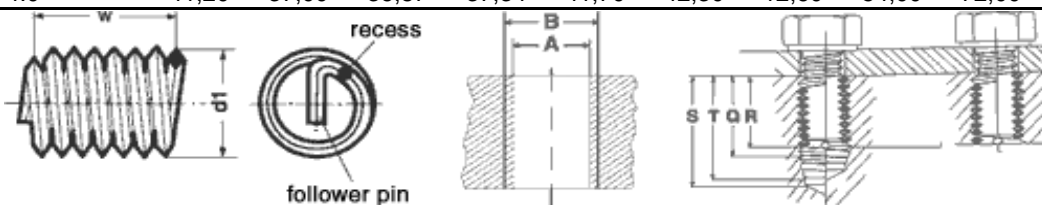

SWEBOLT AB

TEL 08 - 555 976 00 FAX 08 - 583 581 82

TEKNISK DATA

V-COIL GÄNGINSATSER DIN 8140

UNC GÄNGA STIGNING	B mm	C mm	A		d1		W	Q	S	T	R
			MIN mm	MAX mm	MIN mm	MAX mm					
No. 2 x 56	2,84	2,4	0,090	0,096	0,106	0,114	5,25	0,130	0,232	0,191	0,114
No. 4 x 40	3,67	3,00	0,118	0,122	0,144	0,159	4,70	0,168	0,280	0,255	0,143
No. 6 x 32	4,54	3,70	0,145	0,150	0,178	0,193	4,70	0,207	0,348	0,316	0,176
No. 8 x 32	5,11	4,40	0,171	0,175	0,205	0,220	6,00	0,246	0,387	0,355	0,215
No. 10 x 24	6,20	5,10	0,199	0,205	0,244	0,259	5,00	0,285	0,472	0,431	0,243
No. 12 x 24	6,86	5,70	0,225	0,230	0,270	0,285	5,90	0,324	0,511	0,470	0,282
1/4 x 20	8,00	6,70	0,261	0,270	0,310	0,330	5,70	0,375	0,600	0,550	0,325
5/16 x 18	9,77	8,30	0,325	0,334	0,380	0,400	6,60	0,469	0,718	0,663	0,413
3/8 x 16	11,59	9,90	0,389	0,398	0,452	0,472	7,20	0,562	0,844	0,781	0,500
7/16 x 14	13,47	11,60	0,453	0,463	0,526	0,551	7,40	0,656	0,977	0,906	0,585
1/2 x 13	15,23	13,00	0,517	0,527	0,597	0,622	7,90	0,750	1,096	1,019	0,673
9/16 x 12	17,04	14,80	0,581	0,591	0,669	0,694	8,30	0,844	1,219	1,135	0,760
5/8 x 11	18,87	16,50	0,645	0,656	0,742	0,767	9,30	0,937	1,347	1,256	0,847
3/4 x 10	22,35	19,75	0,772	0,783	0,881	0,906	9,40	1,125	1,575	1,475	1,025
7/8 x 9	25,89	23,00	0,899	0,912	1,022	1,052	10,00	1,312	1,812	1,701	1,201
1" x 8	29,52	26,00	1,027	1,042	1,166	1,196	10,20	1,500	2,062	1,937	1,375
1.1/8 x 7	33,29	29,50	1,156	1,171	1,327	1,343	9,90	1,687	2,330	2,115	1,618
1.1/4 x 7	36,46	33,00	1,281	1,296	1,457	1,472	11,25	1,875	2,518	2,303	1,803
1.3/8 x 6	40,42	36,00	1,411	1,431	1,610	1,630	10,50	2,062	2,812	2,645	1,980
1.1/2 x 6	43,60	39,50	1,536	1,556	1,736	1,756	11,50	2,250	3,000	2,883	2,169

UNF GÄNGA STIGNING	B mm	C mm	A		d1		W	Q	S	T	R
			MIN mm	MAX mm	MIN mm	MAX mm					
No. 4 x 40	3,53	3,00	0,117	0,120	0,147	0,162	5,60	0,168	0,262	0,241	0,147
No. 6 x 32	4,33	3,70	0,144	0,148	0,173	0,193	6,00	0,207	0,319	0,294	0,182
No. 8 x 36	5,08	4,40	0,170	0,174	0,204	0,224	6,60	0,246	0,371	0,343	0,218
No. 10 x 32	5,86	5,10	0,197	0,201	0,236	0,256	6,80	0,285	0,426	0,394	0,254
1/4 x 28	7,53	6,60	0,258	0,264	0,306	0,326	8,10	0,375	0,536	0,500	0,339
5/16 x 24	9,31	8,20	0,322	0,328	0,380	0,400	8,90	0,469	0,656	0,614	0,427
3/8 x 24	10,90	9,80	0,384	0,390	0,448	0,468	10,90	0,562	0,750	0,708	0,521
7/16 x 20	12,76	11,50	0,449	0,456	0,524	0,549	10,60	0,656	0,881	0,831	0,606
1/2 x 20	14,35	13,00	0,511	0,518	0,592	0,617	12,30	0,750	0,975	0,925	0,700
9/16 x 18	16,12	14,80	0,575	0,582	0,666	0,691	12,50	0,844	1,093	1,038	0,789
5/8 x 18	17,70	16,25	0,637	0,644	0,733	0,758	14,10	0,937	1,187	1,132	0,882
3/4 x 16	21,11	19,50	0,764	0,771	0,876	0,901	15,10	1,125	1,406	1,344	1,062
7/8 x 14	24,58	23,00	0,891	0,899	1,021	1,051	15,40	1,312	1,634	1,562	1,241
1" x 12	28,15	26,00	1,018	1,028	1,169	1,199	15,10	1,500	1,875	1,792	1,417
1.1/8 x 12	31,33	29,00	1,143	1,154	1,250	1,264	17,50	1,687	2,062	1,979	1,604
1.1/4 x 12	34,50	32,50	1,268	1,279	1,378	1,394	19,60	1,875	2,250	2,167	1,792
1.3/8 x 12	37,68	35,50	1,393	1,404	1,504	1,520	21,60	2,062	2,438	2,354	1,979
1.1/2 x 12	40,85	38,50	1,518	1,529	1,630	1,646	23,75	2,250	2,625	2,542	2,167

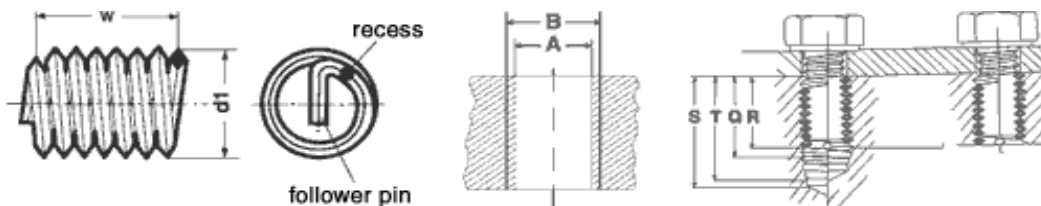

C = Borrdiameter

SWEBOLT AB
TEL 08 - 555 975 00 FAX 08 - 583 581 82

TEKNISK DATA

V-COIL GÄNGINSATSER DIN 8140

BSW GÄNGA STIGNING	B mm	C mm	A		d1		W	Q	S	T	R
			MIN mm	MAX mm	MIN mm	MAX mm					
1/4 x 20	7,80	6,7	0,261	0,267	0,311	0,331	5,9	0,375	0,600	0,550	0,325
5/16 x 18	9,60	8,3	0,328	0,334	0,382	0,401	6,7	0,469	0,718	0,663	0,413
3/8 x 16	11,40	9,9	0,390	0,398	0,453	0,472	7,3	0,562	0,844	0,781	0,500
7/16 x 14	13,20	11,6	0,453	0,463	0,531	0,551	7,5	0,656	0,977	0,906	0,585
1/2 x 12	15,20	13,0	0,515	0,525	0,606	0,630	7,3	0,750	1,125	1,042	0,667
9/16 x 12	16,80	14,8	0,578	0,588	0,669	0,669	8,4	0,844	1,219	1,135	0,760
5/8 x 11	18,60	16,7	0,653	0,663	0,744	0,767	8,7	0,937	1,347	1,256	0,847
3/4 x 10	22,00	20,0	0,781	0,791	0,882	0,905	9,7	1,125	1,575	1,475	1,025
7/8 x 9	25,50	23,0	0,906	0,916	1,024	1,051	10,1	1,312	1,812	1,701	1,201
1" x 8	29,10	26,5	1,031	1,044	1,090	1,197	10,3	1,500	2,062	1,937	1,375

BSF GÄNGA STIGNING	B mm	C mm	A		d1		W	Q	S	T	R
			MIN mm	MAX mm	MIN mm	MAX mm					
1/4 x 26	7,50	6,6	0,257	0,264	0,311	0,33	7,6	0,375	0,548	0,510	0,336
5/16 x 22	9,30	8,3	0,323	0,330	0,386	0,41	8,1	0,469	0,673	0,629	0,423
3/8 x 20	11,00	9,9	0,385	0,392	0,457	0,48	9,0	0,562	0,787	0,737	0,512
7/16 x 18	12,80	11,6	0,450	0,458	0,535	0,56	9,5	0,656	0,906	0,851	0,601
1/2 x 16	14,60	13,0	0,510	0,522	0,610	0,63	9,7	0,750	1,031	0,969	0,687
9/16 x 16	16,20	14,8	0,577	0,586	0,677	0,70	11,1	0,844	1,125	1,062	0,781
5/8 x 14	18,00	16,4	0,640	0,649	0,752	0,78	10,8	0,937	1,259	1,187	0,866
3/4 x 12	21,50	19,5	0,765	0,775	0,902	0,93	11,1	1,125	1,500	1,412	1,042
7/8 x 11	24,90	22,7	0,890	0,900	1,043	1,08	11,9	1,312	1,722	1,631	1,222
1" x 10	28,40	26,5	1,031	1,044	1,189	1,22	12,5	1,500	1,950	1,850	1,4

G/R GÄNGA STIGNING	B mm	C mm	A		d1		W	Q	S	T	R
			MIN mm	MAX mm	MIN mm	MAX mm					
1/8 x 28	10,82	10,00	9,90	10,16	11,10	11,40	3,80	4,76	8,64	7,94	3,65
1/4 x 19	14,74	13,60	13,46	13,72	15,05	15,35	5,50	9,50	15,54	14,20	8,20
3/8 x 19	18,25	17,10	17,00	17,27	18,55	18,85	8,75	14,30	20,29	18,97	12,94
1/2 x 14	23,09	21,50	21,33	21,60	23,40	23,70	8,60	19,10	27,20	25,40	17,25
5/8 x 14	25,05	23,40	23,24	23,55	25,35	25,65	11,00	23,80	31,95	30,15	21,99
3/4 x 14	28,59	27,00	26,75	27,07	28,90	29,20	13,50	28,60	36,72	34,92	26,77
7/8 x 14	32,35	30,60	30,48	30,81	32,75	33,15	15,80	33,30	41,50	39,67	31,53
1" x 11	35,96	33,70	33,53	33,90	36,40	36,80	14,10	38,10	49,49	46,18	35,79

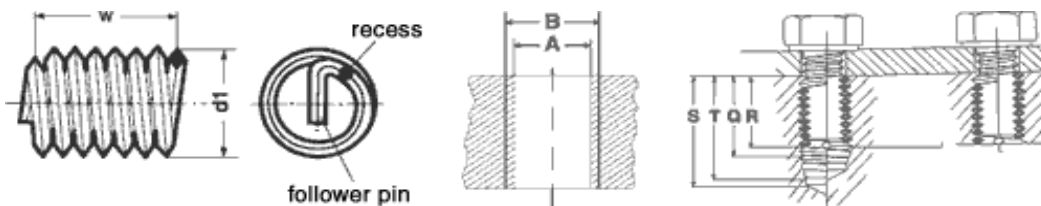

C = Borrdiameter

SWEBOLT AB

TEL 08 - 555 975 00 FAX 08 - 583 581 82

DIN - ORDNING

4	11020	KP, KONISK PINNE	1	2339	STÅL		11:4
4	11021	KP, KONISK PINNE	1	2339	STÅL	HÄRDAD	11:5
4	11020	KP, KONISK PINNE	1	2339	A2		11:44
4	11021	KP, KONISK PINNE	1	2339	A4		11:44
1	11000	CP, CYL. PINNE	h8	7	2338	STÅL	11:1
1	11001	CP, CYL. PINNE	m6	7	2338	STÅL	11:1
1	11002	CP, CYL. PINNE	h6	7	2338	STÅL	11:3
1	11001	CP, CYL. PINNE	m6	7	2338	A2	11:42
1	11002	CP, CYL. PINNE	h8	7	2338	A1	11:42
1	11003	CP, CYL. PINNE	m6	7	2338	A4	11:43
1	11004	CP, CYL. PINNE	h8	7	2338	A4	11:43
1	7000	MCS, CYL. SKALLE	84	1207	4.8	OBEH.	7:1
1	7001	MCS, CYL. SKALLE	84	1207	4.8	FZB	7:1
1	7003	MCS, CYL. SKALLE	84	1207	8.8	FZB	7:2
1	7000	MCS, CYL. SKALLE	84	1207	A2		7:41
1	7001	MCS, CYL. SKALLE	84	1207	A4		7:41
1	7000	MCS, CYL. SKALLE	84	1207			7:60
1	7001	MCS, CYL. SKALLE	84	1207		FÖRNICKLAD	7:60
1	7000	MCS, CYL. SKALLE	84	1207			7:80
1	7000	MCS, CYL. SKALLE	84	1207			7:70
13	7140	MCS Z4, OFÖRLORBAR LÅSBR.	84	Z4/6905	4.8	FZB	7:16
12	7130	MCS Z1, OFÖRLORBAR BR.	84	Z1/6902A	4.8	FZB	7:16
4	7031	MSCS, STOR CYL SKALLE	85	1580	4.8	FZB	7:7
4	7033	MSCS, STOR CYL SKALLE	85	1580	8.8	FZB	7:8
4	7030	MSCS, STOR CYL. SKALLE	85	1580	A2		7:51
4	7031	MSCS, STOR CYL. SKALLE	85	1580	A4		7:52
4	7030	MSCS, STOR CYL. SKALLE	85	1580			7:63
4	7031	MSCS, STOR CYL. SKALLE	85	1580		FÖRNICKLAD	7:63
4	7030	MSCS, STOR CYL. SKALLE	85	1580			7:81
22	4190	LB1, LÅSBLECK m. 1 LÄPP	93			OBEH.	4:14
22	4191	LB1, LÅSBLECK m. 1 LÄPP	93			FZB	4:14
22	4190	LB1, LÅSBLECK m. 1 LÄPP	93		A2		4:42
22	4191	LB1, LÅSBLECK m. 1 LÄPP	93		A4		4:42
1	14000	SP, SAXPINNE	94	1234		OBEH.	14:1
1	14001	SP, SAXPINNE	94	1234		FZB	14:1
1	14000	SP, SAXPINNE	94	1234	A2		14:41
1	14001	SP, SAXPINNE	94	1234	A4		14:42
3	9010	TKFS, KULLERFÖRSÄNK	95			OBEH.	9:6
3	9011	TKFS, KULLERFÖRSÄNK	95			FZB	9:6
3	9010	TKFS, KULLERFÖRSÄNK	95		A2		9:53
3	9011	TKFS, KULLERFÖRSÄNK	95		A4		9:54
3	9011	TKFS, KULLERFÖRSÄNK	95				9:60
3	9012	TKFS, KULLERFÖRSÄNK	95			FÖRNICKLAD	9:60
1	9000	TKS, KULLRIG SKALLE	96			OBEH.	9:6
1	9001	TKS, KULLRIG SKALLE	96			FZB	9:6
1	9000	TKS, KULLRIG SKALLE	96		A2		9:53
1	9001	TKS, KULLRIG SKALLE	96		A4		9:54
1	9000	TKS, KULLRIG SKALLE	96				9:60
1	9001	TKS, KULLRIG SKALLE	96			FÖRNICKLND	9:60
2	9005	TFS, FÖRSÄNK	97			OBEH.	9:6
2	9006	TFS, FÖRSÄNK	97			FZB	9:6
2	9005	TFS, FÖRSÄNK	97		A2		9:53
2	9006	TFS, FÖRSÄNK	97		A4		9:54
2	9005	TFS, FÖRSÄNK	97				9:60
2	9006	TFS, FÖRSÄNK	97			FÖRNICKLAD	9:60
3	13002	KNL, KULLRIG NIT, LÅG	124		STÅL	OBEH.	13:102
1	4003	RB, PLANBRICKA	125A	7089	HV200	OBEH.	4:1

SWEBOLT AB

TEL. 08-584 909 60 FAX. 08-583 581 82

BILD	ART.GR.	BENÄMNING	DIN	ISO	KVAL	YTBEH	SIDA
1	4004	RB, PLANBRICKA	125A	7089	HV200	FZB	4:1
1	4005	RB, PLANBRICKA	125A	7089	HV200	FZV	4:1
1	4006	RB, PLANBRICKA	125		HV140	OBEH.	4:1
1	4007	RB, PLANBRICKA	125		HV140	FZB	4:1
1	4008	RB, PLANBRICKA	125		HV140	FZV	4:1
1	4009	HRB, PLANBRICKA	125A	7089	HV300	OBEH.	4:1
1	4010	HRB, PLANBRICKA	125A	7089	HV300	FZB	4:1
1	4000	BRB, PLANBRICKA	125	7089	A2		4:40
1	4001	BRB, PLANBRICKA	125	7089	A4		4:40
1	4000	RB, PLANBRICKA	125A+B	7089/7090			4:60
1	4001	RB, PLANBRICKA	125A+B	7089/7090		FÖRNICKLAD	4:60
1	4000	PB, PLANBRICKA	125	7089			4:90
1	4000	RB, PLANBRICKA	125	7089			4:70
1	4000	RB, PLANBRICKA	125	7089			4:80
1	4000	RB, PLANBRICKA	125A	7089			4:110
1	4000	RB, PLANBRICKA	125A	7089			4:116
1	4032	SRB, PLANBRICKA	126	7091	HV140	OBEH.	4:2
1	4033	SRB, PLANBRICKA	126	7091	HV140	FZB	4:2
1	4034	SRB, PLANBRICKA	126	7091	HV140	FZV	4:2
11	4140	FBB, FJÄDERBRICKA	127B			OBEH.	4:5
11	4141	FBB, FJÄDERBRICKA	127B			FZB	4:5
11	4142	FBB, FJÄDERBRICKA	127B			FZV	4:5
11	4140	FBB, FJÄDERBRICKA	127B		A2		4:41
11	4141	FBB, FJÄDERBRICKA	127B		A4		4:41
11	4140	FBB, FJÄDERBRICKA	127				4:72
11	4140	FBB, FJÄDERBRICKA	~127				4:81
11	4140	FBB, FJÄDERBRICK	127				4:120
12	4145	FBH, FJÄDERBRICKA	128A			OBEH.	4:5
12	4146	FBH, FJÄDERBRICKA	128A			FZB	4:5
12	4145	FBH, FJÄDERBRICKA	128A		A2		4:48
12	4146	FBH, FJÄDERBRICKA	128A		A4		4:48
13	4150	KBA, KUPAD BRICKA	137A			OBEH.	4:6
13	4151	KBA, KUPAD BRICKA	137A			FZB	4:6
13	4150	KBA, KUPAD BRICKA	137A		A2		4:41
13	4151	KBA, KUPAD BRICKA	137A		A4		4:41
13	4150	KBA, KUPAD BRICKA	137A				4:72
13	4150	KBB, KUPAD BRICKA	137A				4:120
14	4155	KBB, KUPAD BRICKA	137B			OBEH.	4:6
14	4156	KBB, KUPAD BRICKA	137B			FZB	4:6
14	4155	KBB, KUPAD BRICKA	137B		A2		4:48
14	4156	KBB, KUPAD BRICKA	137B		A4		4:48
14	4155	KBB, KUPAD BRICKA	137B				4:72
29	15650	EPOMIX, TUB	160ml				15:2
27	10210	HS, HAMMARSKRUV	186		4.6	OBEH.	10:25
27	10211	HS, HAMMARSKRUV	186		4.6	FZB	10:25
27	10210	HS, HAMMARSKRUV	186		A2		10:45
27	10211	HS, HAMMARSKRUV	186		A4		10:45
5	6110	MVHGS, VARMHÅLLF. GÄNGST.	ASTM. A 193B7			OBEH.	6:5
5	6111	MVHPS, VARMHÅLLF. PINNSKR.	ASTM..A 193B7			OBEH.	6:5
30	62023	GÄNGSNITT, M, GROVGÄNGA	223				18:50
6	11040	GKP, GÄNG KONISK PINNE	258				11:7
12	3200	MVM, VINGMUTTER ADDUC	315			OBEH.	3:10
12	3201	MVM, VINGMUTTER ADDUC	315			FZB	3:10
12	3200	VM, VINGMUTTER ADDUC	315			OBEH.	3:51
12	3201	VM, VINGMUTTER ADDUC	315			FÖRNICKLAD	3:51
12	3200	VM, VINGMUTTER	315				3:91
28	10220	VS, VINGSKRUV	316			OBEH.	10:5
28	10221	VS, VINGSKRUV	316			FZB	10:5
28	10220	VS, VINGSKRUV, AM-TYP	316		A2		10:44
28	10221	VS, VINGSKRUV, AM-TYP	316		A4		10:44

SWEBOLT AB

TEL. 08-584 909 60 FAX. 08-583 581 82

BILD	ART.GR.	BENÄMNING	DIN	ISO	KVAL	YTBEH	SIDA
28	10220	VS, VINGSKRUV	316				10:62
28	10221	VS, VINGSKRUV	316			FÖRNICKLAD	10:62
28	10220	VS, VINGSKRUV	316				10:70
20	62100	DUBBHÅLSBORR, Nr. 210	333R	2541	STÅL	HSS	18:27
13	61000	BORR, CYLINDRISK, Nr. 100	338	235/1	STÅL	HSS	18:20
17	61100	BORR, LÅNG, Nr. 110	340		STÅL	HSS	18:25
14	61300	BORR, KONISK, Nr. 130	345	235/1	STÅL	HSS	18:22
29	15651	EPOMIX, TUB	360ml				15:2
20	7210	SXH, SPÅRSKRUV m. KRYSSHÅL	404			OBEH.	7:20
20	7211	SXH, SPÅRSKRUV m. KRYSSHÅL	404			FZB	7:20
18	7190	TSS, TAPP m. SPÅR	417	7435		OBEH.	7:14
18	7191	TSS, TAPP m.SPÅR	417	7435		FZB	7:14
18	7190	TSS, TAPP m. SPÅR	417	7435	A2		7:55
18	7191	TSS, TAPP m. SPÅR	417	7435	A4		7:55
21	7220	LP, LÅSPINNE m. SPÅR	427	2342		OBEH.	7:17
21	7221	LP, LÅSPINNE m. SPÅR	427	2342		FZB	7:17
1	3060	RM6M, RÖRGÅNGA	431		6	OBEH.	3:33
1	3061	RM6M, RÖRGÅNGA	431		6	FZB	3:33
1	3060	RML6M, RÖRGÅNGA	431		A2		3:49
1	3061	RML6M, RÖRGÅNGA	431		A4		3:49
24	4200	LBUL, LÅSBLECK UTV. LÄPP	432			OBEH.	4:14
24	4201	LBUL, LÅSBLECK UTV. LÄPP	432			FZB	4:14
24	4200	LBUL, LÅSBLECK UTV. LÄPP	432		A2		4:42
24	4201	LBUL, LÅSBLECK UTV. LÄPP	432		A4		4:42
1	4050	PB, PLANBRICKA	433				4:91
2	4050	PB, PLANBRICKA	433	7092	HV250	OBEH.	4:9
2	4051	PB, PLANBRICKA	433	7092	HV250	FZB	4:9
2	4053	PB-FRP, PLANBRICKA FÖR FRP	433	7092	A2		4:44
2	4054	PB-FRP, PLANBRICKA FÖR FRP	433	7092	A4		4:44
2	4050	PB, PLANBRICKA	433	7092			4:61
2	4051	PB, PLANBRICKA	433	7092		FÖRNICKLAD	4:61
7	4115	UBB, U-BALKSBRICKA, 8%	434			OBEH.	4:11
7	4116	UBB, U-BALKSBRICKA, 8%	434			FZB	4:11
7	4117	UBB, U-BALKSBRICKA, 8%	434			FZV	4:11
7	4115	UBB, U-BALKSBRICKA, 8%	434		A2		4:47
7	4116	UBB, U-BALKSBRICKA, 8%	434		A4		4:47
7	4120	UB14, U-BALKSBRICKA, 14%	435			OBEH.	4:11
7	4121	UB14, U-BALKSBRICKA, 14%	435			FZB	4:11
7	4122	UB14, U-BALKSBRICKA, 14 %	435			FZV	4:11
7	4120	UB14, U-BALKSBRICKA, 14%	435		A2		4:47
7	4121	UB14, U-BALKSBRICKA, 14%	435		A4		4:47
6	4100	S4B, FYRKANTBRICKA	436			OBEH.	4:8
6	4101	S4B, FYRKANTBRICKA	436			FZB	4:8
6	4102	S4B, FYRKANTBRICKA	436			FZV	4:8
6	4100	S4B, FYRKANTBRICKA	436		A2		4:46
6	4101	S4B, FYRKANTBRICKA	436		A4		4:46
19	7200	SKSS, SKÅLAD m. SPÅR	438	7436		OBEH.	7:14
19	7201	SKSS, SKÅLAD m. SPÅR	438	7436		FZB	7:14
19	7200	SKSS, SKÅLAD m. SPÅR	438	7436	A2		7:55
19	7201	SKSS, SKÅLAD m. SPÅR	438	7436	A4		7:55
2	3085	ML6M, LÅG SEXKANTMUTTER	439B	4035	6	OBEH.	3:5
2	3086	ML6M, LÅG SEXKANTMUTTER	439B	4035	6	FZB	3:5
2	3087	ML6M, LÅG SEXKANTMUTTER	439B	4035	6	FZV	3:5
2	3085	ML6M, LÅGMUTTER	439	4035	A2		3:40
2	3086	FML6M, LÅGMUTTER, FING.	439	4035	A4		3:40
2	3085	ML6M, LÅG SEXKANTMUTTER	439B	4035		OBEH.	3:52
2	3086	ML6M, LÅG SEXKANTMUTTER	439B	4035		FÖRNICKLAD	3:52
2	4250	TRB, FÖR TRÄKONSTR.	440R			OBEH.	4:17
2	4251	TRB, FÖR TRÄKONSTR.	440R			FZB	4:17
33	4253	RB4, BRICKA m. 4-KANTHÅL	440V			OBEH.	4:17

SWEBOLT AB

TEL. 08-584 909 60 FAX. 08-583 581 82

BILD	ART.GR.	BENÄMNING	DIN	ISO	KVAL	YTBEH	SIDA
33	4254	RB4, BRICKA m. 4-KANTHÅL	440V			FZB	4:17
27	4215	RFB, FÖRSLUTNINGSBR. RAK	443 A			OBEH.	4:16
27	4216	RFB, FÖRSLUTNINGSBR. RAK	443 B			OBEH.	4:16
27	4220	KFB, FÖRSLUTNINGSBR. KONISK	443 A			OBEH.	4:16
27	4221	KFB, FÖRSLUTNINGSBR. KONISK	443 B			OBEH.	4:16
27	4215	RFB, FÖRSLUTNINGSBRICKA RAK	443A		A2		4:50
26	10200	LS, LÄNKSKRUV	444 A,B,C		4.6	OBEH.	10:22
26	10201	LS, LÄNKSKRUV	444 A,B,C		4.6	FZB	10:22
26	10203	LS, LÄNKSKRUV	444 A,B,C		8.8	OBEH.	10:23
26	10204	LS, LÄNKSKRUV	444 A,B,C		8.8	FZB	10:23
26	10200	LS, LÄNKSKRUV	444 B		A2		10:45
26	10201	LS, LÄNKSKRUV	444 B		A4		10:45
25	4205	LBIL, LÅSBLECK INV. LÄPP	462			OBEH.	4:15
25	4206	LBIL, LÅSBLECK INV. LÄPP	462			FZB	4:15
23	4195	LB2, LÅSBLECK m. 2 LÄPPAR	463			OBEH.	4:14
23	4196	LB2, LÅSBLECK m. 2 LÄPPAR	463			FZB	4:14
23	4196	LB2, LÅSBRICKA 2-LÄPP	463		A4		4:42
25	10180	LETTERSKRUV m. ANSATS	464		5.8	OBEH.	10:6
25	10181	LETTERSKRUV m. ANSATS	464		5.8	FZB	10:6
26	3255	RM, RUND LÄTTRAD MUTTER	466			OBEH.	3:23
26	3256	RM, RUND LÄTTRAD MUTTER	466			FZB	3:23
26	3255	RM, RUND LÄTTRAD MUTTER	466		A2		3:45
26	3256	RM, RUND LÄTTRAD MUTTER	466		A4		3:45
26	3255	RM, RUND LÄTTRAD MUTTER	466			OBEH.	3:55
26	3256	RM, RUND LÄTTRAD MUTTER	466			FÖRNICKLAD	3:55
26	3255	RM, RUND LÄTTRAD MUTTER	466				3:91
27	3260	LRM, LÅG RUND LÄTTRAD MU.	467			OBEH.	3:23
27	3261	LRM, LÅG RUND LÄTTRAD MU.	467			FZB	3:23
27	3260	LRM, LÅG RUND LÄTTRAD MU.	467		A1		3:45
27	3261	LRM, LÅG RUND LÄTTRAD MU.	467		A4		3:45
27	3260	LRM, LÅG R. LÄTTRAD MUTTER	467			OBEH.	3:55
27	3261	LRM, LÅG R. LÄTTRAD MUTTER	467			FÖRNICKLAD	3:55
27	3260	LRM, LÅG RUND LÄTTRAD MU.	467				3:91
28	4225	EB, ENDBRICKA	470			OBEH.	4:17
28	4226	EB, ENDBRICKA	470			FZB	4:17
1	5000	SGA, LÅSRING, AXEL	471			OBEH.	5:1
1	5001	SGA, LÅSRING, AXEL	471			MFZG	5:1
1	5000	SGA, LÅSRING, AXEL	471		A2		5:40
1	5001	SGA, LÅSRING, AXEL	471		A4		5:40
2	5010	SGH, LÅSRING, HÅL	472			OBEH.	5:1
2	5011	SGH, LÅSRING, HÅL	472			MFZG	5:1
2	5010	SGH, LÅSRING, HÅL	472		A2		5:40
2	5011	SGH, LÅSRING, HÅL	472		A4		5:40
21	10140	MSK4F, 4-KANT m. FLÄNS	478		8.8	OBEH.	10:21
21	10142	MSK4F, 4-KANT m. FLÄNS	478		10.9	OBEH.	10:21
22	10150	T4SS, STÄLLSKRUV	479		8.8	OBEH.	10:21
22	10152	T4SS, STÄLLSKRUV	479		10.9	OBEH.	10:21
23	10160	4-KANT m. TAPP OCH FLÄNS	480		8.8	OBEH.	10:21
23	10165	4-KANT m. TAPP OCH FLÄNS	480		10.9	OBEH.	10:21
40	3320	TM, T-SPÄRMUTTER	508			OBEH.	3:24
40	3321	TM, T-SPÄRMUTTER	508			FZB	3:24
28	3265	RMS, RUND SLITSMUTTER	546			OBEH.	3:23
28	3266	RMS, RUND SLITSMUTTER	546			FZB	3:23
28	3265	RMS, RUND SLITSMUTTER	546			OBEH.	3:55
28	3266	RMS, RUND SLITSMUTTER	546			FÖRNICKLAD	3:55
29	3270	RMH, RUNDMU. m. SPÄNT HÅL	547			OBEH.	3:23
29	3271	RMH, RUNDMU. m. SPÄNT HÅL	547			FZB	3:23
30	3275	RMSH, RUNDMU. m. SIDOHÅL	548			OBEH.	3:24
30	3276	RMSH, RUNDMU. m. SIDOHÅL	548			FZB	3:24
16	7170	PSS, PLAN m. SPÅR	551	4766		OBEH.	7:14

SWEBOLT AB

TEL. 08-584 909 60 FAX. 08-583 581 82

BILD	ART.GR.	BENÄMNING	DIN	ISO	KVAL	YTBEH	SIDA
16	7171	PSS, PLAN m. SPÅR	551	4766		FZB	7:14
16	7170	PSS, PLAN m. SPÅR	551	4766	A1		7:54
16	7171	PSS, PLAN m. SPÅR	551	4766	A4		7:54
16	7170	PSS, PLAN m. SPÅR	551	4766			7:65
16	7170	PSS, PLAN m. SPÅR	551	4766			7:81
17	7180	SSS, SPETSIG m. SPÅR	553	7434		OBEH.	7:14
17	7181	SSS, SPETSIG m. SPÅR	553	7434		FZB	7:14
17	7180	SSS, SPETSIG m. SPÅR	553	7434	A1		7:54
17	7181	SSS, SPETSIG m. SPÅR	553	7434	A4		7:54
17	7180	SSS, SPETSIG m. SPÅR	553	7434			7:65
1	3001	M6M, SEXKANTMUTTER	555	4034	6	OBEH.	3:17
1	3002	M6M, SEXKANTMUTTER	555	4034	6	FZB	3:17
1	3003	M6M, SEXKANTMUTTER	555	4034	6	FZV	3:17
1	3001	M6M, SEXKANTMUTTER	555	4034			3:90
16	3220	M4M, FYRKANTMUTTER	557			OBEH.	3:10
16	3221	M4M, FYRKANTMUTTER	557			FZB	3:10
16	3220	M4M, 4-KANTMUTTER	557		A2		3:45
16	3221	M4M, 4-KANTMUTTER	557		A4		3:45
1	1101	M6SH, 6-KANT, HELG.	558	4018	5.8	OBEH.	1:39
1	1102	M6SH, 6-KANT, HELG.	558	4018	5.8	FZB	1:39
10	1260	M6STG, TAPP OCH GÄNGA	561A		8.8	OBEH.	1:52
10	1261	M6STG, TAPP OCH GÄNGA	561A		8.8	FZB	1:52
19	10120	T6SS, STÄLLSKRUV, 6-KANT, TAPP	561B		8.8	OBEH.	10:20
17	3225	ML4M, LÅG FYRKANTMUTTER	562			OBEH.	3:10
17	3226	ML4M, LÅG FYRKANTMUTTER	562			FZB	3:10
17	3225	ML4M	562		A2		3:42
11	1266	M6ST, TAPP	564B		8.8	OBEH.	1:53
11	1267	M6ST, TAPP	564B		8.8	FZB	1:53
4	9020	T6S, 6-KANT TRÄSKRUV	571			OBEH.	9:1
4	9021	T6S, 6-KANT TRÄSKRUV	571			FZB	9:1
4	9022	T6S, 6-KANT TRÄSKRUV	571			FZV	9:1
4	9020	T6S, 6-KANT TRÄSKRUV	571		A2		9:40
4	9021	T6S, 6-KANT TRÄSKRUV	571		A4		9:40
17	10100	LT, LYFTÖGLA, TAPP	580	3266	C15	OBEH.	10:4
17	10101	LT, LYFTÖGLA, TAPP	580	3266	C15	FZB	10:4
17	10102	LT, LYFTÖGLA, TAPP	580	3266	C15	FZV	10:4
17	10105	LT, LYFTÖGLA, TAPP, UNC	580	3266	C15	OBEH.	10:26
17	10106	LT, LYFTÖGLA, TAPP, UNC	580	3266	C15	FZB	10:26
17	10107	LT, LYFTÖGLA, TAPP, UNC	580	3266	C15	FZV	10:26
17	10100	LT, LYFTÖGLA, TAPP	580		A2		10:43
17	10101	LT, LYFTÖGLA, TAPP	580		A4		10:43
18	10110	LH, LYFTÖGLA, HÅL	582		C15	OBEH.	10:4
18	10111	LH, LYFTÖGLA, HÅL	582		C15	FZB	10:4
18	10112	LH, LYFTÖGLA, HÅL	582		C15	FZV	10:4
18	10115	LH, LYFTÖGLA, HÅL, UNC	582		C15	OBEH.	10:26
18	10116	LH, LYFTÖGLA, HÅL, UNC	582		C15	FZB	10:26
18	10117	LH, LYFTÖGLA, HÅL, UNC	582		C15	FZV	10:26
18	10110	LH, LYFTÖGLA, HÅL	582		A2		10:43
18	10111	LH, LYFTÖGLA, HÅL	582		A4		10:43
2	1105	M6S, 6-KANT, HELG.	601	4016	4.6-6.8	OBEH.	1:40
2	1106	M6S, 6-KANT, DELG.	601	4016	4.6-6.8	FZB	1:41
2	1107	M6S, 6-KANT, DELG.	601		4.6	FZV	1:42
1	10001	MVBF, VAGNSBULT	603	8677	4.6	OBEH.	10:1
1	10002	MVBF, VAGNSBULT	603	8677	4.6	FZB	10:1
1	10003	MVBF, VAGNSBULT	603	8677	4.6	FZV	10:7
1	10004	MVBF, VAGNSBULT	603	8677	8.8	OBEH.	10:8
1	10005	MVBF, VAGNSBULT	603	8677	8.8	FZB	10:8
1	10006	MVBF, VAGNSBULT	603	8677	8.8	FZV	10:8
1	10008	UVBF, VAGNSBULT UNC	603		4.6	OBEH.	10:27

SWEBOLT AB

TEL. 08-584 909 60 FAX. 08-583 581 82

BILD	ART.GR.	BENÄMNING	DIN	ISO	KVAL	YTBEH	SIDA
1	10009	UVBF, VAGNSBULT UNC	603		4.6	FZB	10:27
1	10001	MVBF, VAGNSBULT	603	8677	A2		10:41
1	10002	MVBF, VAGNSBULT	603	8677	A4		10:41
1	10001	MVBF, VAGSBULT	603	8677			10:60
2	10010	MVBFFK, FÖRS. m. KNASTER	604		4.6	OBEH.	10:9
2	10011	MVBFFK, FÖRS. m. KNASTER	604		4.6	FZB	10:9
3	10015	MVBFF, FÖRSÄNKT VAGNSBULT	605		4.6	OBEH.	10:10
3	10016	MVBFF, FÖRSÄNKT VAGNSBULT	605		4.6	FZB	10:10
4	10020	MVBFK, VAGNSB. m. KNASTER	607		4.6	OBEH.	10:12
4	10021	MVBFK, VAGNSB. m. KNASTER	607		4.6	FZB	10:12
3	10017	MVBFF, FÖRSÄNKT VAGNSBULT	608		4.6	OBEH.	10:11
3	10018	MVBFF, FÖRSÄNKT VAGNSBULT	608		8.8	OBEH.	10:11
7	1190	M6SPBK, K6, LÅNG GÅNGA	609		8.8	OBEH.	1:57
7	1191	M6SBBL, K6, KORT GÅNGA	610		8.8	OBEH.	1:58
24	10170	LETTERSKRUV	653		5.8	OBEH.	10:6
24	10171	LETTERSKRUV	653		5.8	FZB	10:6
24	10170	LETTERSKRUV	653				10:62
1	13000	KN, KULLRIG NIT	660		STÅL	OBEH.	13:100
1	13000	KN, KULLRIG NIT	660		A2		13:110
1	13000	KN, KULLRIG NIT	660				13:120
1	13000	KN, KULLRIG NIT	660				13:130
1	13000	KN, KULLRIG NIT	660				13:140
4	13010	FN, FÖRSÄNKT NIT	661		STÅL	OBEH.	13:101
4	13010	FN, FÖRSÄNKT NIT	661		A2		13:111
4	13011	FN, FÖRSÄNKT NIT	661		A4		13:111
4	13010	FN, FÖRSÄNKT NIT	661				13:121
4	13010	FN, FÖRSÄNKT NIT	661				13:131
4	13010	FN, FÖRSÄNKT NIT	~661				13:142
5	13015	KFN, KULLERFÖRSÄNKT NIT	662		STÅL	OBEH.	13:104
5	13015	KFN, KULLERFÖRSÄNKT NIT	662				13:122
5	13015	KFN, KULLERFÖRSÄNKT NIT	662				13:132
5	13015	KFN, KULLERFÖRSÄNKT NIT	662				13:143
2	13001	KNH, KULLRIG NIT, HALVRUND	674		STÅL	OBEH.	13:102
2	13001	KNL, KULLRIG NIT, LÅG	674				13:141
5	12040	SR, STÄLLRING m. STOPPSKRUV	705				12:4
5	12040	SR, STÄLLRING m. STOPPSKRUV	705		A2		12:42
13	14340	VAJERLÅS	741			FZB	14:7
13	14341	VAJERLÅS	741			FZV	14:7
13	14340	VAJERLÅS	741		A2		14:45
45	10600	TB, T-SPÅRSBULT	787			FZB	10:36
9	10050	RP 906, KONISK, INV. 6-KANT	906	M+R	5.8	OBEH.	10:2
9	10051	RP 906, KONISK, INV. 6-KANT	906	M+R	5.8	FOS	10:2
9	10052	RP 906, KONISK, INV. 6-KANT	906	M+R	5.8	FZB	10:2
9	10050	RP 906, KONISK, INV. 6-KANT	906	M+R	A2		10:42
9	10051	RP 906, KONISK, INV. 6-KANT	906	M+R	A4		10:42
9	10050	RP-906, KONISK, INV. 6-KANT	906				10:61
10	10055	RP 908, INV. 6-KANT m. FLÄNS	908	M+R	5.8	OBEH.	10:2
10	10056	RP 908, INV. 6-KANT m. FLÄNS	908	M+R	5.8	FOS	10:2
10	10057	RP 908, INV. 6-KANT m. FLÄNS	908	M+R	5.8	FZB	10:2
10	10055	RP 908, INV. 6-KANT m. FLÄNS	908	M+R	A2		10:42
10	10056	RP 908, INV. 6-KANT m. FLÄNS	908	M+R	A4		10:42
10	10055	RP-908, INV. 6-KANT m. FLÄNS	908				10:61
11	10060	RP 908T, FLÄNS OCH TÄTNING	~908	M+R	5.8	OBEH.	10:15
12	10065	RP 910, 6-KANT	910	M+R	5.8	OBEH.	10:2
12	10066	RP 910, 6-KANT	910	M+R	5.8	FOS	10:2
12	10067	RP 910, 6-KANT	910	M+R	5.8	FZB	10:2
12	10065	RP 910, 6-KANT	910	M+R	A2		10:42
12	10066	RP 910, 6-KANT	910	M+R	A4		10:42
12	10065	RP-910, 6-KANT	910				10:61
12	11066	RP-910, 6-KANT	910			FÖRNICKLAD	10:61

SWEBOLT AB

TEL. 08-584 909 60 FAX. 08-583 581 82

BILD	ART.GR.	BENÄMNING	DIN	ISO	KVAL	YTBEH	SIDA
13	10070	RP 910T, 6-KANT m. TÄTNING	~910	M+R	5.8	OBEH.	10:15
14	10075	RP 910M, 6-KANT, MAGNETISK	910	M+R	5.8	OBEH.	10:15
	2134	6KN, 6-KANT-NYCKEL, LÅNG	911			OBEH.	2:31
	2135	6KN, 6-KANT-NYCKEL, LÅNG	911			FZB	2:31
12	2130	6KN, 6-KANT-NYCKEL	911	2936		OBEH.	2:31
12	2131	6KN, 6-KANT-NYCKEL	911	2936		FZB	2:31
12	2132	6KN, 6-KANT-NYCKEL	911		HÄRDAD	OBEH.	2:31
12	2133	6KN, 6-KANT-NYCKEL	911		HÄRDAD	FZB	2:31
1-2	2000	MC6S, INSEXSKRUV	912	4762	8.8	OBEH.	2:1-2
1-2	2001	MC6S, INSEXSKRUV	912	4762	8.8	FZB	2:3-4
1-2	2002	MC6S, INSEXSKRUV	912	4762	8.8	DACROMET	2:7
1-2	2005	MC6S, INSEXSKRUV	912	4762	12.9	OBEH.	2:5-6
1-2	2007	MC6S, INSEXSKRUV	912	4762	10.9	OBEH.	2:10
1-2	2008	MC6S, INSEXSKRUV	912	4762	10.9	FZB	2:11
1-2	2009	MC6S, INSEXSKRUV	912	4762	10.9	DACROMET	2:11
1-2	2013	FMC6S, INSEXSKRUV, FING.	912	4762	8.8	OBEH.	2:9
1-2	2014	FMC6S, INSEXSKRUV, FING.	912	4762	8.8	FZB	2:9
1-2	2015	FMC6S, INSEXSKRUV, FING.	912	4762	12.9	OBEH.	2:12
1-2	2000	MC6S, INSEXSKRUV	912	4762	A2		2:61
1-2	2001	MC6S, INSEXSKRUV	912	4762	A4		2:64
1-2	2005	MC6S, INSEXSKRUV	912	4762	A4-80		2:62
1-2	2014	MC6S, INSEXSKRUV	912	4762	A2	FÖRZINKAD	2:65
1-2	2015	MC6S, INSEXSKRUV	912	4762	A4-80	FÖRZINKAD	2:66
1-2	2000	MC6S, INSEXSKRUV	912	4762			2:84
2	2003	MC6SH, INSEXSKRUV, HELG	912	4762	8.8	OBEH.	2:8
2	2004	MC6SH, INSEXSKRUV, HELG.	912	4762	8.8	FZB	2:8
2	2006	MC6SH, INSEXSKRUV, HELG.	912	4762	12.9	OBEH.	2:12
2	2003	MC6SH, HELGÄNGA	912	4762	A2		2:63
2	2004	MC6SH, HELGÄNGA	912	4762	A4		2:63
8	2080	P6SS, STOPPSKRUV PLAN	913	4026	45HRC	OBEH.	2:27
8	2081	P6SS, STOPPSKRUV PLAN	913	4026	45HRC	FZB	2:29
8	2080	P6SS, STOPPSKRUV PLAN	913	4026	A2		2:73
8	2081	P6SS, STOPPSKRUV PLAN	913	4026	A4		2:74
21	2050	STOPPSKRUV ESLOK, PLAN	913	4026		OBEH.	2:53
9	2090	S6SS, STOPPSKRUV m. SPETS	914	4027	45HRC	OBEH.	2:27
9	2091	S6SS, STOPPSKRUV m. SPETS	914	4027	45HRC	FZB	2:29
9	2090	S6SS, STOPPSKRUV m. SPETS	914	4027	A2		2:73
9	2091	S6SS, STOPPSKRUV m. SPETS	914	4027	A4		2:74
21	2052	STOPPSKRUV ESLOK, SPETS	914	4027		OBEH.	2:53
10	2100	T6SS, STOPPSKRUV m. TAPP	915	4028	45HRC	OBEH.	2:28
10	2101	T6SS, STOPPSKRUV m. TAPP	915	4028	45HRC	FZB	2:30
10	2100	T6SS, STOPPSKRUV m. TAPP	915	4028	A2		2:73
10	2101	T6SS, STOPPSKRUV m. TAPP	915	4028	A4		2:74
21	2054	STOPPSKRUV ESLOK, TAPP	915	4028		OBEH.	2:53
11	2110	SK6SS, STOPPSKRUV SKÅLAD	916	4029	45HRC	OBEH.	2:28
11	2111	SK6SS, STOPPSKRUV SKÅLAD	916	4029	45HRC	FZB	2:30
11	2110	SK6SS, STOPPSKRUV SKÅLAD	916	4029	A2		2:73
11	2111	SK6SS, STOPPSKRUV SKÅLAD	916	4029	A4		2:74
21	2056	STOPPSKRUV ESLOK, SKÅL	916	4029		OBEH.	2:53
10	3185	MLHM, LÅG HATTMUTTER	917		6	OBEH.	3:21
10	3186	MLHM, LÅG HATTMUTTER	917		6	FZB	3:21
10	3187	FMLHM, FING. L. HATTMUTTER	917		6	OBEH.	3:21
10	3188	FMLHM, FING. L.HATTMUTTER	917		6	FZB	3:21
10	3185	MLHM, LÅG HATTMUTTER	917		A2		3:44
10	3186	MLHM, LÅG HATTMUTTER	917		A4		3:44
10	3185	MLHM, LÅG HATTMUTTER	917			OBEH.	3:54
10	3186	MLHM, LÅG HATTMUTTER	917			FÖRNICKLAD	3:54
10	3185	MLHM, LÅG HATTMUTTER	917				3:81
32	7250	ASL, ANSATSSKRUV, LITEN SKA.	920			OBEH.	7:19
22	7230	FLSS, FLATSKALLIG SPÅRSKRUV	921			OBEH.	7:12

SWEBOLT AB

TEL. 08-584 909 60 FAX. 08-583 581 82

BILD	ART.GR.	BENÄMNING	DIN	ISO	KVAL	YTBEH	SIDA
22	7231	FLSS, FLATSKALLIG SPÅRSKRUV	921			FZB	7:12
22	7230	FLSS, FLATSKALLIG SPÅRSKRUV	921				7:66
25	7260	LITEN SKALLE + TAPP	922			OBEH.	7:18
23	7240	AS, ANSATSSKRUV	923			OBEH.	7:17
26	7270	GÄNGAD PINNE MED TAPP	926			OBEH.	7:18
27	7280	TAPPSKRUV	927			OBEH.	7:18
14	3215	SVM4M, SVETSMUTTER 4-KANT	928			OBEH.	3:11
15	3216	SVM6M, SVETSMUTTER 6-KANT	929			OBEH.	3:11
15	3216	SVM6M, SVETSMUTTER	929		A2		3:41
15	3217	SVM6M, SVETSMUTTER	929		A4		3:41
4	1113	M6S, 6-KANT, DELG.	931		8.8	OBEH.	1:3-4
4	1114	M6S, 6-KANT, DELG.	931		8.8	FZB	1:7-8
4	1115	M6S, 6-KANT, DELG.	931		8.8	FZV	1:10
4	1134	M6S, 6-KANT, DELG.	931		10.9	OBEH.	1:13-14
4	1135	M6S, 6-KANT, DELG.	931		10.9	FZB	17:18
4	1139	M6S, 6-KANT, DELG.	931		12.9	OBEH.	1:20
4	1113	M6S, ROSTFRI, DELG.	931		A2		1:72
4	1114	M6S, SYRAFAST, DELG.	931		A4		1:76
4	1115	M6S, SYRAFAST, DELG.	931		A4-80		1:74
4	1131	M6S, ROSTFRI, DELG.	931	4014	A2	FZB	1:84
4	1133	M6S, SYRAFAST, DELG.	931	4014	A4-80	FZB	1:86
4	1110	M6S, 6-KANT, DELG.	931	4014			1:81
4	1111	M6S, 6-KANT, DELG.	931	4014		FÖRNICKLAD	1:82
4	1110	M6S, 6-KANT, DELG.	931	4014			1:87
3	1113	M6SH, 6-KANT, HELG.	933		8.8	OBEH.	1:1-2
3	1114	M6SH, 6-KANT, HELG.	933		8.8	FZB	1:5-6
3	1115	M6SH, 6-KANT, HELG.	933		8.8	FZV	1:9
3	1123	UDDA LÄNGDER HELG.	933		8.8	OBEH.	1:5-6
3	1124	UDDA LÄNGDER HELG.	933		8.8	FZB	1:7-8
3	1125	UDDA LÄNGDER HELG.	933		8.8	FZV	1:9
3	1138	M6SH, 6-KANT, HELG.	933		12.9	OBEH.	1:19
3	1113	M6SH, ROSTFRI, HELG.	933		A2		1:71
3	1114	M6SH, SYRAFAST, HELG.	933		A4		1:75
3	1115	M6SH, SYRAFAST, HELG.	933		A4-80		1:73
3	1123	UDDA LÄNGDER HELG.	933		A2		1:71
3	1124	UDDA LÄNGDER HELG.	933		A4		1:75
3	1125	UDDA LÄNGDER HELG.	933		A4-80		1:73
3	1130	M6SH, ROSTFRI, HELG.	933	4017	A2	FZB	1:83
3	1132	M6SH, SYRAFAST, HELG.	933	4017	A4-80	FZB	1:85
3	1110	M6SH, 6-KANT, HELG.	933	4017			1:81
3	1111	M6SH, 6-KANT, HELG.	933	4017		FÖRNICKLAD	1:82
3	1110	M6SH, 6-KANT, HELG.	933	4017			1:87
3	1110	M6SH, 6-KANT, HELG.	933	4017			1:85
3	1110	M6SH, 6-KANT, HELG.	933	4017			1:86
3	1110	M6SH, 6-KANT, HELG.	933	4017			1:88
4	1128	UDDA LÄNGDER, HELG.	933		10.9	OBEH.	1:11-12
4	1129	UDDA LÄNGDER, HELG.	933		10.9	FZB	1:15-16
9	1250	M6SHSZ, 6-KANT+MEJSELSPÅR	933SZ		5.8	OBEH.	1:51
9	1251	M6SHSZ, 6-KANT+MEJSELSPÅR	933SZ		5.8	FZB	1:51
9	1250	M6SHSZ, 6-KANT+MEJSELSPÅR	933SZ				1:83
1	3010	M6M, SEXKANTMUTTER 0,8d	934		8	OBEH.	3:1
1	3011	M6M, SEXKANTMUTTER 0,8d	934		8	FZB	3:1
1	3012	M6M, SEXKANTMUTTER 0,8d	934		8	FZV	3:1
1	3016	M6M, SEXKANTMUTTER 0,8d	934		10	OBEH.	3:2
1	3017	M6M, SEXKANTMUTTER 0,8d	934		10	FZB	3:2
1	3020	M6M, SEXKANTMUTTER 0,8d	934		12	OBEH.	3:2
1	3022	VM6M, VÄNSTERGÅNGA	934		8	OBEH.	3:2
1	3023	VM6M, VÄNSTERGÅNGA	934		8	FZB	3:2
1	3026	VM6M, VÄNSTERGÅNGA 0,8d	934		10	OBEH.	3:18
1	3030	FM6M, FINGÅNGA	934		8	OBEH.	3:7

SWEBOLT AB

TEL. 08-584 909 60 FAX. 08-583 581 82

BILD	ART.GR.	BENÄMNING	DIN	ISO	KVAL	YTBEH	SIDA
1	3031	FM6M, FINGÄNGA	934		8	FZB	3:7
1	3034	FM6M, FINGÄNGA	934		10	OBEH.	3:7
1	3035	FM6M, FINGÄNGA	934		10	FZB	3:7
1	3037	VFM6M, FING., VÄNSTERG.	934		8	OBEH.	3:18
1	3038	VFM6M, FING., VÄNSTERG.	934		8	FZB	3:18
1	3058	RM6M, RÖRGÄNGA	~934	~4033	6	OBEH.	3:32
1	3010	M6M, SEXKANTMUTTER	934		A2		3:40
1	3011	M6M, SEXKANTMUTTER	934		A4-80		3:40
1	3016	M6M, SEXKANTMUTTER	934	4032	A2	FZB	3:43
1	3017	M6M, SEXKANTMUTTER	934	4032	A4-80	FZB	3:43
1	3010	M6M, SEXKANTMUTTER 0,8d	934			OBEH.	3:51
1	3011	M6M, SEXKANTMUTTER 0,8d	934			FÖRNICKLAD	3:51
1	3010	M6M, SEXKANTMUTTER	934				3:90
1	3010	M6M, SEXKANTMUTTER	934				3:70
1	3010	M6M, SEXKANTMUTTER	934				3:80
1	3010	M6M, SEXKANTMUTTER 0,8d	934				3:95
6	3130	MKM, KRONMUTTER	935		6	OBEH.	3:9
6	3131	MKM, KRONMUTTER	935		6	FZB	3:9
6	3135	MKM, KRONMUTTER	935		8	OBEH.	3:9
6	3136	MKM, KRONMUTTER	935		8	FZB	3:9
6	3140	FMKM, FING. KRONMUTTER	935		8	OBEH.	3:9
6	3141	FMKM, FING. KRONMUTTER	935		8	FZB	3:9
6	3145	MKM, KRONMUTTER	935		10	OBEH.	3:9
6	3130	MKM, KRONMUTTER	935		A2		3:42
6	3131	MKM, KRONMUTTER	935		A4		3:42
6	3130	MKM, KRONMUTTER	935			OBEH.	3:52
2	3065	ML6M, LÅG SEXKANTMUTTER	936		6	OBEH.	3:5
2	3066	ML6M, LÅG SEXKANTMUTTER	936		6	FZB	3:5
2	3067	ML6M, LÅG SEXKANTMUTTER	936		6	FZV	3:5
2	3070	VML6M, LÅG, VÄNSTERG.	936/439B 4035		6	OBEH.	3:5
2	3071	VML6M, LÅG, VÄNSTERG.	936/439B 4035		6	FZB	3:5
2	3075	FML6M, FINGÄNGA	936/439B 4035		6	OBEH.	3:8
2	3076	FML6M, FINGÄNGA	936/439B 4035		6	FZB	3:8
7	3150	MLKM, LÅG KRONMUTTER	937		8	OBEH.	3:20
7	3151	MLKM, LÅG KRONMUTTER	937		8	FZB	3:20
7	3158	FMLKM, LÅG KRONMU., FING.	937		8	OBEH.	3:20
7	3159	FMLKM, LÅG KRONMU., FING.	937		8	FZB	3:20
7	3150	MLKM, LÅG KRONMUTTER	937		A2		3:44
7	3151	MLKM, LÅG KRONMUTTER	937		A4		3:44
2	6030	MPS, PINNSKRUV	938		5.8	OBEH.	6:14
2	6031	MPS, PINNSKRUV	938		5.8	FZB	6:14
2	6032	MPS, PINNSKRUV	938		8.8	OBEH.	6:15
2	6033	MPS, PINNSKRUV	938		8.8	FZB	6:15
2	6034	MPS, PINNSKRUV	938		10.9	OBEH.	6:16
2	6030	MPS, PINNSKRUV	938		A2		6:45
2	6031	MPS, PINNSKRUV	938		A4		6:43
2	6030	MPS, PINNSKRUV	938				6:61
2	6035	MPS, PINNSKRUV	939		5.8	OBEH.	6:16
2	6036	MPS, PINNSKRUV	939		5.8	FZB	6:17
2	6037	MPS, PINNSKRUV	939		8.8	OBEH.	6:18
2	6038	MPS, PINNSKRUV	939		8.8	FZB	6:18
2	6039	MPS, PINNSKRUV	939		10.9	OBEH.	6:19
2	6035	MPS, PINNSKRUV	939		A2		6:46
2	6036	MPS, PINNSKRUV	939		A4		6:44
2	6035	MPS, PINNSKRUV	939				6:61
4	1142	FM6S, DELG., FINGÄNGAD	(960)	8765	10.9	OBEH.	1:28
4	1143	FM6S, DELG., FINGÄNGAD	(960)	8765	10.9	FZB	1:30
4	1145	FM6S, DELG., FINGÄNGAD	(960)	8765	12.9	OBEH.	
3	1142	FM6SH, HELG., FINGÄNGAD	(961)	8676	10.9	OBEH.	1:27
3	1143	FM6SH, HELG., FINGÄNGAD	(961)	8676	10.9	FZB	1:29

SWEBOLT AB

TEL. 08-584 909 60 FAX. 08-583 581 82

BILD	ART.GR.	BENÄMNING	DIN	ISO	KVAL	YTBEH	SIDA
3	1145	FM6SH, HELG., FINGÄNGAD	(961)	8676	12.9	OBEH.	
3	1150	FM6SH, UDDA LÄNGDER, HELG.	961	8676	8.8	OBEH.	1:23
3	1151	FM6SH, UDDA LÄNGDER, HELG.	961	8676	8.8	FZB	1:25
4	1152	FM6SH, UDDA LÄNGDER, HELG.	961	8676	10.9	OBEH.	1:27
4	1153	FM6SH, UDDA LÄNGDER, HELG.	961	8676	10.9	FZB	1:29
2	7010	MFS, FÖRSÄNK	963	2009	4.8	OBEH.	7:3
2	7011	MFS, FÖRSÄNK	963	2009	4.8	FZB	7:3
2	7013	MFS, FÖRSÄNK	963	2009	8.8	FZB	7:4
2	7010	MFS, FÖRSÄNK	963	2009	A2		7:42
2	7011	MFS, FÖRSÄNK	963	2009	A4		7:42
2	7010	MFS, FÖRSÄNK	963	2009			7:61
2	7011	MFS, FÖRSÄNK	963	2009		FÖRNICKLAD	7:61
2	7010	MFS, FÖRSÄNK	963	2009			7:80
2	7010	MFS, FÖRSÄNK	963	2009			7:71
3	7021	MKFS, KULLERFÖRSÄNK	964	2010	4.8	FZB	7:5
3	7020	MKFS, KULLERFÖRSÄNK	964	2010	A2		7:43
3	7021	MKFS, KULLERFÖRSÄNK	964	2010	A4		7:43
3	7020	MKFS, KULLERFÖRSÄNK	964	2010			7:62
3	7021	MKFS, KULLERFÖRSÄNK	964	2010		FÖRNICKLAD	7:62
3	7020	MKFS, KULLERFÖRSÄNK	964	2010			7:81
3	7020	MKFS, KULLERFÖRSÄNK	964	2010			7:71
8	7080	MFV, FÖRSÄNK, PH	965	7046	4.8	OBEH.	7:10
8	7081	MFV, FÖRSÄNK, PH	965	7046	4.8	FZB	7:9
8	7080	MFV, FÖRSÄNK, PH	965	7046	A2		7:45
8	7081	MFV, FÖRSÄNK, PH	965	7046	A4		7:45
9	7091	MFV, FÖRSÄNK, POZI	965	7046	4.8	FZB	7:9
9	7090	MFV, FÖRSÄNK, POZI	965	7046	A2		7:45
9	7091	MFV, FÖRSÄNK, POZI	965	7046	A4		7:45
29	7082	MFT, FÖRSÄNK, STAR	~965	~7046	4.8	OBEH.	7:13
29	7083	MFT, FÖRSÄNK, STAR	~965	~7046	4.8	FZB	7:13
29	7084	MFT, FÖRSÄNK, STAR	~965	~7046	8.8	FZB	7:13
29	7082	MFT, FÖRSÄNK, STAR	~965	~7046	A2		7:48
29	7083	MFT, FÖRSÄNK, STAR	~965	~7046	A4		7:48
10	7111	MKFX, KULLERFÖRSÄNK, PH	966	7047	4.8	FZB	7:10
10	7110	MKFX, KULLERFÖRSÄNK, PH	966	7047	A2		7:46
10	7111	MKFX, KULLERSÖRSÄNK, PH	966	7047	A4		7:46
11	7121	MKFX, KULLERFÖRSÄNK, POZI	966	7047	4.8	FZB	7:10
11	7120	MKFX, KULLERFÖRSÄNK, POZI	966	7047	A2		7:46
11	7121	MKFX, KULLERSÖRSÄNK, POZI	966	7047	A4		7:46
30	7085	MKFT, KULLERFÖRSÄNK, STAR	~966	~7047	A2		7:49
30	7086	MKFT, KULLERFÖRSÄNK, STAR	~966	~7047	A4		7:49
1	3013	M6M, SEXKANTMUTTER 0,9d	970	4032	8	OBEH.	3:1
1	3014	M6M, SEXKANTMUTTER 0,9d	970	4032	8	FZB	3:1
1	3015	M6M, SEXKANTMUTTER 0,9d	970	4032	8	FZV	3:1
1	3018	M6M, SEXKANTMUTTER 0,9d	970	4032	10	OBEH.	3:2
1	3019	M6M, SEXKANTMUTTER 0,9d	970	4032	10	FZB	3:2
1	3021	M6M, SEXKANTMUTTER 0,9d	970	4032	12	OBEH.	3:2
1	3024	VM6M, VÄNSTERGÅNGA 0,9d	970	4032	8	OBEH.	3:18
1	3025	VM6M, VÄNSTERGÅNGA 0,9d	970	4032	8	FZB	3:18
1	3032	FM6M, FINGÄNGA	970	4032	8	OBEH.	3:7
1	3033	FM6M, FINGÄNGA	970	4032	8	FZB	3:7
1	3036	FM6M, FINGÄNGA	970	4032	10	OBEH.	3:7
1	3039	VFM6M, FING., VÄNSTERG.	970	4032	8	OBEH.	3:18
3	6050	MHGS, HELGÄNGAD STÅNG	975		4.6	OBEH.	6:1
3	6051	MHGS, HELGÄNGAD STÅNG	975		4.6	FZB	6:1
3	6052	MHGS, HELGÄNGAD STÅNG	975		4.6	FZV	6:1
3	6053	MHGS, HELGÄNGAD STÅNG	975		5.8	OBEH.	6:2
3	6054	MHGS, HELGÄNGAD STÅNG	975		5.8	FZB	6:2
3	6055	MHGS, HELGÄNGAD STÅNG	975		5.8	FZV	6:2
3	6056	MHGS, HELGÄNGAD STÅNG	975		8.8	OBEH.	6:3

SWEBOLT AB

TEL. 08-584 909 60 FAX. 08-583 581 82

BILD	ART.GR.	BENÄMNING	DIN	ISO	KVAL	YTBEH	SIDA
3	6057	MHGS, HELGÄNGAD STÅNG	975		8.8	FZB	6:3
3	6058	MHGS, HELGÄNGAD STÅNG	975		8.8	FZV	6:3
3	6070	MHGS, HELGÄNGAD STÅNG	975		10.9	OBEH.	6:3
3	6073	MHGS, HELGÄNGAD STÅNG	975		12.9	OBEH.	6:3
3	6050	MHGS, HELGÄNGAD STÅNG	975		A2		6:40
3	6051	MHGS, HELGÄNGAD STÅNG	975		A4		6:40
3	6050	MHGS, HELGÄNGAD STÅNG	975				6:70
3	6050	MHGS, HELGÄNGAD STÅNG	975				6:80
5	6100	MHPS, HELGÄNGAD PINNSKRUV	976		A2		6:41
5	6101	MHPS, HELGÄNGAD PINNSKRUV	976		A4		6:41
5	3120	HLM6M, HELMET. LÅSMUTTER	980	7042	8	OBEH.	3:4
5	3121	HLM6M, HELMET. LÅSMUTTER	980	7042	8	FZB	3:4
5	3122	HLM6M, HELMET. LÅSMUTTER	980	7042	8	FZV	3:4
5	3126	HLM6M, HELMET. LÅSMUTTER	980	7042	10	FZB	3:4
5	3127	FHLM6M, HELMET. FINGÅNGA	980	7042	10	FZB	3:4
5	3120	HLM6M, HELMET. LÅSMUTTER	980		A2		3:42
5	3121	HLM6M, HELMET. LÅSMUTTER	980		A4		3:42
4	3103	LM6MH, NYLONLÅSMU., HÖG	982		8	FZB	3:3
4	3104	LM6MH, NYLONLÅSMU., HÖG	982		10	FZB	3:3
4	3116	FLM6MM, FINGÅNGA, NYLOCK	~982		8	FZB	3:19
4	3103	LM6MH, NYLONLÅSM, HÖG	982		A2		3:44
4	3104	LM6MH, NYLONLÅSM, HÖG	982		A4		3:44
3	5020	AK, LÅSRING m. LÄPP, HÅL	983			OBEH.	5:6
4	5022	SGHL, LÅSRING m. LÄPP, AXEL	984			OBEH.	5:6
3	3100	LM6M, NYLONLÅSMUTTER	985		6-8	FZB	3:3
3	3101	LM6M, NYLONLÅSMUTTER	985		10	FZB	3:3
3	3102	FLM6M, FINGÅNGAD LÅSM.	985		8	FZB	3:8
3	3107	FLM6M, FINGÅNGAD LÅSM.	985		10	FZB	3:8
3	3100	LM6M, NYLONLÅSMUTTER	985		A2		3:40
3	3101	LM6M, NYLONLÅSMUTTER	985		A4-80		3:40
3	3102	LM6M, NYLONLÅSMUTTER	985		A2	FZB	3:43
3	3103	LM6M, NYLONLÅSMUTTER	985		A4	FZB	3:43
3	3100	LM6M, NYLONLÅSMUTTER	985			OBEH.	3:52
3	3101	LM6M, NYLONLÅSMUTTER	985			FÖRNICKLAD	3:52
11	3190	LMHM, HATTM. m. NYLONLÅSR.	986			OBEH.	3:21
11	3191	LMHM, HATTM. m. NYLONLÅSR.	986			FZB	3:21
17	5100	PB, PASSBRICKA, SHIMS	988			OBEH.	5:2
7	6135	M6M2H, VARMHÅLLF. MUTTER	934	ASTM.A 194 Gr 2H		OBEH.	6:5
16	11140	CBH, CYL. SKALLBULT	1434				11:12
17	11150	HCB, CYL. SKALLBULT m. HÅL	1434				11:7
2	4055	PBM, PLANBRICKA MEDEL	1440			OBEH.	4:12
2	4056	PBM, PLANBRICKA MEDEL	1440			FZB	4:12
2	4058	PBG, PLANBRICKA GROV	1441			OBEH.	4:12
2	4059	PBG, PLANBRICKA GROV	1441			FZB	4:12
18	11160	HCP, CYL. PINNE m. TVÅ HÅL	1443				11:13
7	11060	RPC, RÄFFELPINNE	1470	8739			11:8
8	11070	RPA, RÄFFELPINNE	1471	8744			11:8
9	11080	RPB, RÄFFELPINNE	1472	8745			11:8
10	11090	RP, RÄFFELPINNE	1473	8740			11:9
11	11100	RPE, RÄFFELPINNE	1474	8741			11:9
12	11110	RPD, RÄFFELPINNE	1475	8742			11:9
31		KNR, RÄFFLAD KULLRIG NIT	1476		STÅL		13:106
32	13040	KNR, KULLRIG NIT, RÄFFLAD	1476	8746			
32		FNR, RÄFLAD FÖRSÄNKT NIT	1477		STÅL		13:107
25	14500	SPÄNNMUTTER	1479			OBEH.	14:13
25	14501	SPÄNNMUTTER	1479			FZB	14:13
25	14502	SPÄNNMUTTER	1479			FZV	14:13
26	14520	VANTSKRUV, HYLSA	1480				14:14
26	14521	VANTSKRUV m. PINNBULT	1480				14:14
27	14522	VANTSKRUV m. ÖGELBULT	1480				14:14

SWEBOLT AB

TEL. 08-584 909 60 FAX. 08-583 581 82

BILD	ART.GR.	BENÄMNING	DIN	ISO	KVAL	YTBEH	SIDA
28	14523	VANTRUKURV m. ÖGLA+HAKK	1480				14:15
29	14524	VANTRUKURV m. HAKK	1480				14:15
13	11120	FRP, FJÄDRANDE RÖRPINNE	1481	8752			11:3-11:4
13	11120	FRP, FJÄDRANDE RÖRPINNE	1481	8752	A2		11:41
8	3170	MHM, HATTMUTTER	1587		6	OBEH.	3:10
8	3171	MHM, HATTMUTTER	1587		6	FZB	3:10
8	3172	FMHM, FING. HATTMUTTER	1587			OBEH.	3:21
8	3173	FMHM, FING. HATTMUTTER	1587			FZB	3:21
8	3170	MHM, HATTMUTTER	1587		A2		3:41
8	3171	MHM, HATTMUTTER	1587		A4		3:41
8	3170	MHM, HATTMUTTER	1587			OBEH.	3:51
8	3171	MHM, HATTMUTTER	1587			FÖRNICKLAD	3:51
8	3172	MHM, HATTMUTTER	1587			FÖRKROMAD	3:51
8	3170	MHM, HATTMUTTER	1587				3:90
8	3170	MHM, HATTMUTTER	1587				3:80
9	3182	MHMP, HATTMU., PLÅTKAPSEL	~1587			OBEH.	3:21
9	3183	MHMP, HATTMU., PLÅTKAPSEL	~1587			FZB	3:21
47	3280	KM, KULLAGERLÅSMUTTER	1804			OBEH.	3:29
15	61200	BORR, KORT, Nr. 120	1897	235/1	STÅL	HSS	18:23
16	61210	BORR, KORT, VÄNSTER, Nr. 120V	1897	235/1	STÅL	HSS	18:24
18	61230	POPNIORBORR, Nr. 123, ENKEL	1897		STÅL	HSS	18:26
19	61240	POPNIORBORR, Nr. 119, DUBBEL	1897		STÅL	HSS	18:26
18	5200	TF, TALLRIKSFJÄDER	2093 A, B, C			OBEH.	5:3
6	6120	MVPS, VARMHÅLLFASTA	2510L 24CrMo V-57				6:6
7	6130	VHM6M, VARMHÅLLF. MUTTER	2510NF 24CrMo5			OBEH.	6:5
11	14300	KLAMMER	3570A			OBEH.	14:5
11	14301	KLAMMER	3570A			FZB	14:5
9	12120	KULA	5401				12:6
9	12120	KULA	5401		A2		12:43
38	4233	SFÄRISK BRICKA	6319C			OBEH.	4:18
38	4234	SFÄRISK BRICKA	6319D			OBEH.	4:18
2	11003	CPK, HÄRDAD CYL. PINNE m6	6325	8734	STÅL		11:2
2	11004	CPK, HÄRDAD CYL. PINNE h6	6325	8734	STÅL		11:2
18	3232	M6MH, SKARVMUTTER 1,5 x D	6330		A2		3:48
18	3233	M6MH, SKARVMUTTER 1,5 x D	6330		A4		3:48
19	3232	M6MH, SKARVMUTTER 1,5 x D	6330		8-10	OBEH.	3:12
19	3233	M6MH, SKARVMUTTER 1,5 x D	6330		8-10	FZB	3:12
20	3234	M6MHF, 1,5 x D m. FLÄNS	6331		8-10	OBEH.	3:12
20	3235	M6MHF, 1,5 x D m. FLÄNS	6331		8-10	FZB	3:12
20	3234	M6MHF, 1,5 x D m. FLÄNS	6331		A2		3:48
20	3235	M6MHF, 1,5 x D m. FLÄNS	6331		A4		3:48
18	3236	M6MH, SKARVMUTTER 3 x D	6334		8-10	OBEH.	3:12
18	3237	M6MH, SKARVMUTTER 3 x D	6334		8-10	FZB	3:12
18	3236	M6MH, SKARVMUTTER 3 x D	6334		A2		3:48
18	3236	M6MH, SKARVMUTTER 3 x D	6334			OBEH.	3:55
2	4245	HRB, HÄRDAD BRICKA	6340			OBEH.	4:21
2	4046	HRB, HÄRDAD BRICKA	6340			FZB	4:21
18	5250	SPB, SPÄNNBRICKA	6796			OBEH.	5:4
18	5251	SPB, SPÄNNBRICKA	6796			MFZG	5:4
18	5250	SPB, SPÄNNBRICKA	6796		A2		5:42
18	5251	SPB, SPÄNNBRICKA	6796		A4		5:42
15	4160	LB-AT, LÅSBRICKA GROVT. AT.	6797A			OBEH.	4:13
15	4161	LB-AT, LÅSBRICKA GROVT. AT.	6797A			FZB	4:13
15	4160	LB-AT, LÅSBRICKA, GROVT. AT.	6797A		A2		4:49
15	4161	LB-AT, LÅSBRICKA, GROVT. AT.	6797A		A4		4:49
16	4162	LB-IT, LÅSBRICKA GROVT. IT.	6797I			OBEH.	4:13
16	4163	LB-IT, LÅSBRICKA GROVT. IT.	6797I			FZB	4:13
16	4162	LB-IT, LÅSBRICKA	6797I		A2		4:49
16	4163	LB-IT, LÅSBRICKA	6797I		A4		4:49
17	4170	LB-AZ, LÅSBRICKA FINT. AZ	6798A			OBEH.	4:6

SWEBOLT AB

TEL. 08-584 909 60 FAX. 08-583 581 82

BILD	ART.GR.	BENÄMNING	DIN	ISO	KVAL	YTBEH	SIDA
17	4171	LB-AZ, LÅSBRICKA FINT. AZ	6798A			FZB	4:6
17	4170	LB-AZ, LÅSBRICKA	6798A		A2		4:41
17	4171	LB-AZ, LÅSBRICKA	6798A		A4		4:41
17	4170	LB-AZ, LÅSBRICKA	6798A				4:121
18	4172	LB-IZ, LÅSBRICKA FINT. IZ	6798J			OBEH.	4:6
18	4173	LB-IZ, LÅSBRICKA FINT. IZ	6798J			FZB	4:6
18	4172	LB-IZ, LÅSBRICKA	6798J		A2		4:41
18	4173	LB-IZ, LÅSBRICKA	6798J		A4		4:41
18	4172	LB-IZ, LÅSBRICKA	6798J				4:121
19	4174	LB-IZV, FÖRSÄNKT LÅSBRICKA	6798V			OBEH.	4:13
19	4175	LB-IZV, FÖRSÄNKT LÅSBRICKA	6798V			FZB	4:13
19	4174	LB-IZV, FÖRSÄNKT LÅSBRICKA	6798V		A2		4:49
19	4175	LB-IZV, FÖRSÄNKT LÅSBRICKA	6798V		A4		4:49
8	5050	RS, SPÄRRYTTARE, AXEL	6799			OBEH.	5:1
8	5051	RS, SPÄRRYTTARE, AXEL	6799			FZB	5:1
8	5050	RS, SPÄRRYTTARE, AXEL	6799		A2		5:41
8	5050	RS, SPÄRRYTTARE, AXEL	6799		KOPPAR		5:60
8	5050	RS, SPÄRRYTTARE, AXEL	6799		TENN - BRONS		5:60
8	5051	RS, SPÄRRYTTARE, AXEL	6799		MAGNET. BRONS		5:60
1	12000	TK, TVÅR KIL	6885B				12:2
1	12000	TK, TVÅRKIL	6885B		A4		12:40
2	12010	RK, RUNDAD KIL, H9	6885A				12:1
2	12011	RK, RUNDAD KIL, H7	6885A				12:1
2	12009	RK, RUNDKIL	6885A		A2		12:41
2	12010	RK, RUNDKIL	6885A		A4		12:41
4	12030	SK, SKALLKIL	6887				12:3
3	12020	WK, WOODRUFFKIL	6888				12:2
14	14360	KAUSER	6899			FZB	14:8
14	14361	KAUSER	6899			FZV	14:8
14	14360	KAUSER	6899		A2		14:46
12	1290	M6SOB, 6-KANT + BRICKA	6900				1:54
12	1290	M6SOB, 6-KANT + BRICKA	6900		A4		1:80
25	2220	MC6SB, INSEX m. BRICKA	6900		A2		2:77
13	2140	6-KANT-NYCKEL m. TAPP	6911			OBEH.	2:32
13	2141	6-KANT-NYCKEL m. TAPP	6911			FZB	2:32
4	2050	MLC6SE, LÅG INSEXSKRUV	6912		8.8	OBEH.	2:19
4	2051	MLC6SE, LÅG INSEXSKRUV	6912		8.8	FZB	2:20
4	2050	MLC6SE, LÅG INSEXSKRUV	6912		A2		2:69
4	2051	MLC6SE, LÅG INSEXSKRUV	6912		A4		2:69
15	1295	HSB, STÅLBYGGNADSBULT	6914	7412	10.9	OBEH.	1:44
15	1296	HSB, STÅLBYGGNADSBULT	6914	7412	10.9	FZB	1:45
15	1297	HSB, STÅLBYGGNADSBULT	6914	7412	10.9	FZV	1:46
1	3040	M6MSB, STÅLBYGGN.MUTTER	6915	7414	10	OBEH.	3:6
1	3041	M6MSB, STÅLBYGGN.MUTTER	6915	7414	10	FZB	3:6
1	3042	M6MSB, STÅLBYGGN.MUTTER	6915	7414	10	FZV	3:6
3	4072	SBB, STÅLBYGGNADSBRICKA	6916	7416	C45	OBEH.	4:3
3	4073	SBB, STÅLBYGGNADSBRICKA	6916	7416	C45	FZB	4:3
3	4074	SBB, STÅLBYGGNADSBRICKA	6916	7416	C45	FZV	4:3
8	4118	IB, I-BALKSBRICKA, 14%	6917			OBEH.	4:11
8	4119	IB, I-BALKSBRICKA, 14%	6917			FZV	4:11
8	4123	IB, I-BALKSBRICKA, 14%	6918			OBEH.	4:11
8	4124	IB, I-BALKSBRICKA, 14%	6918			FZV	4:11
5	1170	M6SF, 6-KANT MED FLÄNS	6921		8.8	OBEH.	1:31
5	1171	M6SF, 6-KANT MED FLÄNS	6921		8.8	FZB	1:32
5	1172	M6SF, 6-KANT MED FLÄNS	6921		10.9	OBEH.	1:33
5	1173	M6SF, 6-KANT MED FLÄNS	6921		10.9	FZB	1:34
21	3241	M6MF, FLÄNSMUTTER	6923	4161	8	FZB	3:9
21	3242	M6MF, FLÄNSMUTTER	6923	4161	10	FZB	3:9
22	3296	M6MFT, TENSILOCK	~6923		8	FZB	3:9
4	3108	LM6MH, HÖG LÅSMUTTER	6924	7040	8	FZB	3:3

SWEBOLT AB

TEL. 08-584 909 60 FAX. 08-583 581 82

BILD	ART.GR.	BENÄMNING	DIN	ISO	KVAL	YTBEH	SIDA
4	3109	LM6MH, HÖG LÅSMUTTER	6924	7040	10	FZB	3:3
1	3117	HLM6M, HELMET. LÅSMUTTER	6925		8	OBEH.	3:4
1	3118	HLM6M, HELMET. LÅSMUTTER	6925		8	FZB	3:4
1	3119	HLM6M, HELMET. LÅSMUTTER	6925		8	FZV	3:4
23	3245	LM6MF, FLÄNSLÅSMUTTER	6926	7073	8	FZB	3:9
24	3248	HLM6MF, HELMET. FLÄNSLÅSMU	6927	7044	8	FZB	3:19
19	13060	RN, RÖRNIT	7339			FÖRNICK.	13:123
20	13065	RN, RÖRNIT	7340A				13:124
14	11130	PRYM, SPIRALSPÄNNSTIFT	7343	8750			11:6
14	11130	PRYM, SPIRALSPÄNNSTIFT	7343	8750	1.4310		11:45
14	11135	PRYM, SPIRALSPÄNNSTIFT, KRAFTIG	7344	8748			11:10
13	11125	FRP, FJÄDRANDE PINNE ENKEL	7346	~13337			11:5
1	4260	PBT, PASSBRICKA	7349		A2		4:44
1	4261	PBT, PASSBRICKA	7349		A4		4:44
2	4054	PB-FRP, PLANBRICKA FÖR FRP	7349			FZB	4:21
32	8200	M6SF-TT, TAPTITE, SEXKANT	7500D			FZB	8:8
32	8207	M6S-TT, TAPTITE UTAN FLÄNS	7500D			FZB	8:8
32	8200	M6SF-TT, SEXKANT, TAPTITE	7500D		A2		8:48
34	8205	MRX-TT, TAPTITE, KULLRIG	7500C			FZB	8:9
34	8205	MRX-TT, KULLRIG, TAPTITE	7500C		A2		8:47
35	8210	MFX-TT, TAPTITE, FÖRSÄNK	7500M			FZB	8:9
35	8210	MFX-TT, FÖRSÄNK, TAPTITE	7500M		A2		8:47
36	8216	MFT-TT, TAPTITE, FÖRS., STAR	~7500M			FZB	8:10
21	8060	RXB, KULLRIG, BORRSP., PH	7504N			FZB	8:6
21	8060	RXB, KULLRIG, BORRSPETS	7504N		A2		8:49
22	8061	RXB, KULLRIG, BORRSP., POZI	7504N			FZB	8:6
23	8062	RTB, KULLRIG, BORRSP., STAR	7504N			FZB	8:14
24	8070	FXB, FÖRSÄNK, PH	7504P			FZB	8:13
25	8071	FXB, FÖRSÄNK, POZI	7504P			FZB	8:13
26	8072	FTB, FÖRSÄNK, STAR	7504P			FZB	8:14
27	8075	KFXB, KULLERFÖRSÄNK, PH	7504Q			FZB	8:13
28	8076	KFXB, KULLERFÖRSÄNK, POZI	7504Q			FZB	8:13
29	8077	KFTB, KULLERFÖRSÄNK, STAR	7504Q			FZB	8:14
30	8080	HB-TEKS, SEXKANT, BORRSPETS	7504K			FZB	8:6
30	8081	HB-TEKS, SEXKANT, BORRSPETS	7504K			DURAL	8:6
30	8080	HB-TEKS, SEXKANT, BORRSPETS	7504K		A2		8:49
40	8300	M6SSG, GÄNGSKÄRANDE 6-KANT	7513A			OBEH.	8:15
40	8301	M6SSG, GÄNGSKÄRANDE 6-KANT	7513A			FZB	8:15
41	8310	MCSSG, GÄNGSKÄRANDE, KULL.	7513B			OBEH.	8:15
41	8311	MCSSG, GÄNGSKÄRANDE, KULL.	7513B			FZB	8:15
42	8320	MFSSG, GÄNGSKÄRANDE, FÖRS.	7513F			OBEH.	8:16
42	8321	MFSSG, GÄNGSKÄRANDE, FÖRS.	7513F			FZB	8:16
43	8330	MKFSSG, GÄNGSKÄRANDE	7513G			OBEH.	8:16
43	8331	MKFSSG, GÄNGSKÄRANDE	7513G			FZB	8:16
1	4080	TBR, TÄTNINGSBRICKA	7603				4:71
1	4080	TBR, TÄTNINGSBRICKA	7603				4:81
15	10080	RP, 6-KANT, METRISK GÄNGA	7604A+C 5.8			OBEH.	10:17
15	10081	RP, 6-KANT, METRISK GÄNGA	7604A		5.8	FZB	10:17
15	10083	RP, 6-KANT, METRISK GÄNGA	7604C		5.8	FZB	10:17
15	10080	RP, 6-KANT, METRISK GÄNGA	7604A				10:62
16	10085	RP, 6-KANT, RÖRGÄNGA	7604C		5.8	FZB	10:17
40	10460	RF, FÖRSLUTNING	7605			OBEH.	10:35
40	10461	RF, FÖRSLUTNING	7605			FZB	10:35
14	1320	6HS, HÅLSKRUV	7623A			OBEH.	1:55
14	1321	6HS, HÅLSKRUV, 2-VÄGS	7623C			OBEH.	1:56
6	17012	IMS, TYP A, INSATSM. m. SPÅR	~7965A			FZB	16:2
7	17014	IMSF, TYP B, INV. FÖRSÄNK	~7965B			FZB	16:2
8	17016	IM6S, TYP SK, INSATSM. m. INSEX	~7965SK			FZB	16:3
25	3250	PALM, PALMUTTER	7967	1479		OBEH.	3:16

SWEBOLT AB

TEL. 08-584 909 60 FAX. 08-583 581 82

BILD	ART.GR.	BENÄMNING	DIN	ISO	KVAL	YTBEH	SIDA
25	3251	PALM, PALMUTTER	7967	1479		FZB	3:16
25	3250	PALM, PALMUTTER	7967		A2		3:45
25	3251	PALM, PALMUTTER	7967		A4		3:45
6	1200	M6SPB, 6-KANT, PASSNING h11	7968		5.6	OBEH.	1:47
8	10046	MFSS, FÖRSÄNKT, MEJSELSPÅR	7969		4.6	OBEH.	10:14
8	10047	MFSS, FÖRSÄNKT, MEJSELSPÅR	7969		4.6	FZB	10:14
1	8001	CSS, CYL. SKALLE, SPETS	7971C	1481C		FZB	8:4
1	8000	CSS, CYL. SKALLE, SPETS	7971C	1481C	A2		8:41
1	8001	CSS, CYL. SKALLE, SPETS	7971C	1481C	A4		8:42
1	8000	CSS, CYL SKALLE, SPETS	7971C	1481			8:70
2	8004	CSK, CYL. SKALLE, TRUBBIG	7971F	1481F		FZB	8:2
3	8006	FSS, FÖRSÄNKT, SPETS	7972C	1482C		FZB	8:4
3	8005	FSS, FÖRSÄNKT, SPETS	7972C	1482C	A2		8:41
3	8006	FSS, FÖRSÄNKT, SPETS	7972C	1482C	A4		8:42
4	8007	FSK, FÖRSÄNKT, TRUBBIG	7972F	1482F		FZB	8:1
5	8010	KFSS, KULLERFÖRSÄNKT	7973C	1483C		FZB	8:4
5	8009	KFSS, KULLERFÖRSÄNKT	7973C	1483C	A2		8:41
5	8010	KFSS, KULLERFÖRSÄNKT	7973C	1483C	A4		8:42
18	8050	BSS, 6-KANT, SPETSIG	7976C	1479C		FZB	8:5
18	8050	BSS, 6-KANT, SPETSIG	7976C	1479C	A2		8:49
19	8051	BSK, 6-KANT, TRUBBIG	7976F	1479F		FZB	8:5
6	11055	GKP, GÅNG KONISK PINNE	7977	8737			11:7
5	11030	IGKP, KONISK, INV. GÅNGA h10	7978	8736			11:14
11	4143	FBR, FJÄDERBRICKA f. INSEX	7980			OBEH.	4:10
11	4144	FBR, FJÄDERBRICKA f. INSEX	7980			FZB	4:10
11	4143	FBR, FJÄDERBRICKA	7980		A2		4:43
11	4144	FBR, FJÄDERBRICKA	7980		A4		4:43
6	8011	RXS, KULLRIG, SPETS, PH	7981C	7049C		FZB	8:1
6	8011	RXS, KULLRIG, SPETS, PH	7981C	7049C	A2		8:43
6	8013	RXS, KULLRIG, SPETS, PH	7981C	7049C	A4		8:44
7	8012	RXS, KULLRIG, SPETS, POZI	7981C	7049C		FZB	8:1
7	8012	RXS, KULLRIG, SPETS, POZI	7981C	7049C	A2		8:43
7	8014	RXS, KULLRIG, SPETS, POZI	7981C	7049C	A4		8:44
8	8015	RTS, KULLRIG, SPETS, STAR	7981C	7049C		FZB	8:3
8	8015	RTS, KULLRIG, SPETS, STAR	7981C	7049C	A2		8:45
8	8016	RTS, KULLRIG, SPETS, STAR	7981C	7049C	A4		8:46
9	8020	RXK, KULLRIG, TRUBBIG, PH	7981F	7049F		FZB	8:2
10	8021	RXK, KULLRIG, TRUBBIG, POZI	7981F	7049F		FZB	8:2
11	8023	RTK, TRUBBIG, STAR	7981F	7049F		FZB	8:3
39	8220	RXSF, KULLRIG MED FLÄNS	~7981			FZB	8:7
12	8030	FXS, FÖRSÄNKT, SPETS, PH	7982C	7050C		FZB	8:1
12	8030	FXS, FÖRSÄNKT, SPETS, PH	7982C	7050C	A2		8:43
12	8032	FXS, FÖRSÄNKT, SPETS, PH	7982C	7050C	A4		8:44
13	8031	FXS, FÖRSÄNKT, SPETS, POZI	7982C	7050C		FZB	8:1
13	8031	FXS, FÖRSÄNKT, SPETS, POZI	7982C	7050C	A2		8:43
13	8033	FXS, FÖRSÄNKT, SPETS, POZI	7982C	7050C	A4		8:44
14	8035	FTS, FÖRSÄNKT, SPETS, STAR	7982C	7050C		FZB	8:3
14	8034	FTS, FÖRSÄNKT, SPETS, STAR	7982C	7050C	A2		8:45
14	8035	FTS, FÖRSÄNKT, SPETS, STAR	7982C	7050C	A4		8:46
15	8040	KFXS, KULLERFÖRSÄNKT, PH	7983C	7051C		FZB	8:1
15	8040	KFXS, KULLERFÖRSÄNKT, PH	7983C	7051C	A2		8:43
15	8042	KFXS, KULLERFÖRSÄNKT, PH	7983C	7051C	A4		8:44
16	8041	KFXS, KULLERFÖRSÄNKT, POZI	7983C	7051C		FZB	8:1
16	8041	KFXS, KULLERFÖRSÄNKT, POZI	7983C	7051C	A2		8:43
16	8043	KFXS, KULLERFÖRSÄNKT, POZI	7983C	7051C	A4		8:44
17	8049	KFTS, KULLERFÖRSÄNKT, STAR	7983C	7051C		FZB	8:3
17	8048	KFTS, KULLERFÖRSÄNKT, STAR	7983C	7051C	A2		8:45
17	8049	KFTS, KULLERFÖRSÄNKT, STAR	7983C	7051C	A4		8:46
5	2060	MLC6S, LÅG INSEXSKRUV	7984		8.8	OBEH.	2:17
5	2061	MLC6S, LÅG INSEXSKRUV	7984		8.8	FZB	2:18

SWEBOLT AB

TEL. 08-584 909 60 FAX. 08-583 581 82

BILD	ART.GR.	BENÄMNING	DIN	ISO	KVAL	YTBEH	SIDA
5	2062	MLC6S, LÅG INSEXSKRUV	7984		10.9	OBEH.	2:21
5	2060	MLC6S, LÅG INSEXSKRUV	7984		A2		2:70
5	2061	MLC6S, LÅG INSEXSKRUV	7984		A4		2:70
22	2210	MLCTS, LÅG INV STAR SKRUV	~7984		8.8	OBEH.	2:39
22	2211	MLCTS, LÅG INV STAR SKRUV	~7984		8.8	FZB	2:39
6	7050	MRX, CYL. KULLERSKALLE, PH	7985	7045	4.8	OBEH.	7:9
6	7051	MRX, CYL. KULLERSKALLE, PH	7985	7045	4.8	FZB	7:9
6	7053	MRX, LITEN CYL. KULLERSK. PH	~7985	~7045	4.8	FZB	7:11
6	7050	MRX, CYL. KULLERSKALLE, PH	7985	7045	A2		7:44
6	7051	MRX, CYL. KULLERSKALLE, PH	7985	7045	A4		7:44
7	7061	MRX, CYL. KULLERSK., POZI	7985	7045	4.8	FZB	7:9
7	7060	MRX, CYL. KULLERSKALLE, POZI	7985	7045	A2		7:44
7	7061	MRX, CYL. KULLERSKALLE, POZI	7985	7045	A4		7:44
28	7052	MRT, CYL. KULLERSK., STAR	~7985	~7045	4.8	OBEH.	7:12
28	7052	MRT, CYL. KULLERSKALLE, STAR	~7985	~7045	A2		7:47
28	7053	MRT, CYL. KULLERSKALLE, STAR	~7985	~7045	A4		7:47
28	7053	MRT, CYL. KULLERSK., STAR	~7985	~7045	4.8	FZB	7:12
28	7055	MRT, CYL. KULLERSK., STAR	~7985	~7045	8.8	FZB	7:12
15	7160	MRX Z4, OFÖRLORBAR LÅSBR.	7985 Z4/6905		4.8	FZB	7:16
14	7150	MRX Z1, OFÖRLORBAR BR.	7985 Z1/6902A		4.8	FZB	7:16
34	4076	SBRB, STÅLBYGGNADSBRICKA	7989			OBEH.	4:3
34	4077	SBRB, STÅLBYGGNADSBRICKA	7989			FZB	4:3
34	4078	SBRB, STÅLBYGGNADSBRICKA	7989			FZV	4:3
8	1193	SBL, STÅLLBYGGNANDBULT	7990		4.6-5.6	OBEH.	1:48
8	1194	SBL, STÅLLBYGGNADSBULT	7990		4.6-5.6	FZB	1:49
8	1195	SBL, STÅLLBYGGNADSBULT	7990		4.6-5.6	FZV	1:50
3	2030	MF6S, FÖRSÄNKT INSEXSKRUV	7991		8.8	OBEH.	2:15
3	2031	MF6S, FÖRSÄNKT INSEXSKRUV	7991		10.9	OBEH.	2:13
3	2032	MF6S, FÖRSÄNKT INSEXSKRUV	7991		10.9	FZB	2:14
3	2033	MF6S, FÖRSÄNKT INSEXSKRUV	7991		8.8	FZB	2:16
3	2030	MF6S, FÖRSÄNKT INSEXSKRUV	7991		A2		2:67
3	2031	MF6S, FÖRSÄNKT INSEXSKRUV	7991		A4		2:68
23	2215	MFTS, FÖRS. INSEXS. m. STAR	~7991		8.8	OBEH.	2:40
23	2216	MFTS, FÖRS. INSEXS. m. STAR	~7991		8.8	FZB	2:40
12	5070	SB, LÅSRING, AXEL RUND	7993A			OBEH.	5:9
12	5071	SB, LÅSRING, AXEL RUND	7993A			MFZG	5:9
13	5080	RW, KLÄMLÅSRING, HÅL	7993B			OBEH.	5:9
13	5081	RW, KLÄMLÅSRING, HÅL	7993B			MFZG	5:9
8	9036	TKFX, KULLERFÖRSÄNKT, POZI	7995			FZB	9:9
8	9035	TKFX, KULLERFÖRSÄNKT, POZI	7995		A2		9:55
8	9036	TKFX, KULLERFÖRSÄNKT, POZI	7995		A4		9:56
8	9035	TKFX, KULLERFÖRSÄNKT, POZI	7995				9:61
8	9036	TKFX, KULLERFÖRSÄNKT, POZI	7995			FÖRNICKLAD	9:61
6	9026	TRX, KULLRIG, POZI	7996			FZB	9:9
6	9025	TRX, KULLRIG, POZI	7996		A2		9:55
6	9026	TRX, KULLRIG, POZI	7996		A4		9:56
6	9025	TRX, KULLRIG, POZI	7996				9:61
6	9026	TRX, KULLRIG, POZI	7996			FÖRNICKLAD	9:61
7	9031	TFX, FÖRSÄNKT, POZI	7997			FZB	9:9
7	9030	TFX, FÖRSÄNKT, POZI	7997		A2		9:55
7	9031	TFX, FÖRSÄNKT, POZI	7997		A4		9:56
7	9030	TFX, FÖRSÄNKT, POZI	7997				9:61
7	9031	TFX, FÖRSÄNKT, POZI	7997			FÖRNICKLAD	9:61
2	4070	RBS, STOR PLANBRICKA	9021	7093		OBEH.	4:3
2	4071	RBS, STOR PLANBRICKA	9021	7093		FZB	4:3
2	4069	RBS, STOR PLANBRICKA	9021	7093		FZV	4:3
2	4070	RBS, STOR PLANBRICKA	9021		A2		4:40
2	4071	RBS, STOR PLANBRICKA	9021		A4		4:40
2	4070	RBS, STOR PLANBRICKA	9021	7093			4:60
2	4071	RBS, STOR PLANBRICKA	9021	7093		FÖRNICKLAD	4:60

SWEBOLT AB

TEL. 08-584 909 60 FAX. 08-583 581 82

BILD	ART.GR.	BENÄMNING	DIN	ISO	KVAL	YTBEH	SIDA
2	4070	RBS, STOR PLANBRICKA	9021	7093			4:90
2	4070	RBS, STOR PLANBRICKA	9021	7093			4:70
2	4070	RBS, STOR PLANBRICKA	9021	7093			4:80
2	14010	LN, LÅSNÅL	11024			FZB	14:2
2	14010	LN, LÅSNÅL	11024		A4		14:43
3	14020	DLN, DUBBEL LÅSNÅL	11024			FZB	14:2
20	17060	IGA, INSATSG. f. PLAST, TYP A	16903A				16:8
21	17062	IGC, INSATSG. f. PLAST, TYP C	16903C				16:8
22	17064	IGB, INSATSG. f. PLAST, TYP B	16903B				16:9
23	17066	IGD, INSATSG. f. PLAST, TYP D	16903D				16:9
25	17070	IGG, INSATSG. f. PLAST, TYP G	16903G				16:10
26	17072	IGF, INSATSG. f. PLAST, TYP F	16903F				16:11
27	17074	IGH, INSATSG. f. PLAST, TYP H	16903H				16:11
28	17076	IGP, INSATSG. f. PLAST, TYP P	16903P				16:12
29	17078	IGR, INSATSG. f. PLAST, TYP R	16903R				16:12
30	17080	IGQ, INSATSG. f. PLAST, TYP Q	16903Q				16:13
31	17082	IGS, INSATSG. f. PLAST, TYP S	16903S				16:13
5	10035	FÖRSÄNKTK m. TVÅ KNASTER	25195			OBEH.	10:13
5	10036	FÖRSÄNKTK m. TVÅ KNASTER	25195			FZB	10:13
30	4235	ABA, ANSLUTNINGBRICKA	46288A			OBEH.	4:9
30	4236	ABA, ANSLUTNINGBRICKA	46288A			FZB	4:9
31	4240	ABB, ANSLUTNINGBRICKA	46288B			OBEH.	4:9
31	4241	ABB, ANSLUTNINGBRICKA	46288B			FZB	4:9
26	4210	LBFL, FLERLÄPPS LÅSBLECK	70952A			OBEH.	4:15
26	4211	LBFL, FLERLÄPPS LÅSBLECK	70952A			FZB	4:15
38	10430	GAFFELLÄNK	71752			OBEH.	10:34
22	14440	KOMP. KULLED	71802A				14:12
23	14441	KOMP. KULLED MED GÄNGA	71802CS				14:12
24	14442	KOMP. KULLED FÖR NITNING	71802BS				14:12
20	14350	KULTAPP MED GÄNGA	71803C				14:11
21	14351	KULTAPP UTAN GÄNGA FÖR NITNING	71803B				14:11
17	14420	KULLED SHÄLLARE	71805A				14:11
18	14421	KULLED SHÄLLARE	71805B				14:11
29	4230	FR, FJÄDERRING KONISK	74361C			OBEH.	4:9
29	4231	FR, FJÄDERRING KONISK	74361C			FZB	4:9
48	3701	HM, HJULMUTTER	74361A		8	FZB	3:22
49	3706	HMF, HJULMUTTER m. FLÄNS	74361B		8	FZB	3:22
49	3708	HMF, HJULMUTTER m. FLÄNS	74361B		10	FZB	3:22

SWEBOLT AB

TEL. 08-584 909 60 FAX. 08-583 581 82

ISO - ORDNING

13	61000	BORR, CYLINDRISK, Nr. 100	338	235/1	STÅL	HSS	18:20
15	61200	BORR, KORT, Nr. 120	1897	235/1	STÅL	HSS	18:23
16	61210	BORR, KORT, VÄNSTER, Nr. 120V	1897	235/1	STÅL	HSS	18:24
14	61300	BORR, KONISK, Nr. 130	345	235/1	STÅL	HSS	18:22
20	62100	DUBBHÅLSBORR, Nr. 210	333R	2541	STÅL	HSS	18:27
29	61040	GÄNGTAPP, M, GROVGÄNGA		529	STÅL	HSS	18:33
29	61042	GÄNGTAPP, M, FING.	UNC	529	STÅL	HSS	18:34
29	61043	GÄNGTAPP, M, FING., BOTTENH.	UNF	529	STÅL	HSS	18:34
29	61070	GÄNGTAPP, VÄNSTER, Nr. 1040V		529	STÅL	HSS	18:35
29	61071	GÄNGTAPP, VÄNSTER, Nr. 1040V	UNC	529	STÅL	HSS	18:36
29	61072	GÄNGTAPP, VÄNSTER, Nr. 1040V	UNF	529	STÅL	HSS	18:36
1	7000	MCS, CYL. SKALLE	84	1207	4.8	OBEH.	7:1
1	7000	MCS, CYL. SKALLE	84	1207	A2		7:41
1	7000	MCS, CYL. SKALLE	84	1207			7:60
1	7000	MCS, CYL. SKALLE	84	1207			7:80
1	7000	MCS, CYL. SKALLE	84	1207			7:70
1	7001	MCS, CYL. SKALLE	84	1207	4.8	FZB	7:1
1	7001	MCS, CYL. SKALLE	84	1207	A4		7:41
1	7001	MCS, CYL. SKALLE	84	1207		FÖRNICKLAD	7:60
1	7003	MCS, CYL. SKALLE	84	1207	8.8	FZB	7:2
1	14000	SP, SAXPINNE	94	1234		OBEH.	14:1
1	14000	SP, SAXPINNE	94	1234	A2		14:41
1	14001	SP, SAXPINNE	94	1234		FZB	14:1
1	14001	SP, SAXPINNE	94	1234	A4		14:42
25	3250	PALM, PALMUTTER	7967	1479		OBEH.	3:16
25	3251	PALM, PALMUTTER	7967	1479		FZB	3:16
18	8050	BSS, 6-KANT, SPETSIG	7976C	1479C		FZB	8:5
18	8050	BSS, 6-KANT, SPETSIG	7976C	1479C	A2		8:49
19	8051	BSK, 6-KANT, TRUBBIG	7976F	1479F		FZB	8:5
1	8000	CSS, CYL SKALLE, SPETS	7971C	1481			8:70
1	8000	CSS, CYL. SKALLE, SPETS	7971C	1481C	A2		8:41
1	8001	CSS, CYL. SKALLE, SPETS	7971C	1481C		FZB	8:4
1	8001	CSS, CYL. SKALLE, SPETS	7971C	1481C	A4		8:42
2	8004	CSK, CYL. SKALLE, TRUBBIG	7971F	1481F		FZB	8:2
3	8005	FSS, FÖRSÄNKT, SPETS	7972C	1482C	A2		8:41
3	8006	FSS, FÖRSÄNKT, SPETS	7972C	1482C		FZB	8:4
3	8006	FSS, FÖRSÄNKT, SPETS	7972C	1482C	A4		8:42
4	8007	FSK, FÖRSÄNKT, TRUBBIG	7972F	1482F		FZB	8:1
5	8009	KFSS, KULLERFÖRSÄNKT	7973C	1483C	A2		8:41
5	8010	KFSS, KULLERFÖRSÄNKT	7973C	1483C		FZB	8:4
5	8010	KFSS, KULLERFÖRSÄNKT	7973C	1483C	A4		8:42
4	7030	MSCS, STOR CYL. SKALLE	85	1580	A2		7:51
4	7030	MSCS, STOR CYL. SKALLE	85	1580			7:63
4	7030	MSCS, STOR CYL. SKALLE	85	1580			7:81
4	7031	MSCS, STOR CYL SKALLE	85	1580	4.8	FZB	7:7
4	7031	MSCS, STOR CYL. SKALLE	85	1580	A4		7:52
4	7031	MSCS, STOR CYL. SKALLE	85	1580		FÖRNICKLAD	7:63
4	7033	MSCS, STOR CYL SKALLE	85	1580	8.8	FZB	7:8
2	7010	MFS, FÖRSÄNKT	963	2009	4.8	OBEH.	7:3
2	7010	MFS, FÖRSÄNKT	963	2009	A2		7:42
2	7010	MFS, FÖRSÄNKT	963	2009			7:61
2	7010	MFS, FÖRSÄNKT	963	2009			7:80
2	7010	MFS, FÖRSÄNKT	963	2009			7:71
2	7011	MFS, FÖRSÄNKT	963	2009	4.8	FZB	7:3
2	7011	MFS, FÖRSÄNKT	963	2009	A4		7:42
2	7011	MFS, FÖRSÄNKT	963	2009		FÖRNICKLAD	7:61
2	7013	MFS, FÖRSÄNKT	963	2009	8.8	FZB	7:4

SWEBOLT AB

TEL. 08-584 909 60 FAX. 08-583 581 82

BILD	ART.GR.	BENÄMNING	DIN	ISO	KVAL	YTBEH	SIDA
3	7020	MKFS, KULLERFÖRSÄNK	964	2010	A2		7:43
3	7020	MKFS, KULLERFÖRSÄNK	964	2010			7:62
3	7020	MKFS, KULLERFÖRSÄNK	964	2010			7:81
3	7020	MKFS, KULLERFÖRSÄNK	964	2010			7:71
3	7021	MKFS, KULLERFÖRSÄNK	964	2010	4.8	FZB	7:5
3	7021	MKFS, KULLERFÖRSÄNK	964	2010	A4		7:43
3	7021	MKFS, KULLERFÖRSÄNK	964	2010		FÖRNICKLAD	7:62
1	11000	CP, CYL. PINNE	h8 7	2338	STÅL		11:1
1	11001	CP, CYL. PINNE	m6 7	2338	STÅL		11:1
1	11001	CP, CYL. PINNE	m6 7	2338	A2		11:42
1	11002	CP, CYL. PINNE	h6 7	2338	STÅL		11:3
1	11002	CP, CYL. PINNE	h8 7	2338	A1		11:42
1	11003	CP, CYL. PINNE	m6 7	2338	A4		11:43
1	11004	CP, CYL. PINNE	h8 7	2338	A4		11:43
4	11020	KP, KONISK PINNE	1	2339	STÅL		11:4
4	11020	KP, KONISK PINNE	1	2339	A2		11:44
4	11021	KP, KONISK PINNE	1	2339	STÅL	HÄRDAD	11:5
4	11021	KP, KONISK PINNE	1	2339	A4		11:44
21	7220	LP, LÅSPINNE m. SPÅR	427	2342		OBEH.	7:17
21	7221	LP, LÅSPINNE m. SPÅR	427	2342		FZB	7:17
12	2130	6KN, 6-KANT-NYCKEL	911	2936		OBEH.	2:31
12	2131	6KN, 6-KANT-NYCKEL	911	2936		FZB	2:31
12	2136	6KN, 6-KANT-NYCKEL m. INV HÅL för SÄKERHETSSKRUV	~911	2936		STÅL	2:32
17	10100	LT, LYFTÖGLA, TAPP	580	3266	C15	OBEH.	10:4
17	10101	LT, LYFTÖGLA, TAPP	580	3266	C15	FZB	10:4
17	10102	LT, LYFTÖGLA, TAPP	580	3266	C15	FZV	10:4
17	10105	LT, LYFTÖGLA, TAPP, UNC	580	3266	C15	OBEH.	10:26
17	10106	LT, LYFTÖGLA, TAPP, UNC	580	3266	C15	FZB	10:26
17	10107	LT, LYFTÖGLA, TAPP, UNC	580	3266	C15	FZV	10:26
4	1110	M6S, 6-KANT, DELG.		4014	8.8	OBEH.	1:3-4
4	1110	M6S, ROSTFRI, DELG.		4014	A2		1:72
4	1110	M6S, 6-KANT, DELG.	931	4014			1:81
4	1110	M6S, 6-KANT, DELG.	931	4014			1:87
4	1111	M6S, 6-KANT, DELG.		4014	8.8	FZB	1:7-8
4	1111	M6S, SYRAFAST, DELG.		4014	A4		1:76
4	1111	M6S, 6-KANT, DELG.	931	4014		FÖRNICKLAD	1:82
4	1112	M6S, 6-KANT, DELG.		4014	8.8	FZV	1:10
4	1112	M6S, SYRAFAST, DELG.		4014	A4-80		1:74
4	1130	M6S, 6-KANT, DELG.		4014	10.9	OBEH.	1:13-14
4	1131	M6S, 6-KANT, DELG.		4014	10.9	FZB	1:17-18
4	1131	M6S, ROSTFRI, DELG.	931	4014	A2	FZB	1:84
4	1133	M6S, SYRAFAST, DELG.	931	4014	A4-80	FZB	1:86
4	1137	M6S, 6-KANT, DELG.		4014	12.9	OBEH.	1:20
2	1106	M6S, 6-KANT, DELG.	601	4016	4.6-6.8	FZB	1:41
2	1105	M6S, 6-KANT, HELG.	601	4016	4.6-6.8	OBEH.	1:40
3	1110	M6SH, 6-KANT, HELG.		4017	8.8	OBEH.	1:1-2
3	1110	M6SH, ROSTFRI, HELG.		4017	A2		1:71
3	1110	M6SH, 6-KANT, HELG.	933	4017			1:81
3	1110	M6SH, 6-KANT, HELG.	933	4017			1:87
3	1110	M6SH, 6-KANT, HELG.	933	4017			1:85
3	1110	M6SH, 6-KANT, HELG.	933	4017			1:86
3	1110	M6SH, 6-KANT, HELG.	933	4017			1:88
3	1111	M6SH, 6-KANT, HELG.		4017	8.8	FZB	1:5-6
3	1111	M6SH, SYRAFAST, HELG.		4017	A4		1:75
3	1111	M6SH, 6-KANT, HELG.	933	4017		FÖRNICKLAD	1:82
3	1112	M6SH, 6-KANT, HELG.		4017	8.8	FZV	1:9
3	1112	M6SH, SYRAFAST, HELG.		4017	A4-80		1:73
3	1120	UDDA LÄNGDER HELG.		4017	8.8	OBEH.	1:1-2
3	1120	UDDA LÄNGDER HELG.		4017	A2		1:71

SWEBOLT AB

TEL. 08-584 909 60 FAX. 08-583 581 82

BILD	ART.GR.	BENÄMNING	DIN	ISO	KVAL	YTBEH	SIDA
3	1121	UDDA LÄNGDER HELG.		4017	8.8	FZB	1:5-6
3	1121	UDDA LÄNGDER HELG.		4017	A4		1:75
3	1122	UDDA LÄNGDER HELG.		4017	8.8	FZV	1:9
3	1122	UDDA LÄNGDER HELG.		4017	A4-80		1:73
3	1130	M6SH,6-KANT, HELG.		4017	10.9	OBEH.	1:11-12
3	1130	M6SH, ROSTFRI, HELG.	933	4017	A2	FZB	1:83
3	1131	M6SH,6-KANT, HELG.		4017	10.9	FZB	1:15-16
4	1132	UDDA LÄNGDER, HELG.		4017	10.9	OBEH.	1:11-12
3	1132	M6SH, SYRAFAST, HELG.	933	4017	A4-80	FZB	1:85
4	1133	UDDA LÄNGDER, HELG.		4017	10.9	FZB	1:15-16
3	1136	M6SH, 6-KANT, HELG.		4017	12.9	OBEH.	1:19
21	2050	STOPPSKRUV ESLOK, PLAN	913	4026		OBEH.	2:53
8	2080	P6SS, STOPPSKRUV PLAN	913	4026	45HRC	OBEH.	2:27
8	2080	P6SS, STOPPSKRUV PLAN	913	4026	A2		2:73
8	2081	P6SS, STOPPSKRUV PLAN	913	4026	45HRC	FZB	2:29
8	2081	P6SS, STOPPSKRUV PLAN	913	4026	A4		2:74
21	2052	STOPPSKRUV ESLOK, SPETS	914	4027		OBEH.	2:53
9	2090	S6SS, STOPPSKRUV m. SPETS	914	4027	45HRC	OBEH.	2:27
9	2090	S6SS, STOPPSKRUV m. SPETS	914	4027	A2		2:73
9	2091	S6SS, STOPPSKRUV m. SPETS	914	4027	45HRC	FZB	2:29
9	2091	S6SS, STOPPSKRUV m. SPETS	914	4027	A4		2:74
21	2054	STOPPSKRUV ESLOK, TAPP	915	4028		OBEH.	2:53
10	2100	T6SS, STOPPSKRUV m. TAPP	915	4028	45HRC	OBEH.	2:28
10	2100	T6SS, STOPPSKRUV m. TAPP	915	4028	A2		2:73
10	2101	T6SS, STOPPSKRUV m. TAPP	915	4028	45HRC	FZB	2:30
10	2101	T6SS, STOPPSKRUV m. TAPP	915	4028	A4		2:74
21	2056	STOPPSKRUV ESLOK, SKÅL	916	4029		OBEH.	2:53
11	2110	SK6SS, STOPPSKRUV SKÅLAD	916	4029	45HRC	OBEH.	2:28
11	2110	SK6SS, STOPPSKRUV SKÅLAD	916	4029	A2		2:73
11	2111	SK6SS, STOPPSKRUV SKÅLAD	916	4029	45HRC	FZB	2:30
11	2111	SK6SS, STOPPSKRUV SKÅLAD	916	4029	A4		2:74
1	3012	M6M, SEXKANTMUTTER		4032	A2		3:43
1	3013	M6M, SEXKANTMUTTER 0,9d	970	4032	8	OBEH.	3:1
1	3013	M6M, SEXKANTMUTTER		4032	A4-80		3:43
1	3014	M6M, SEXKANTMUTTER 0,9d	970	4032	8	FZB	3:1
1	3015	M6M, SEXKANTMUTTER 0,9d	970	4032	8	FZV	3:1
1	3016	M6M, SEXKANTMUTTER	934	4032	A2	FZB	3:43
1	3017	M6M, SEXKANTMUTTER	934	4032	A4-80	FZB	3:43
1	3018	M6M, SEXKANTMUTTER 0,9d	970	4032	10	OBEH.	3:2
1	3019	M6M, SEXKANTMUTTER 0,9d	970	4032	10	FZB	3:2
1	3021	M6M, SEXKANTMUTTER 0,9d	970	4032	12	OBEH.	3:2
1	3024	VM6M, VÄNSTERGÄNGA 0,9d	970	4032	8	OBEH.	3:18
1	3025	VM6M, VÄNSTERGÄNGA 0,9d	970	4032	8	FZB	3:18
1	3032	FM6M, FINGÄNGA	970	4032	8	OBEH.	3:7
1	3033	FM6M, FINGÄNGA	970	4032	8	FZB	3:7
1	3036	FM6M, FINGÄNGA	970	4032	10	OBEH.	3:7
1	3039	VFM6M, FING., VÄNSTERG.	970	4032	8	OBEH.	3:18
1	3043	M6M, SEXKANTMUTTER 1,0d		4033	8	OBEH.	3:17
1	3043	M6M, SEXKANTMUTTER 1,0d		4033		OBEH.	3:53
1	3044	M6M, SEXKANTMUTTER 1,0d		4033	8	FZB	3:17
1	3044	M6M, SEXKANTMUTTER 1,0d		4033		FÖRNICKLAD	3:53
1	3045	M6M, SEXKANTMUTTER 1,0d		4033	10	OBEH.	3:17
1	3046	M6M, SEXKANTMUTTER 1,0d		4033	10	FZB	3:17
1	3047	M6M, SEXKANTMUTTER 1,0d		4033	12	OBEH.	3:17
1	3058	RM6M, RÖRGÄNGA	~934	~4033	6	OBEH.	3:32
1	3001	M6M, SEXKANTMUTTER	555	4034	6	OBEH.	3:17
1	3001	M6M, SEXKANTMUTTER	555	4034			3:90
1	3002	M6M, SEXKANTMUTTER	555	4034	6	FZB	3:17
1	3003	M6M, SEXKANTMUTTER	555	4034	6	FZV	3:17
2	3070	VML6M, LÄG, VÄNSTERG.	936/439B	4035	6	OBEH.	3:5

SWEBOLT AB

TEL. 08-584 909 60 FAX. 08-583 581 82

BILD	ART.GR.	BENÄMNING	DIN	ISO	KVAL	YTBEH	SIDA
2	3071	VML6M, LÅG, VÄNSTERG.	936/439B	4035	6	FZB	3:5
2	3075	FML6M, FINGÄNGA	936/439B	4035	6	OBEH.	3:8
2	3076	FML6M, FINGÄNGA	936/439B	4035	6	FZB	3:8
2	3085	ML6M, LÅG SEXKANTMUTTER	439B	4035	6	OBEH.	3:5
2	3085	ML6M, LÅGMUTTER	439	4035	A2		3:40
2	3085	ML6M, LÅG SEXKANTMUTTER	439B	4035		OBEH.	3:52
2	3086	ML6M, LÅG SEXKANTMUTTER	439B	4035	6	FZB	3:5
2	3086	FML6M, LÅGMUTTER, FING.	439	4035	A4		3:40
2	3086	ML6M, LÅG SEXKANTMUTTER	439B	4035		FÖRNICKLAD	3:52
2	3087	ML6M, LÅG SEXKANTMUTTER	439B	4035	6	FZV	3:5
21	3241	M6MF, FLÄNSMUTTER	6923	4161	8	FZB	3:9
21	3242	M6MF, FLÄNSMUTTER	6923	4161	10	FZB	3:9
1-2	2000	MC6S, INSEXSKRUV	912	4762	8.8	OBEH.	2:1-2
1-2	2000	MC6S, INSEXSKRUV	912	4762	A2		2:61
1-2	2000	MC6S, INSEXSKRUV	912	4762			2:84
1-2	2001	MC6S, INSEXSKRUV	912	4762	8.8	FZB	2:3-4
1-2	2001	MC6S, INSEXSKRUV	912	4762	A4		2:64
1-2	2002	MC6S, INSEXSKRUV	912	4762	8.8	DACROMET	2:7
2	2003	MC6SH, INSEXSKRUV, HELG	912	4762	8.8	OBEH.	2:8
2	2003	MC6SH, HELGÄNGA	912	4762	A2		2:63
2	2004	MC6SH, INSEXSKRUV, HELG.	912	4762	8.8	FZB	2:8
2	2004	MC6SH, HELGÄNGA	912	4762	A4		2:63
1-2	2005	MC6S, INSEXSKRUV	912	4762	12.9	OBEH.	2:5-6
1-2	2005	MC6S, INSEXSKRUV	912	4762	A4-80		2:62
2	2006	MC6SH, INSEXSKRUV, HELG.	912	4762	12.9	OBEH.	2:12
1-2	2007	MC6S, INSEXSKRUV	912	4762	10.9	OBEH.	2:10
1-2	2008	MC6S, INSEXSKRUV	912	4762	10.9	FZB	2:11
1-2	2009	MC6S, INSEXSKRUV	912	4762	10.9	DACROMET	2:11
1-2	2013	FMC6S, INSEXSKRUV, FING.	912	4762	8.8	OBEH.	2:9
1-2	2014	FMC6S, INSEXSKRUV, FING.	912	4762	8.8	FZB	2:9
1-2	2014	MC6S, INSEXSKRUV	912	4762	A2	FÖRZINKAD	2:65
1-2	2015	FMC6S, INSEXSKRUV, FING.	912	4762	12.9	OBEH.	2:12
1-2	2015	MC6S, INSEXSKRUV	912	4762	A4-80	FÖRZINKAD	2:66
16	7170	PSS, PLAN m. SPÅR	551	4766		OBEH.	7:14
16	7170	PSS, PLAN m. SPÅR	551	4766	A1		7:54
16	7170	PSS, PLAN m. SPÅR	551	4766			7:65
16	7170	PSS, PLAN m. SPÅR	551	4766			7:81
16	7171	PSS, PLAN m. SPÅR	551	4766		FZB	7:14
16	7171	PSS, PLAN m. SPÅR	551	4766	A4		7:54
4	3108	LM6MH, HÖG LÅSMUTTER	6924	7040	8	FZB	3:3
4	3109	LM6MH, HÖG LÅSMUTTER	6924	7040	10	FZB	3:3
5	3120	HLM6M, HELMET. LÅSMUTTER	980	7042	8	OBEH.	3:4
5	3121	HLM6M, HELMET. LÅSMUTTER	980	7042	8	FZB	3:4
5	3122	HLM6M, HELMET. LÅSMUTTER	980	7042	8	FZV	3:4
5	3126	HLM6M, HELMET. LÅSMUTTER	980	7042	10	FZB	3:4
5	3127	FHLM6M, HELMET. FINGÄNGA	980	7042	10	FZB	3:4
24	3248	HLM6MF, HELMET. FLÄNSLÅSMU	6927	7044	8	FZB	3:19
6	7050	MRX, CYL. KULLERSKALLE, PH	7985	7045	4.8	OBEH.	7:9
6	7050	MRX, CYL. KULLERSKALLE, PH	7985	7045	A2		7:44
6	7051	MRX, CYL. KULLERSKALLE, PH	7985	7045	4.8	FZB	7:9
6	7051	MRX, CYL. KULLERSKALLE, PH	7985	7045	A4		7:44
28	7052	MRT, CYL. KULLERSK., STAR	~7985	~7045	4.8	OBEH.	7:12
28	7052	MRT, CYL. KULLERSKALLE, STAR~7985	~7985	~7045	A2		7:47
28	7053	MRT, CYL. KULLERSKALLE, STAR~7985	~7985	~7045	A4		7:47
6	7053	MRX, LITEN CYL. KULLERSK. PH	~7985	~7045	4.8	FZB	7:11
28	7053	MRT, CYL. KULLERSK., STAR	~7985	~7045	4.8	FZB	7:12
28	7055	MRT, CYL. KULLERSK., STAR	~7985	~7045	8.8	FZB	7:12
7	7060	MRX, CYL. KULLERSKALLE, POZI	7985	7045	A2		7:44
7	7061	MRX, CYL. KULLERSK., POZI	7985	7045	4.8	FZB	7:9
7	7061	MRX, CYL. KULLERSKALLE, POZI	7985	7045	A4		7:44

SWEBOLT AB

TEL. 08-584 909 60 FAX. 08-583 581 82

BILD	ART.GR.	BENÄMNING	DIN	ISO	KVAL	YTBEH	SIDA
8	7080	MFX, FÖRSÄNK, PH	965	7046	4.8	OBEH.	7:10
8	7080	MFX, FÖRSÄNK, PH	965	7046	A2		7:45
8	7081	MFX, FÖRSÄNK, PH	965	7046	4.8	FZB	7:9
8	7081	MFX, FÖRSÄNK, PH	965	7046	A4		7:45
29	7082	MFT, FÖRSÄNK, STAR	~965	~7046	4.8	OBEH.	7:13
29	7082	MFT, FÖRSÄNK, STAR	~965	~7046	A2		7:48
29	7083	MFT, FÖRSÄNK, STAR	~965	~7046	4.8	FZB	7:13
29	7083	MFT, FÖRSÄNK, STAR	~965	~7046	A4		7:48
29	7084	MFT, FÖRSÄNK, STAR	~965	~7046	8.8	FZB	7:13
9	7090	MFX, FÖRSÄNK, POZI	965	7046	A2		7:45
9	7091	MFX, FÖRSÄNK, POZI	965	7046	4.8	FZB	7:9
9	7091	MFX, FÖRSÄNK, POZI	965	7046	A4		7:45
30	7085	MKFT, KULLERFÖRSÄNK, STAR	~966	~7047	A2		7:49
30	7086	MKFT, KULLERFÖRSÄNK, STAR	~966	~7047	A4		7:49
10	7110	MKFX, KULLERFÖRSÄNK, PH	966	7047	A2		7:46
10	7111	MKFX, KULLERFÖRSÄNK, PH	966	7047	4.8	FZB	7:10
10	7111	MKFX, KULLERSÖRSÄNK, PH	966	7047	A4		7:46
11	7120	MKFX, KULLERFÖRSÄNK, POZI	966	7047	A2		7:46
11	7121	MKFX, KULLERFÖRSÄNK, POZI	966	7047	4.8	FZB	7:10
11	7121	MKFX, KULLERSÖRSÄNK, POZI	966	7047	A4		7:46
6	8011	RXS, KULLRIG, SPETS, PH	7981C	7049C		FZB	8:1
6	8011	RXS, KULLRIG, SPETS, PH	7981C	7049C	A2		8:43
7	8012	RXS, KULLRIG, SPETS, POZI	7981C	7049C		FZB	8:1
7	8012	RXS, KULLRIG, SPETS, POZI	7981C	7049C	A2		8:43
6	8013	RXS, KULLRIG, SPETS, PH	7981C	7049C	A4		8:44
7	8014	RXS, KULLRIG, SPETS, POZI	7981C	7049C	A4		8:44
8	8015	RTS, KULLRIG, SPETS, STAR	7981C	7049C		FZB	8:3
8	8015	RTS, KULLRIG, SPETS, STAR	7981C	7049C	A2		8:45
8	8016	RTS, KULLRIG, SPETS, STAR	7981C	7049C	A4		8:46
9	8020	RXK, KULLRIG, TRUBBIG, PH	7981F	7049F		FZB	8:2
10	8021	RXK, KULLRIG, TRUBBIG, POZI	7981F	7049F		FZB	8:2
11	8023	RTK, TRUBBIG, STAR	7981F	7049F		FZB	8:3
12	8030	FXS, FÖRSÄNK, SPETS, PH	7982C	7050C		FZB	8:1
12	8030	FXS, FÖRSÄNK, SPETS, PH	7982C	7050C	A2		8:43
13	8031	FXS, FÖRSÄNK, SPETS, POZI	7982C	7050C		FZB	8:1
13	8031	FXS, FÖRSÄNK, SPETS, POZI	7982C	7050C	A2		8:43
12	8032	FXS, FÖRSÄNK, SPETS, PH	7982C	7050C	A4		8:44
13	8033	FXS, FÖRSÄNK, SPETS, POZI	7982C	7050C	A4		8:44
14	8034	FTS, FÖRSÄNK, SPETS, STAR	7982C	7050C	A2		8:45
14	8035	FTS, FÖRSÄNK, SPETS, STAR	7982C	7050C		FZB	8:3
14	8035	FTS, FÖRSÄNK, SPETS, STAR	7982C	7050C	A4		8:46
15	8040	KFXS, KULLERFÖRSÄNK, PH	7983C	7051C		FZB	8:1
15	8040	KFXS, KULLERFÖRSÄNK, PH	7983C	7051C	A2		8:43
16	8041	KFXS, KULLERFÖRSÄNK, POZI	7983C	7051C		FZB	8:1
16	8041	KFXS, KULLERFÖRSÄNK, POZI	7983C	7051C	A2		8:43
15	8042	KFXS, KULLERFÖRSÄNK, PH	7983C	7051C	A4		8:44
16	8043	KFXS, KULLERFÖRSÄNK, POZI	7983C	7051C	A4		8:44
17	8048	KFTS, KULLERFÖRSÄNK, STAR	7983C	7051C	A2		8:45
17	8049	KFTS, KULLERFÖRSÄNK, STAR	7983C	7051C		FZB	8:3
17	8049	KFTS, KULLERFÖRSÄNK, STAR	7983C	7051C	A4		8:46
23	3245	LM6MF, FLÄNSLÅSMUTTER	6926	7073	8	FZB	3:9
1	4000	BRB, PLANBRICKA	125	7089	A2		4:40
1	4000	PB, PLANBRICKA	125	7089			4:90
1	4000	RB, PLANBRICKA	125	7089			4:70
1	4000	RB, PLANBRICKA	125	7089			4:80
1	4000	RB, PLANBRICKA	125A	7089			4:110
1	4000	RB, PLANBRICKA	125A	7089			4:116
1	4001	BRB, PLANBRICKA	125	7089	A4		4:40
1	4003	RB, PLANBRICKA	125A	7089	HV200	OBEH.	4:1
1	4004	RB, PLANBRICKA	125A	7089	HV200	FZB	4:1

SWEBOLT AB

TEL. 08-584 909 60 FAX. 08-583 581 82

BILD	ART.GR.	BENÄMNING	DIN	ISO	KVAL	YTBEH	SIDA
1	4005	RB, PLANBRICKA	125A	7089	HV200	FZV	4:1
1	4009	HRB, PLANBRICKA	125A	7089	HV300	OBEH.	4:1
1	4010	HRB, PLANBRICKA	125A	7089	HV300	FZB	4:1
1	4019	BRB, PLANBRICKA		7089	HB200	SVOX.	4:1
1	4000	RB, PLANBRICKA	125A+B	7089/7090			4:60
1	4001	RB, PLANBRICKA	125A+B	7089/7090		FÖRNICKLAD	4:60
1	4032	SRB, PLANBRICKA	126	7091	HV140	OBEH.	4:2
1	4033	SRB, PLANBRICKA	126	7091	HV140	FZB	4:2
1	4034	SRB, PLANBRICKA	126	7091	HV140	FZV	4:2
2	4050	PB, PLANBRICKA	433	7092	HV250	OBEH.	4:9
2	4050	PB, PLANBRICKA	433	7092			4:61
2	4051	PB, PLANBRICKA	433	7092	HV250	FZB	4:9
2	4051	PB, PLANBRICKA	433	7092		FÖRNICKLAD	4:61
2	4053	PB-FRP, PLANBRICKA FÖR FRP	433	7092	A2		4:44
2	4054	PB-FRP, PLANBRICKA FÖR FRP	433	7092	A4		4:44
2	4069	RBS, STOR PLANBRICKA	9021	7093		FZV	4:3
2	4070	RBS, STOR PLANBRICKA	9021	7093		OBEH.	4:3
2	4070	RBS, STOR PLANBRICKA	9021	7093			4:60
2	4070	RBS, STOR PLANBRICKA	9021	7093			4:90
2	4070	RBS, STOR PLANBRICKA	9021	7093			4:70
2	4070	RBS, STOR PLANBRICKA	9021	7093			4:80
2	4071	RBS, STOR PLANBRICKA	9021	7093		FZB	4:3
2	4071	RBS, STOR PLANBRICKA	9021	7093		FÖRNICKLAD	4:60
15	2160	MC6SPB, PASSBULT		7379	12.9	OBEH.	2:33
6	2070	K6S, KULLRIG INSEXSKRUV		7380	10.9	OBEH.	2:23
6	2070	K6S, KULLRIG INSEXSKRUV		7380	A2		2:71
6	2071	K6S, KULLRIG INSEXSKRUV		7380	10.9	FZB	2:24
6	2071	K6S, KULLRIG INSEXSKRUV		7380	A4		2:71
24	2073	SK6S, SÄKERHETSSKRUV m. INV TAPP		~7380	10.9	OBEH.	2:41
24	2073	SK6S, SÄKERHETSSKRUV m. INV TAPP		~7380	A2		2:76
18	2190	KTS, KULLRIG STAR		~7380	10.9	OBEH.	2:37
18	2191	KTS, KULLRIG STAR		~7380	10.9	FZB	2:37
15	1295	HSB, STÅLBYGGNADSBULT	6914	7412	10.9	OBEH.	1:44
15	1296	HSB, STÅLBYGGNADSBULT	6914	7412	10.9	FZB	1:45
15	1297	HSB, STÅLBYGGNADSBULT	6914	7412	10.9	FZV	1:46
1	3040	M6MSB, STÅLBYGGN.MUTTER	6915	7414	10	OBEH.	3:6
1	3041	M6MSB, STÅLBYGGN.MUTTER	6915	7414	10	FZB	3:6
1	3042	M6MSB, STÅLBYGGN.MUTTER	6915	7414	10	FZV	3:6
3	4072	SBB, STÅLBYGGNADSBRICKA	6916	7416	C45	OBEH.	4:3
3	4073	SBB, STÅLBYGGNADSBRICKA	6916	7416	C45	FZB	4:3
3	4074	SBB, STÅLBYGGNADSBRICKA	6916	7416	C45	FZV	4:3
17	7180	SSS, SPETSIG m. SPÅR	553	7434		OBEH.	7:14
17	7180	SSS, SPETSIG m. SPÅR	553	7434	A1		7:54
17	7180	SSS, SPETSIG m. SPÅR	553	7434			7:65
17	7181	SSS, SPETSIG m. SPÅR	553	7434		FZB	7:14
17	7181	SSS, SPETSIG m. SPÅR	553	7434	A4		7:54
18	7190	TSS, TAPP m. SPÅR	417	7435		OBEH.	7:14
18	7190	TSS, TAPP m. SPÅR	417	7435	A2		7:55
18	7191	TSS, TAPP m.SPÅR	417	7435		FZB	7:14
18	7191	TSS, TAPP m. SPÅR	417	7435	A4		7:55
19	7200	SKSS, SKÅLAD m. SPÅR	438	7436		OBEH.	7:14
19	7200	SKSS, SKÅLAD m. SPÅR	438	7436	A2		7:55
19	7201	SKSS, SKÅLAD m. SPÅR	438	7436		FZB	7:14
19	7201	SKSS, SKÅLAD m. SPÅR	438	7436	A4		7:55
3	11010	IGCP, INV. GÄNG CYL. PINNE m6	7979	8735			11:6
3	1140	FM6SH, HELG., FINGÄNGAD		8676	8.8	OBEH.	1:23
3	1141	FM6SH, HELG., FINGÄNGAD		8676	8.8	FZB	1:25
3	1142	FM6SH, HELG., FINGÄNGAD	(961)	8676	10.9	OBEH.	1:27
3	1143	FM6SH, HELG., FINGÄNGAD	(961)	8676	10.9	FZB	1:29
3	1145	FM6SH, HELG., FINGÄNGAD	(961)	8676	12.9	OBEH.	

SWEBOLT AB

TEL. 08-584 909 60 FAX. 08-583 581 82

BILD	ART.GR.	BENÄMNING	DIN	ISO	KVAL	YTBEH	SIDA
3	1150	FM6SH, UDDA LÄNGDER, HELG.	961	8676	8.8	OBEH.	1:23
3	1151	FM6SH, UDDA LÄNGDER, HELG.	961	8676	8.8	FZB	1:25
4	1152	FM6SH, UDDA LÄNGDER, HELG.	961	8676	10.9	OBEH.	1:27
4	1153	FM6SH, UDDA LÄNGDER, HELG.	961	8676	10.9	FZB	1:29
1	10001	MVBF, VAGNSBULT	603	8677	4.6	OBEH.	10:1
1	10001	MVBF, VAGNSBULT	603	8677	A2		10:41
1	10001	MVBF, VAGSBULT	603	8677			10:60
1	10002	MVBF, VAGNSBULT	603	8677	4.6	FZB	10:1
1	10002	MVBF, VAGNSBULT	603	8677	A4		10:41
1	10003	MVBF, VAGNSBULT	603	8677	4.6	FZV	10:7
1	10004	MVBF, VAGNSBULT	603	8677	8.8	OBEH.	10:8
1	10005	MVBF, VAGNSBULT	603	8677	8.8	FZB	10:8
1	10006	MVBF, VAGNSBULT	603	8677	8.8	FZV	10:8
2	11003	CPK, HÄRDAD CYL. PINNE m6	6325	8734	STÅL		11:2
2	11004	CPK, HÄRDAD CYL. PINNE h6	6325	8734	STÅL		11:2
5	11030	IGKP, KONISK, INV. GÄNGA h10	7978	8736			11:14
6	11055	GKP, GÄNG KONISK PINNE	7977	8737			11:7
7	11060	RPC, RÄFFELPINNE	1470	8739			11:8
10	11090	RP, RÄFFELPINNE	1473	8740			11:9
11	11100	RPE, RÄFFELPINNE	1474	8741			11:9
12	11110	RPD, RÄFFELPINNE	1475	8742			11:9
8	11070	RPA, RÄFFELPINNE	1471	8744			11:8
9	11080	RPB, RÄFFELPINNE	1472	8745			11:8
32	13040	KNR, KULLRIG NIT, RÄFFLAD	1476	8746			
14	11135	PRYM, SPIRALSPÄNNSTIFT, KRAFTIG	7344	8748			11:10
14	11130	PRYM, SPIRALSPÄNNSTIFT	7343	8750			11:6
14	11130	PRYM, SPIRALSPÄNNSTIFT	7343	8750	1.4310		11:45
13	11120	FRP, FJÄDRANDE RÖRPINNE	1481	8752			11:3-11:4
13	11120	FRP, FJÄDRANDE RÖRPINNE	1481	8752	A2		11:41
4	1140	FM6S, DELG., FINGÄNGAD		8765	8.8	OBEH.	1:24
4	1141	FM6S, DELG., FINGÄNGAD		8765	8.8	FZB	1:26
4	1142	FM6S, DELG., FINGÄNGAD	(960)	8765	10.9	OBEH.	1:28
4	1143	FM6S, DELG., FINGÄNGAD	(960)	8765	10.9	FZB	1:30
4	1145	FM6S, DELG., FINGÄNGAD	(960)	8765	12.9	OBEH.	
13	11125	FRP, FJÄDRANDE PINNE ENKEL	7346	~13337			11:5

SWEBOLT AB

TEL. 08-584 909 60 FAX. 08-583 581 82

BOOKSTAVSORDNING A-Ö

6	4110	4BB, STOR FYRKANTBRICKA				OBEH.	4:8
6	4111	4BB, STOR FYRKANTBRICKA				FZB	4:8
6	4112	4BB, STOR FYRKANTBRICKA				FZV	4:8
23	10160	4-KANT m. TAPP OCH FLÄNS	480		8.8	OBEH.	10:21
23	10165	4-KANT m. TAPP OCH FLÄNS	480		10.9	OBEH.	10:21
45	3820	4-KANT SKARVMUTTER			A2		3:48
45	3821	4-KANT SKARVMUTTER			A4		3:48
14	1320	6HS, HÅLSKRUV	7623A			OBEH.	1:55
14	1321	6HS, HÅLSKRUV, 2-VÄGS	7623C			OBEH.	1:56
13	2140	6-KANT-NYCKEL m. TAPP	6911			OBEH.	2:32
13	2141	6-KANT-NYCKEL m. TAPP	6911			FZB	2:32
12	2130	6KN, 6-KANT-NYCKEL	911	2936		OBEH.	2:31
12	2131	6KN, 6-KANT-NYCKEL	911	2936		FZB	2:31
12	2132	6KN, 6-KANT-NYCKEL	911		HÄRDAD	OBEH.	2:31
12	2133	6KN, 6-KANT-NYCKEL	911		HÄRDAD	FZB	2:31
12	2136	6KN, 6-KANT-NYCKEL m. INV HÅL för SÄKERHETSSKRUV	~911	2936		STÅL	2:32
	2134	6KN, 6-KANT-NYCKEL, LÅNG	911			OBEH.	2:31
	2135	6KN, 6-KANT-NYCKEL, LÅNG	911			FZB	2:31
30	4235	ABA, ANSLUTNINGBRICKA	46288A			OBEH.	4:9
30	4236	ABA, ANSLUTNINGBRICKA	46288A			FZB	4:9
31	4240	ABB, ANSLUTNINGBRICKA	46288B			OBEH.	4:9
31	4241	ABB, ANSLUTNINGBRICKA	46288B			FZB	4:9
3	5020	AK, LÅSRING m. LÄPP, HÅL	983			OBEH.	5:6
32		ANKARPINNAR, SE FLIK 6 PINNSKRUVAR					
32		ANKARPINNAR, SE FLIK 6 PINNSKRUVAR					
9	6300	ANKARPINNE / SNEDKAPAD			4.6	OBEH.	6:12
9	6300	ANKARPINNE / SNEDKAPAD			A2		6:42
9	6301	ANKARPINNE / SNEDKAPAD			4.6	FZB	6:12
9	6301	ANKARPINNE / SNEDKAPAD			A4		6:42
9	6305	ANKARPINNE / SNEDKAPAD			5.8	OBEH.	6:12
9	6306	ANKARPINNE / SNEDKAPAD			5.8	FZB	6:12
9	6307	ANKARPINNE / SNEDKAPAD			5.8	FZV	6:12
9	6310	ANKARPINNE / SNEDKAPAD			8.8	OBEH.	6:12
9	6311	ANKARPINNE / SNEDKAPAD			8.8	FZB	6:12
9	6312	ANKARPINNE / SNEDKAPAD			8.8	FZV	6:12
25	15585	ANKARSKRUV				FZB	15:10
23	7240	AS, ANSATSSKRUV	923			OBEH.	7:17
10	5060	AS, LÅSRING, AXEL				OBEH.	5:8
10	5061	AS, LÅSRING, AXEL				FZB	5:8
32	7250	ASL, ANSATSSKRUV, LITEN SKA.	920			OBEH.	7:19
14	5300	ASL, AXELSÄKRINGSLÅS (STARLOCK-QUICKLOCK)				OBEH.	5:5
14	5301	ASL, AXELSÄKRINGSLÅS (STARLOCK-QUICKLOCK)				FZB	5:5
14	5300	ASL, AXELSÄKRINGSLÅS (STARLOCK - QUICKLOCK)			A2		5:41
15	5302	ASLK, AXELSÄKRINGSLÅS m. KAPSEL			A2		5:41
15	5302	ASLK, AXELSÄKRINGSLÅS MED KAPSEL				OBEH.	5:5
15	5303	ASLK, AXELSÄKRINGSLÅS MED KAPSEL				FZB	5:5
6	5035	AV, LÅSRING, AXEL				OBEH.	5:6
12	14320	AVGASKLAMMER				OBEH.	14:4
12	14321	AVGASKLAMMER				FZB	14:4
1	3062	B6M, SEXKANTMUTTER	WITHW+BSF		8	OBEH.	3:32
1	3063	B6M, SEXKANTMUTTER	WITHW+BSF		8	FZB	3:32
1	3064	B6M, SEXKANTMUTTER	WITHW+BSF		8	FZV	3:32
21	5330	BF, BRICKFJÄDER				OBEH.	5:12
5	68080	BITS, INVÄNDIG 6-KANT			EXTRA HÅRD	GRÅ	18:2
3	68040	BITS, MEJSEL			SEGHÄRDAD	SVART	18:1
3	68050	BITS, MEJSEL			EXTRA HÅRD	GRÅ	18:1

SWEBOLT AB

TEL. 08-584 909 60 FAX. 08-583 581 82

BILD	ART.GR.	BENÄMNING	DIN	ISO	KVAL	YTBEH	SIDA
1	68000	BITS, PH, PHILIPS			SEGHÄRDAD	SVART	18:1
1	68010	BITS, PH, PHILIPS			EXTRA HÅRD	GRÅ	18:1
2	68020	BITS, POZI			SEGHÄRDAD	SVART	18:1
2	68030	BITS, POZI			EXTRA HÅRD	GRÅ	18:1
4	68070	BITS, STAR			EXTRA HÅRD	GRÅ	18:2
41	10470	BLADHYLSA				OBEH.	10:5
41	10471	BLADHYLSA				FZB	10:5
	13950	BLINDNITSTÅNG, BM 65					13:86
	13951	BLINDNITSTÅNG, BM 66					13:87
	13952	BLINDNITSTÅNG, BM 67					13:88
	13953	BLINDNITSTÅNG, BM 90					13:89
	13954	BLINDNITSTÅNG, BM 92					13:90
	13955	BLINDNITSTÅNG, BM 93					13:91
	13956	BLINDNITSVERKTYG, EL					13:92
	13957	BLINDNITSVERKTYG, LUFT					13:93
13	61000	BORR, CYLINDRISK, Nr. 100	338	235/1	STÅL	HSS	18:20
14	61300	BORR, KONISK, Nr. 130	345	235/1	STÅL	HSS	18:22
15	61200	BORR, KORT, Nr. 120	1897	235/1	STÅL	HSS	18:23
16	61210	BORR, KORT, VÄNSTER, Nr. 120V	1897	235/1	STÅL	HSS	18:24
17	61100	BORR, LÅNG, Nr. 110	340		STÅL	HSS	18:25
1	4000	BRB, PLANBRICKA			HB200	OBEH.	4:1
1	4000	BRB, PLANBRICKA	125	7089	A2		4:40
1	4001	BRB, PLANBRICKA			HB200	FZB	4:1
1	4001	BRB, PLANBRICKA	125	7089	A4		4:40
1	4002	BRB, PLANBRICKA			HB200	FZV	4:1
1	4019	BRB, PLANBRICKA		7089	HB200	SVOX.	4:1
1	4011	BRFB, RUND FASAD BRICKA			HB200	OBEH.	4:2
1	4012	BRFB, RUND FASAD BRICKA			HB200	FZB	4:2
1	4013	BRFB, RUND FASAD BRICKA			HB200	FZV	4:2
29	10230	BS, BLADSKRUV				OBEH.	10:16
29	10230	BS, BLADSKRUV				FZB	10:16
3-4	1168	BSF-SAE OCH ANDRA GÄNGOR PÅ BEGÄRAN					
19	8051	BSK, 6-KANT, TRUBBIG	7976F	1479F		FZB	8:5
18	8050	BSS, 6-KANT, SPETSIG	7976C	1479C		FZB	8:5
18	8050	BSS, 6-KANT, SPETSIG	7976C	1479C	A2		8:49
47	8351	BSSB, 6-KANT, SPETSIG, OFÖRLORBAR BRICKA				FZB	8:18
20	8056	BSSF, 6-KANT MED FLÄNS + SPÅR				FZB	8:5
25	9380	BST, BLADSKRUV, TRÄGÄNGA				OBEH.	9:13
25	9381	BST, BLADSKRUV, TRÄGÄNGA				FZB	9:13
32	4245	BUH, BRICKA UTAN HÅL				OBEH.	4:17
32	4245	BUH, BRICKA UTAN HÅL			A2		4:50
32	4246	BUH, BRICKA UTAN HÅL				FZB	4:17
57	4402	BULLDOGBRICKA, DUBBEL				FZV	4:20
58	4407	BULLDOGBRICKA, ENKEL				FZV	4:20
59	4412	BULLDOGBRICKA, FYRKANT				FZV	4:20
16	11140	CBH, CYL. SKALLBULT	1434				11:12
15	11138	CONEX					11:11
1	11000	CP, CYL. PINNE	h8	7	2338	STÅL	11:1
1	11001	CP, CYL. PINNE	m6	7	2338	STÅL	11:1
1	11001	CP, CYL. PINNE	m6	7	2338	A2	11:42
1	11002	CP, CYL. PINNE	h6	7	2338	STÅL	11:3
1	11002	CP, CYL. PINNE	h8	7	2338	A1	11:42
1	11003	CP, CYL. PINNE	m6	7	2338	A4	11:43
1	11004	CP, CYL. PINNE	h8	7	2338	A4	11:43
2	11003	CPK, HÄRDAD CYL. PINNE	m6	6325	8734	STÅL	11:2
2	11004	CPK, HÄRDAD CYL. PINNE	h6	6325	8734	STÅL	11:2
2	8004	CSK, CYL. SKALLE, TRUBBIG	7971F	1481F		FZB	8:2
1	8000	CSS, CYL. SKALLE, SPETS	7971C	1481			8:70
1	8000	CSS, CYL. SKALLE, SPETS	7971C	1481C	A2		8:41
1	8001	CSS, CYL. SKALLE, SPETS	7971C	1481C		FZB	8:4

SWEBOLT AB

TEL. 08-584 909 60 FAX. 08-583 581 82

BILD	ART.GR.	BENÄMNING	DIN	ISO	KVAL	YTBEH	SIDA
1	8001	CSS, CYL. SKALLE, SPETS	7971C	1481C	A4		8:42
1	17001	DHM, DISTANSHYLSA				FÖRNICKLAD	17:10
1	17000	DHPP, DISTANSHYLSA			POLYAMID PA 6.0		17:13
1	17001	DHR, DISTANSHYLSA			A2		17:5
35	4125	DIB, DUBBELSIDIG TANDBRICKA				OBEH.	4:18
35	4126	DIB, DUBBELSIDIG TANDBRICKA				FZB	4:18
1	17020	DISTANS, RUND			NATUR		17:19
1	17021	DISTANS, RUND			VIT		17:19
1	17022	DISTANS, RUND			SVART		17:19
1	17023	DISTANS, RUND			RÖD		17:19
1	17024	DISTANS, RUND			GRÖN		17:19
3	14020	DLN, DUBBEL LÅSNÅL	11024			FZB	14:2
26	9390	DLSS, DUBBEL LEDSTÅNGSSKRUV				OBEH.	9:13
26	9391	DLSS, DUBBEL LEDSTÅNGSSKRUV				FZB	9:13
4	17008	DMM, DISTANS, 6-KANT				FÖRNICKLAD	17:11
4	17008	DMNP, DISTANSMUTTER, 6-KANT			POM-4		17:17
4	17009	DMNP, DISTANSMUTTER, 6-KANT			PPS SVART		17:15
4	17010	DMNP, DISTANSMUTTER, 6-KANT			POLYAMID PA 6.0 SVART		17:16
2	17003	DMP, DISTANSMUTTER			POM-H		17:14
4	17008	DMR, DISTANSMUTTER, 6-KANT			A2		17:6
4	17007	DMRO, DISTANDMUTTER, 6-KANT			A2	OMAGNETISK	17:7
2	17003	DMRS, DISTANSMUTTER, RUND				FZG	17:3
4	17008	DHS, DISTANSMUTTER, 6-KANT				FZG	17:1
26	15690	DRIVA					15:11
43	10028	DS, DRAGSKRUV				FZB	10:13
5	17011	DSM, DISTANSSKRUV, 6-KANT				FÖRNICKLAD	17:12
5	17011	DSP, DISTANSSKRUV, 6-KANT			POLYAMID PA 6.0		17:18
5	17011	DSR, DISTANSSKRUV, 6-KANT			A2		17:8
5	17012	DSRO, DISTANSSKRUV, 6-KANT			A2	OMEGNETISK	17:9
3	17005	DSRS, DISTANSSKRUV				FZG	17:4
5	17011	DSS, DISTANSSKRUV, 6-KANT				FZG	17:2
20	62100	DUBBHÅLSBORR, Nr. 210	333R	2541	STÅL	HSS	18:27
28	4225	EB, ENDBRICKA	470			OBEH.	4:17
28	4226	EB, ENDBRICKA	470			FZB	4:17
1-2	2020	EC6S, INSEXSKRUV		WITHW+BSF	12.9	OBEH.	2:45
33	7101	ECO-FIX, RUNDAT HUVUD m. FLÄNS PH			A2		7:53
33	7101	ECO-FIX, RUNDAT HUVUD m. FLÄNS, PH				FZB	7:11
44	8336	ECSS, ENVÄGS, CYL SKALLE			A2		8:50
44	8336	ECSS, ENVÄGS, CYL-SKALLE				FZB	8:17
17	13650	EKBL-AL/ST	ALU		STÅL		13:56
33	10400	ELEVATORSK., INKL. MUTTER o. BRICKA				FZB	10:32
35	10410	ELEVATORSK., LÅSTAPP MED MUTTER o. BRICKA				FZB	10:33
34	10405	ELEVATORSK., MED NIBB				FZB	10:32
36	10415	ELEVATORSK., MUTTER+LÅSTAPP				FZB	10:33
29	15650	EPOMIX, TUB	160ml				15:2
29	15651	EPOMIX, TUB	360ml				15:2
9	13380	ESKBL-AL/ST	ALU		STÅL		13:44
1	15001	EXPANDER			A4		15:1
1	15001	EXPANDERBULT				FZB	15:1
1	15002	EXPANDERBULT				FZV	15:1
12	15500	FAS, FARMARSKRUV, SPETSIG				FZB	15:5
12	15501	FAS, FARMARSKRUV, SPETSIG				VIT	15:5
12	15502	FAS, FARMARSKRUV, SPETSIG				SVART	15:5
12	15503	FAS, FARMARSKRUV, SPETSIG				BRUN	15:5
12	15504	FAS, FARMARSKRUV, SPETSIG				GRÅ	15:5
12	15505	FAS, FARMARSKRUV, SPETSIG				RÖD	15:5
17	15415	FASADPLUGG					15:7
13	15520	FASB, FARMARSKRUV, BORRSPETS				FZB	15:5
13	15521	FASB, FARMARSKRUV, BORRSPETS				VIT	15:5

SWEBOLT AB

TEL. 08-584 909 60 FAX. 08-583 581 82

BILD	ART.GR.	BENÄMNING	DIN	ISO	KVAL	YTBEH	SIDA
13	15522	FASB, FARMARSKRUV, BORRSPETS				SVART	15:5
13	15523	FASB, FARMARSKRUV, BORRSPETS				BRUN	15:5
13	15524	FASB, FARMARSKRUV, BORRSPETS				GRÅ	15:5
13	15525	FASB, FARMARSKRUV, BORRSPETS				RÖD	15:5
14	15540	FASP, FARMARSKRUV, PLAN				FZB	15:5
14	15541	FASP, FARMARSKRUV, PLAN				VIT	15:5
14	15542	FASP, FARMARSKRUV, PLAN				SVART	15:5
14	15543	FASP, FARMARSKRUV, PLAN				BRUN	15:5
14	15544	FASP, FARMARSKRUV, PLAN				GRÅ	15:5
14	15545	FASP, FARMARSKRUV, PLAN				RÖD	15:5
10	4138	FB, CUVETTBRICKA (ROSETTBR)				FÖRNICKLAD	4:61
10	4135	FB, FÖRSÄNKT BRICKA 90°, 110°				OBEH.	4:12
10	4135	FB, FÖRSÄNKT BRICKA 90°, 110°			A2		4:46
10	4135	FB, FÖRSÄNKT BRICKA 90°, 110°				SVART	4:93
10	4135	FB, FÖRSÄNKT BRICKA 90°, 110°					4:71
10	4135	FB, FÖRSÄNKT BRICKA 90°, 110°					4:81
10	4136	FB, FÖRSÄNKT BRICKA 90°, 110°				FZB	4:12
10	4136	FB, FÖRSÄNKT BRICKA 90°, 110°			A4		4:46
10	4136	FB, FÖRSÄNKT BRICKA 90°, 110°				NATUR	4:93
10	4137	FB, FÖRSÄNKT BRICKA 90°, 110°				VIT	4:93
10	4138	FB, FÖRSÄNKT BRICKA 90°, 110°				GRÖN	4:93
10	4139	FB, FÖRSÄNKT BRICKA 90°, 110°				RÖD	4:93
10	4138	FB, FÖRSÄNKT BRICKA, ROSETT			A2		4:46
11	4140	FBB, FJÄDERBRICK	127				4:120
11	4140	FBB, FJÄDERBRICKA	127B			OBEH.	4:5
11	4140	FBB, FJÄDERBRICKA	127B		A2		4:41
11	4140	FBB, FJÄDERBRICKA	127				4:72
11	4140	FBB, FJÄDERBRICKA	~127				4:81
11	4141	FBB, FJÄDERBRICKA	127B			FZB	4:5
11	4141	FBB, FJÄDERBRICKA	127B		A4		4:41
11	4142	FBB, FJÄDERBRICKA	127B			FZV	4:5
12	4145	FBH, FJÄDERBRICKA	128A			OBEH.	4:5
12	4145	FBH, FJÄDERBRICKA	128A		A2		4:48
12	4146	FBH, FJÄDERBRICKA	128A			FZB	4:5
12	4146	FBH, FJÄDERBRICKA	128A		A4		4:48
14	13500	FBL-AL/ST	ALU		STÅL		13:15
14	13512	FBL-AL/ST, SVART	ALU		STÅL	5010	13:20
14	13511	FBL-AL/ST, VIT	ALU		STÅL	9010	13:19
14	13503	FBL-KO/RF	KOPPAR		ROSTFRI		13:18
14	13502	FBL-KO/ST	KOPPAR		STÅL		13:17
15	13510	FBLMG-AL/ST	ALU		STÅL		13:48
15	13511	FBLMG-AL/ST, SVART	ALU		STÅL	5010	13:49
14	13501	FBL-ST/ST	STÅL		STÅL		13:16
14	13520	FBLU-AL/ST	ALU		STÅL		13:57
14	13521	FBLU-KO/ST	KOPPAR		STÅL		13:58
14	13522	FBLU-ST/ST	STÅL		STÅL		13:59
22	13772	FBMSAL, FÖRSÄNKT SLUTEN			ALU		13:75
24	13755	FBMSS, FÖRSÄNKT SKALLE, SLUTEN			STÅL	OBEH.	13:73
24	13756	FBMSS, FÖRSÄNKT SKALLE, SLUTEN			STÅL	FZG	13:73
24	13757	FBMSS, FÖRSÄNKT SKALLE, SLUTEN			STÅL	FZB	13:73
24	11776	FBMSSAL, FÖRSÄNKT SLUTEN SMALLGRIP			ALU		13:75
24	13765	FBMSSS, FÖRSÄNKT SKA. SMALLGRIP, SLUTEN			STÅL	OBEH.	13:74
24	13766	FBMSSS, FÖRSÄNKT SKA. SMALLGRIP, SLUTEN			STÅL	FZG	13:74
24	13767	FBMSSS, FÖRSÄNKT SKA. SMALLGRIP, SLUTEN			STÅL	FZB	13:74
21	13770	FBMÖAL, FÖRSÄNKT ÖPPEN			ALU		13:75
26	13855	FBMÖRS, FÖRSÄNKT SKALLE, RILLAD, ÖPPEN			STÅL	OBEH.	13:78
26	13856	FBMÖRS, FÖRSÄNKT SKALLE, RILLAD, ÖPPEN			STÅL	FZG	13:78
26	13857	FBMÖRS, FÖRSÄNKT SKALLE, RILLAD, ÖPPEN			STÅL	FZB	13:78
23	13780	FBMÖRS, FÖRSÄNKT ÖPPEN			ROSTFRI		13:76
23	13750	FBMÖS, FÖRSÄNKT SKALLE, ÖPPEN			STÅL	OBEH.	13:73

SWEBOLT AB

TEL. 08-584 909 60 FAX. 08-583 581 82

BILD	ART.GR.	BENÄMNING	DIN	ISO	KVAL	YTBEH	SIDA
23	13751	FBMÖS, FÖRSÄNKT SKALLE, ÖPPEN			STÅL	FZG	13:73
23	13752	FBMÖS, FÖRSÄNKT SKALLE, ÖPPEN			STÅL	FZB	13:73
23	13774	FBMÖSAL, FÖRSÄNKT ÖPPEN SMALLGRIP			ALU		13:75
23	13782	FBMÖSRS, FÖRSÄNKT ÖPPEN SMALLGRIP			ROSTFRI		13:76
23	13760	FBMÖSS, FÖRSÄNKT SKA. SMALLGRIP, ÖPPEN			STÅL	OBEH.	13:74
23	13761	FBMÖSS, FÖRSÄNKT SKA. SMALLGRIP, ÖPPEN			STÅL	FZG	13:74
23	13762	FBMÖSS, FÖRSÄNKT SKA. SMALLGRIP, ÖPPEN			STÅL	FZB	13:74
11	4143	FBR, FJÄDERBRICKA	7980		A2		4:43
11	4144	FBR, FJÄDERBRICKA	7980		A4		4:43
11	4143	FBR, FJÄDERBRICKA f. INSEX	7980			OBEH.	4:10
11	4144	FBR, FJÄDERBRICKA f. INSEX	7980			FZB	4:10
5	3127	FHLM6M, HELMET. FINGÄNGA	980	7042	10	FZB	3:4
3	3102	FLM6M, FINGÄNGAD LÅSM.	985		8	FZB	3:8
3	3107	FLM6M, FINGÄNGAD LÅSM.	985		10	FZB	3:8
4	3116	FLM6MM, FINGÄNGA, NYLOCK	~982		8	FZB	3:19
22	7230	FLSS, FLATSKALLIG SPÅRSKRUV	921			OBEH.	7:12
22	7230	FLSS, FLATSKALLIG SPÅRSKRUV	921				7:66
22	7231	FLSS, FLATSKALLIG SPÅRSKRUV	921			FZB	7:12
3	3106	FLU6M, NYLONLÅSMUTTER	UNF		8	FZB	3:31
4	3111	FLU6MH, HÖG LÅSMUTTER	UNF		8	FZB	3:31
44	3530	FM, FJÄDERMUTTER, KORT				FZB	3:28
44	3531	FM, FJÄDERMUTTER, LÅNG				FZB	3:28
1	3030	FM6M, FINGÄNGA	934		8	OBEH.	3:7
1	3031	FM6M, FINGÄNGA	934		8	FZB	3:7
1	3032	FM6M, FINGÄNGA	970	4032	8	OBEH.	3:7
1	3033	FM6M, FINGÄNGA	970	4032	8	FZB	3:7
1	3034	FM6M, FINGÄNGA	934		10	OBEH.	3:7
1	3035	FM6M, FINGÄNGA	934		10	FZB	3:7
1	3036	FM6M, FINGÄNGA	970	4032	10	OBEH.	3:7
1	3030	FM6M, SEXKANTMUTTER, FING.			A2		3:43
1	3031	FM6M, SEXKANTMUTTER, FING.			A4		3:43
4	1140	FM6S, DELG., FINGÄNGAD		8765	8.8	OBEH.	1:24
4	1141	FM6S, DELG., FINGÄNGAD		8765	8.8	FZB	1:26
4	1142	FM6S, DELG., FINGÄNGAD	(960)	8765	10.9	OBEH.	1:28
4	1143	FM6S, DELG., FINGÄNGAD	(960)	8765	10.9	FZB	1:30
4	1145	FM6S, DELG., FINGÄNGAD	(960)	8765	12.9	OBEH.	
5	1174	FM6SF, 6-KANT MED FLÄNS, FING.			8.8	OBEH.	1:35
5	1175	FM6SF, 6-KANT MED FLÄNS, FING.			8.8	FZB	1:36
3	1140	FM6SH, HELG., FINGÄNGAD		8676	8.8	OBEH.	1:23
3	1141	FM6SH, HELG., FINGÄNGAD		8676	8.8	FZB	1:25
3	1142	FM6SH, HELG., FINGÄNGAD	(961)	8676	10.9	OBEH.	1:27
3	1143	FM6SH, HELG., FINGÄNGAD	(961)	8676	10.9	FZB	1:29
3	1145	FM6SH, HELG., FINGÄNGAD	(961)	8676	12.9	OBEH.	
3	1150	FM6SH, UDDA LÄNGDER, HELG.	961	8676	8.8	OBEH.	1:23
3	1151	FM6SH, UDDA LÄNGDER, HELG.	961	8676	8.8	FZB	1:25
4	1152	FM6SH, UDDA LÄNGDER, HELG.	961	8676	10.9	OBEH.	1:27
4	1153	FM6SH, UDDA LÄNGDER, HELG.	961	8676	10.9	FZB	1:29
1-2	2013	FMC6S, INSEXSKRUV, FING.	912	4762	8.8	OBEH.	2:9
1-2	2014	FMC6S, INSEXSKRUV, FING.	912	4762	8.8	FZB	2:9
1-2	2015	FMC6S, INSEXSKRUV, FING.	912	4762	12.9	OBEH.	2:12
8	3172	FMHM, FING. HATTMUTTER	1587			OBEH.	3:21
8	3173	FMHM, FING. HATTMUTTER	1587			FZB	3:21
6	3140	FMKM, FING. KRONMUTTER	935		8	OBEH.	3:9
6	3141	FMKM, FING. KRONMUTTER	935		8	FZB	3:9
2	3075	FML6M, FINGÄNGA	936/439B	4035	6	OBEH.	3:8
2	3076	FML6M, FINGÄNGA	936/439B	4035	6	FZB	3:8
2	3086	FML6M, LÅGMUTTER, FING.	439	4035	A4		3:40
10	3187	FMLHM, FING. L. HATTMUTTER	917		6	OBEH.	3:21
10	3188	FMLHM, FING. L. HATTMUTTER	917		6	FZB	3:21
7	3158	FMLKM, LÅG KRONMU., FING.	937		8	OBEH.	3:20

SWEBOLT AB

TEL. 08-584 909 60 FAX. 08-583 581 82

BILD	ART.GR.	BENÄMNING	DIN	ISO	KVAL	YTBEH	SIDA
7	3159	FMLKM,LÅG KRONMU., FING.	937		8	FZB	3:20
4	13010	FN, FÖRSÄNKTK NIT	661		STÅL	OBEH.	13:101
4	13010	FN, FÖRSÄNKTK NIT	661		A2		13:111
4	13010	FN, FÖRSÄNKTK NIT	661				13:121
4	13010	FN, FÖRSÄNKTK NIT	661				13:131
4	13010	FN, FÖRSÄNKTK NIT	~661				13:142
4	13011	FN, FÖRSÄNKTK NIT	661		A4		13:111
32		FNR, RÄFLAD FÖRSÄNKTK NIT	1477		STÅL		13:107
29	4230	FR, FJÄDERRING KONISK	74361C			OBEH.	4:9
29	4231	FR, FJÄDERRING KONISK	74361C			FZB	4:9
13	11125	FRP, FJÄDRANDE PINNE ENKEL	7346	~13337			11:5
13	11120	FRP, FJÄDRANDE RÖRPINNE	1481	8752			11:3-11:4
13	11120	FRP, FJÄDRANDE RÖRPINNE	1481	8752	A2		11:41
16	10088	FS, FÖRSLUTNINGSSKRUV					10:70
4	8007	FSK, FÖRSÄNKTK, TRUBBIG	7972F	1482F		FZB	8:1
3	8005	FSS, FÖRSÄNKTK, SPETS	7972C	1482C	A2		8:41
3	8006	FSS, FÖRSÄNKTK, SPETS	7972C	1482C		FZB	8:4
3	8006	FSS, FÖRSÄNKTK, SPETS	7972C	1482C	A4		8:42
26	8072	FTB, FÖRSÄNKTK, STAR	7504P			FZB	8:14
14	8034	FTS, FÖRSÄNKTK, SPETS, STAR	7982C	7050C	A2		8:45
14	8035	FTS, FÖRSÄNKTK, SPETS, STAR	7982C	7050C		FZB	8:3
14	8035	FTS, FÖRSÄNKTK, SPETS, STAR	7982C	7050C	A4		8:46
1	3055	FU6M, SEXKANTMUTTER	UNF		8	OBEH.	3:31
1	3056	FU6M, SEXKANTMUTTER	UNF		8	FZB	3:31
	1160	FU6S, 6-KANT	UNF		A2		1:78
	1161	FU6S, 6-KANT	UNF		A4		1:78
3-4	1160	FU6S, UNF-GÄNGA, FINGÄNGAD	B 18.2.1		8.8	OBEH.	1:63
3-4	1161	FU6S, UNF-GÄNGA, FINGÄNGAD	B 18.2.1		8.8	FZB	1:64
1-2	2012	FUC6S, INSEXSKRUV	UNF		A2		2:78
1-2	2013	FUC6S, INSEXSKRUV	UNF		A4		2:79
1-2	2019	FUC6S, INSEXSKRUV	UNF		12.9	OBEH.	2:45
3	2038	FUF6S, FÖRSÄNKTK INSEXSKRUV	UNF		10.9	OBEH.	2:46
8	3180	FUHM, HATTMUTTER	UNF		6	OBEH.	3:33
8	3181	FUHM, HATTMUTTER	UNF		6	FZB	3:33
6	2077	FUK6S, KULLRIG INSEXSKRUV	UNF		10.9	OBEH.	2:48
6	3160	FUKM, KRONMUTTER	UNF		8	OBEH.	3:35
6	3161	FUKM, KRONMUTTER	UNF		8	FZB	3:35
2	3095	FUL6M, LÅG SEXKANTMUTTER	UNF		6	OBEH.	3:31
5	2065	FULC6S, LÅG INSEXSKRUV	UNF		12.9	OBEH.	2:47
8	2087	FUP6SS, STOPPSKRUV PLAN	UNF		45HRC	OBEH.	2:50
9	2097	FUS6SS, STOPPS. m. SPETS	UNF		45HRC	OBEH.	2:50
11	2117	FUSK6SS, STOPPSK. SKÅLAD	UNF		45HRC	OBEH.	2:50
10	2107	FUT6SS, STOPPSKRUV m. TAPP	UNF		45HRC	OBEH.	2:50
24	8070	FXB, FÖRSÄNKTK, PH	7504P			FZB	8:13
25	8071	FXB, FÖRSÄNKTK, POZI	7504P			FZB	8:13
12	8030	FXS, FÖRSÄNKTK, SPETS, PH	7982C	7050C		FZB	8:1
12	8030	FXS, FÖRSÄNKTK, SPETS, PH	7982C	7050C	A2		8:43
12	8032	FXS, FÖRSÄNKTK, SPETS, PH	7982C	7050C	A4		8:44
13	8031	FXS, FÖRSÄNKTK, SPETS, POZI	7982C	7050C		FZB	8:1
13	8031	FXS, FÖRSÄNKTK, SPETS, POZI	7982C	7050C	A2		8:43
13	8033	FXS, FÖRSÄNKTK, SPETS, POZI	7982C	7050C	A4		8:44
45	3820	FYRKANT SKARVMUTTER				OBEH.	3:12
45	3821	FYRKANT SKARVMUTTER				FZB	3:12
45	3822	FYRKANT SKARVMUTTER				FZV	3:12
37	10420	FÖRSÄNKTK ELEVATORSK., MUTTER+LÅSTAPP				FZB	10:33
5	10035	FÖRSÄNKTK m. TVÅ KNASTER	25195			OBEH.	10:13
5	10036	FÖRSÄNKTK m. TVÅ KNASTER	25195			FZB	10:13
38	10430	GAFFELLÄNK	71752			OBEH.	10:34
1	17000	GI, GÄNGINSATS, SJÄLVG.				FZG	16:1

SWEBOLT AB

TEL. 08-584 909 60 FAX. 08-583 581 82

BILD	ART.GR.	BENÄMNING	DIN	ISO	KVAL	YTBEH	SIDA
1	17000	GI, GÄNGINSATS, SJÄLVG.					16:1
27	15605	GIPSANKARE (MOLLY TYP)					15:12
2	17002	GIS, SJÄLVG. m. SPÅNUTRYMME	KORT			FZG	16:1
2	17003	GIS, SJÄLVG. m. SPÅNUTRYMME	LÅNG			FZG	16:1
3	17005	GIS3, SJÄLVG. m. SPÅNUTRYMME	KORT			FZG	16:2
3	17006	GIS3, SJÄLVG. m. SPÅNUTRYMME	LÅNG			FZG	16:2
4	17008	GIT, GÄNGINSATS FÖR TERMOPLAST					16:4
5	17010	GITP, GÄNGINSATS FÖR TRÄ OCH PLAST					16:4
6	11040	GKP, GÄNG KONISK PINNE	258				11:7
6	11055	GKP, GÄNG KONISK PINNE	7977	8737			11:7
5	15100	GSI, GIPSSKRUV f. STÅLREGEL				FOS	15:3
5	15101	GSI, GIPSSKRUV f. STÅLREGEL				FZB	15:3
6	15111	GSII, GIPSSKRUV m. BORRSPETS				FOS	15:3
6	15112	GSII, GIPSSKRUV m. BORRSPETS				FZB	15:3
7	15105	GSIII, GIPSSKRUV f. TRÄREGEL				FOS	15:3
7	15106	GSIII, GIPSSKRUV f. TRÄREGEL				FZB	15:3
26	7270	GÄNGAD PINNE MED TAPP	926			OBEH.	7:18
30	62025	GÄNGSNITT	UNC				18:51
30	62026	GÄNGSNITT	UNF				18:51
30	60024	GÄNGSNITT, M, FINGÄNGA					18:50
30	62023	GÄNGSNITT, M, GROVGÄNGA	223				18:50
29	62040	GÄNGTAPP, FING. Nr. 2040			STÅL	HSS	
29	61041	GÄNGTAPP, M, BOTTEMHÅL					
29	61042	GÄNGTAPP, M, FING.	UNC	529	STÅL	HSS	18:34
29	61043	GÄNGTAPP, M, FING., BOTTENH.	UNF	529	STÅL	HSS	18:34
29	61040	GÄNGTAPP, M, GROVGÄNGA		529	STÅL	HSS	18:33
29	61070	GÄNGTAPP, VÄNSTER, Nr. 1040V		529	STÅL	HSS	18:35
29	61071	GÄNGTAPP, VÄNSTER, Nr. 1040V	UNC	529	STÅL	HSS	18:36
29	61072	GÄNGTAPP, VÄNSTER, Nr. 1040V	UNF	529	STÅL	HSS	18:36
30	8080	HB-TEKS, SEXKANT, BORRSPETS	7504K			FZB	8:6
30	8080	HB-TEKS, SEXKANT, BORRSPETS	7504K		A2		8:49
30	8081	HB-TEKS, SEXKANT, BORRSPETS	7504K			DURAL	8:6
17	11150	HCB, CYL. SKALLBULT m. HÅL	1434				11:7
18	11160	HCP, CYL. PINNE m. TVÅ HÅL	1443				11:13
1	3117	HLM6M, HELMET. LÅSMUTTER	6925		8	OBEH.	3:4
1	3118	HLM6M, HELMET. LÅSMUTTER	6925		8	FZB	3:4
1	3119	HLM6M, HELMET. LÅSMUTTER	6925		8	FZV	3:4
5	3120	HLM6M, HELMET. LÅSMUTTER	980	7042	8	OBEH.	3:4
5	3120	HLM6M, HELMET. LÅSMUTTER	980		A2		3:42
5	3121	HLM6M, HELMET. LÅSMUTTER	980	7042	8	FZB	3:4
5	3121	HLM6M, HELMET. LÅSMUTTER	980		A4		3:42
5	3122	HLM6M, HELMET. LÅSMUTTER	980	7042	8	FZV	3:4
5	3126	HLM6M, HELMET. LÅSMUTTER	980	7042	10	FZB	3:4
24	3248	HLM6MF, HELMET. FLÄNSLÅSMU	6927	7044	8	FZB	3:19
48	3701	HM, HJULMUTTER	74361A		8	FZB	3:22
49	3706	HMF, HJULMUTTER m. FLÄNS	74361B		8	FZB	3:22
49	3708	HMF, HJULMUTTER m. FLÄNS	74361B		10	FZB	3:22
2	4046	HRB, HÄRDAD BRICKA	6340			FZB	4:21
2	4245	HRB, HÄRDAD BRICKA	6340			OBEH.	4:21
1	4009	HRB, PLANBRICKA	125A	7089	HV300	OBEH.	4:1
1	4010	HRB, PLANBRICKA	125A	7089	HV300	FZB	4:1
27	10210	HS, HAMMARSKRUV	186		4.6	OBEH.	10:25
27	10210	HS, HAMMARSKRUV	186		A2		10:45
27	10211	HS, HAMMARSKRUV	186		4.6	FZB	10:25
27	10211	HS, HAMMARSKRUV	186		A4		10:45
15	1295	HSB, STÅLBYGGNADSBULT	6914	7412	10.9	OBEH.	1:44
15	1296	HSB, STÅLBYGGNADSBULT	6914	7412	10.9	FZB	1:45
15	1297	HSB, STÅLBYGGNADSBULT	6914	7412	10.9	FZV	1:46
8	4118	IB, I-BALKSBRICKA, 14%	6917			OBEH.	4:11
8	4119	IB, I-BALKSBRICKA, 14%	6917			FZV	4:11

SWEBOLT AB

TEL. 08-584 909 60 FAX. 08-583 581 82

BILD	ART.GR.	BENÄMNING	DIN	ISO	KVAL	YTBEH	SIDA
8	4123	IB, I-BALKSBRICKA, 14%	6918			OBEH.	4:11
8	4124	IB, I-BALKSBRICKA, 14%	6918			FZV	4:11
20	17060	IGA, INSATSG. f. PLAST, TYP A	16903A				16:8
22	17064	IGB, INSATSG. f. PLAST, TYP B	16903B				16:9
21	17062	IGC, INSATSG. f. PLAST, TYP C	16903C				16:8
3	11010	IGCP, INV. GÄNG CYL. PINNE m6	7979	8735			11:6
23	17066	IGD, INSATSG. f. PLAST, TYP D	16903D				16:9
24	17068	IGE, INSATSG. f. PLAST, TYP E	16903E				16:10
26	17072	IGF, INSATSG. f. PLAST, TYP F	16903F				16:11
25	17070	IGG, INSATSG. f. PLAST, TYP G	16903G				16:10
27	17074	IGH, INSATSG. f. PLAST, TYP H	16903H				16:11
5	11030	IGKP, KONISK, INV. GÄNGA h10	7978	8736			11:14
28	17076	IGP, INSATSG. f. PLAST, TYP P	16903P				16:12
30	17080	IGQ, INSATSG. f. PLAST, TYP Q	16903Q				16:13
29	17078	IGR, INSATSG. f. PLAST, TYP R	16903R				16:12
31	17082	IGS, INSATSG. f. PLAST, TYP S	16903S				16:13
8	17016	IM6S, TYP SK, INSATSM. m. INSEX	~7965SK			FZB	16:3
6	17012	IMS, TYP A, INSATSM. m. SPÅR	~7965A			FZB	16:2
7	17014	IMSF, TYP B, INV. FÖRSÄNK	~7965B			FZB	16:2
30	15700	INGJUTNINGSHYLSA				OBEH.	15:14
30	15700	INGJUTNINGSHYLSA			A2		15:14
30	15701	INGJUTNINGSHYLSA				FZB	15:14
31	15710	INGJUTNINGSHYLSA m. FLÄNS				OBEH.	15:14
31	15710	INGJUTNINGSHYLSA m. FLÄNS			A2		15:14
31	15711	INGJUTNINGSHYLSA m. FLÄNS				FZB	15:14
20	2200	INSEXSKRUV ESLOK + ÖVRIGA LÅSNINGAR				OBEH.	2:52
20	2201	INSEXSKRUV ÖVRIGA LÅSNINGAR				FZB	2:52
43	3520	IS, ISLAGSMUTTER				OBEH.	3:11
43	3521	IS, ISLAGSMUTTER				FZB	3:11
9	17018	ISM, TYP IS, ISLAGSMUTTER				FZB	16:3
5	5030	JV, LÅSRING U-TYP, AXEL				OBEH.	5:6
6	2070	K6S, KULLRIG INSEXSKRUV		7380	10.9	OBEH.	2:23
6	2070	K6S, KULLRIG INSEXSKRUV		7380	A2		2:71
6	2071	K6S, KULLRIG INSEXSKRUV		7380	10.9	FZB	2:24
6	2071	K6S, KULLRIG INSEXSKRUV		7380	A4		2:71
7	2072	K6SF, KULLRIG INSEX. m. FLÄNS			10.9	OBEH.	2:25
7	2073	K6SF, KULLRIG INSEX. m. FLÄNS			10.9	FZB	2:26
7	2072	K6SF, KULLRING INSEX m. FLÄNS			A2		2:72
28	15620	KARMSKRUV					15:13
14	14360	KAUSER	6899			FZB	14:8
14	14360	KAUSER	6899		A2		14:46
14	14361	KAUSER	6899			FZV	14:8
13	4150	KBA, KUPAD BRICKA	137A			OBEH.	4:6
13	4150	KBA, KUPAD BRICKA	137A		A2		4:41
13	4150	KBA, KUPAD BRICKA	137A				4:72
13	4151	KBA, KUPAD BRICKA	137A			FZB	4:6
13	4151	KBA, KUPAD BRICKA	137A		A4		4:41
13	4150	KBB, KUPAD BRICKA	137A				4:120
14	4155	KBB, KUPAD BRICKA	137B			OBEH.	4:6
14	4155	KBB, KUPAD BRICKA	137B		A2		4:48
14	4155	KBB, KUPAD BRICKA	137B				4:72
14	4156	KBB, KUPAD BRICKA	137B			FZB	4:6
14	4156	KBB, KUPAD BRICKA	137B		A4		4:48
7	13201	KBL-AL/AL, BRALO	ALU		ALU		13:3
7	13203	KBL-AL/RF, BRALO	ALU		ROSTFRI		13:4
7	13230	KBL-AL/ST, BEIGE	ALU		STÅL	1001	13:13
7	13200	KBL-AL/ST, BRALO	ALU		STÅL		13:1-2
7	13231	KBL-AL/ST, BRUN	ALU		STÅL	8014	13:13
7	13235	KBL-AL/ST, GRÖN	ALU		STÅL	6002	13:14
7	13223	KBL-AL/ST, GRÖNBLÅ	ALU		STÅL	5001	13:11

SWEBOLT AB

TEL. 08-584 909 60 FAX. 08-583 581 82

BILD	ART.GR.	BENÄMNING	DIN	ISO	KVAL	YTBEH	SIDA
7	13234	KBL-AL/ST, GULDGUL	ALU		STÅL	1004	13:14
7	13226	KBL-AL/ST, KLARRÖD	ALU		STÅL	3000	13:12
7	13229	KBL-AL/ST, LJUSBEIGE	ALU		STÅL	1015	13:13
7	13232	KBL-AL/ST, LJUSGRÅ	ALU		STÅL	7038	13:13
7	13224	KBL-AL/ST, MELLANBLÅ	ALU		STÅL	5007	13:11
7	13237	KBL-AL/ST, MOSSGRÖN	ALU		STÅL	6005	13:14
7	13228	KBL-AL/ST, MÖRKRÖD	ALU		STÅL	3007	13:12
7	13225	KBL-AL/ST, ORANGE	ALU		STÅL	2004	13:12
7	13233	KBL-AL/ST, RAPSGUL	ALU		STÅL	1021	13:14
7	13222	KBL-AL/ST, SVART	ALU		STÅL	5010	13:11
7	13227	KBL-AL/ST, VINRÖD	ALU		STÅL	3005	13:12
7	13221	KBL-AL/ST, VIT	ALU		STÅL	9010	13:11
7	13236	KBL-AL/ST, ÄRGGRÖN	ALU		STÅL	6021	13:14
13	13410	KBLBH-AL/ST	ALU		STÅL		13:47
8	13240	KBLEL-AL/ST	ALU		STÅL		13:34
8	13251	KBLEL-AL/ST, VIT	ALU		STÅL	9010	13:35
7	13206	KBL-KO/BR, BRALO	KOPPAR		BRONS		13:18
7	13205	KBL-KO/ST, BRALO	KOPPAR		STÅL		13:17
11	13386	KBLMG-AL/RF	ALU		ROSTFRI		13:36
11	13385	KBLMG-AL/ST	ALU		STÅL		13:36
7	13208	KBL-MO/RF, BRALO	MONEL		ROSTFRI		13:10
7	13207	KBL-MO/ST, BRALO	MONEL		STÅL		13:9
7	13204	KBL-RF/RF, BRALO	ROSTFRI		ROSTFRI		13:6
16	13330	KBLSM-AL/ST	ALU		STÅL		13:42
11	13332	KBLSMEL-AL/ST	ALU		STÅL		13:45
7	13202	KBL-ST/ST, BRALO	STÅL		STÅL		13:5
7	13260	KBLU-AL/ST	ALU		STÅL		13:37
7	13263	KBLU-AL/ST, VIT	ALU		STÅL	9010	13:40
7	13263	KBLU-KO/ST	KOPPAR		STÅL		13:38
7	13262	KBLU-ST/ST	STÅL		STÅL		13:39
6	13020	KDS, DRIVNIT			STÅL	FÖRNICK.	13:105
6	13020	KDS, DRIVNIT			A2		13:112
6	13021	KDS, DRIVNIT			A4		13:112
4	15301	KEMANKARE, HAC					15:2
4	15300	KEMANKARE, VDP					15:2
27	4220	KFB, FÖRSLUTNINGSBR. KONISK	443	A		OBEH.	4:16
27	4221	KFB, FÖRSLUTNINGSBR. KONISK	443	B		OBEH.	4:16
27	4216	KFB, FÖRSLUTNINGSBRICKA RAK443B			A2		4:50
5	13015	KFN, KULLERFÖRSÄNKT NIT	662		STÅL	OBEH.	13:104
5	13015	KFN, KULLERFÖRSÄNKT NIT	662				13:122
5	13015	KFN, KULLERFÖRSÄNKT NIT	662				13:132
5	13015	KFN, KULLERFÖRSÄNKT NIT	662				13:143
5	8009	KFSS, KULLERFÖRSÄNKT	7973C	1483C	A2		8:41
5	8010	KFSS, KULLERFÖRSÄNKT	7973C	1483C		FZB	8:4
5	8010	KFSS, KULLERFÖRSÄNKT	7973C	1483C	A4		8:42
29	8077	KFTB, KULLERFÖRSÄNKT, STAR	7504Q			FZB	8:14
17	8048	KFTS, KULLERFÖRSÄNKT, STAR	7983C	7051C	A2		8:45
17	8049	KFTS, KULLERFÖRSÄNKT, STAR	7983C	7051C		FZB	8:3
17	8049	KFTS, KULLERFÖRSÄNKT, STAR	7983C	7051C	A4		8:46
27	8075	KFXB, KULLERFÖRSÄNKT, PH	7504Q			FZB	8:13
28	8076	KFXB, KULLERFÖRSÄNKT, POZI	7504Q			FZB	8:13
15	8040	KFXS, KULLERFÖRSÄNKT, PH	7983C	7051C		FZB	8:1
15	8040	KFXS, KULLERFÖRSÄNKT, PH	7983C	7051C	A2		8:43
15	8042	KFXS, KULLERFÖRSÄNKT, PH	7983C	7051C	A4		8:44
16	8041	KFXS, KULLERFÖRSÄNKT, POZI	7983C	7051C		FZB	8:1
16	8041	KFXS, KULLERFÖRSÄNKT, POZI	7983C	7051C	A2		8:43
16	8043	KFXS, KULLERFÖRSÄNKT, POZI	7983C	7051C	A4		8:44
16	14400	KH, KARBINHAKE				OBEH.	14:10
16	14401	KH, KARBINHAKE				FZB	14:10

SWEBOLT AB

TEL. 08-584 909 60 FAX. 08-583 581 82

BILD	ART.GR.	BENÄMNING	DIN	ISO	KVAL	YTBEH	SIDA
60	4415	"KILLIBRODD", BULLDOGBRICKA, RUND				OBEH.	4:20
11	14300	KLAMMER	3570A			OBEH.	14:5
11	14300	KLAMMER			A2		14:43
11	14301	KLAMMER	3570A			FZB	14:5
11	14301	KLAMMER			A4		14:44
11	14302	KLAMMER				OBEH.	14:6
11	14303	KLAMMER				FZB	14:6
11	14304	KLAMMER				FZV	14:6
16	5085	KLB, KLÄMBRICKA, AXEL				OBEH.	5:5
16	5086	KLB, KLÄMBRICKA, AXEL				FZB	5:5
5	10025	KLÄMSKRUV				OBEH.	10:13
5	10026	KLÄMSKRUV				FZB	10:13
47	3280	KM, KULLAGERLÅSMUTTER	1804			OBEH.	3:29
1	13000	KN, KULLRIG NIT	660		STÅL	OBEH.	13:100
1	13000	KN, KULLRIG NIT	660		A2		13:110
1	13000	KN, KULLRIG NIT	660				13:120
1	13000	KN, KULLRIG NIT	660				13:130
1	13000	KN, KULLRIG NIT	660				13:140
2	13001	KNH, KULLRIG NIT, HALVRUND	674		STÅL	OBEH.	13:102
2	13001	KNL, KULLRIG NIT, LÅG	674				13:141
3	13002	KNL, KULLRIG NIT, LÅG	124		STÅL	OBEH.	13:102
32	13040	KNR, KULLRIG NIT, RÄFFLAD	1476	8746			
31		KNR, RÄFFLAD KULLRIG NIT	1476		STÅL		13:106
42	3601	KOM, KORGMUTTER				A2/FZB	3:26
21	3401	KOMBIMUTTER (mutter+bricka)				FZB	3:22
22	14440	KOMP. KULLED	71802A				14:12
24	14442	KOMP. KULLED FÖR NITNING	71802BS				14:12
23	14441	KOMP. KULLED MED GÄNGA	71802CS				14:12
4	11020	KP, KONISK PINNE	1	2339	STÅL		11:4
4	11020	KP, KONISK PINNE	1	2339	A2		11:44
4	11021	KP, KONISK PINNE	1	2339	STÅL	HÄRDAD	11:5
4	11021	KP, KONISK PINNE	1	2339	A4		11:44
18	2190	KTS, KULLRIG STAR		~7380	10.9	OBEH.	2:37
18	2191	KTS, KULLRIG STAR		~7380	10.9	FZB	2:37
19	2195	KTSF, KULLRIG STAR m. FLÄNS			10.9	OBEH.	2:38
19	2196	KTSF, KULLRIG STAR m. FLÄNS			10.9	FZB	2:38
9	12120	KULA	5401				12:6
9	12120	KULA	5401		A2		12:43
17	14420	KULLEDSHÅLLARE	71805A				14:11
18	14421	KULLEDSHÅLLARE	71805B				14:11
20	14350	KULTAPP MED GÄNGA	71803C				14:11
21	14351	KULTAPP UTAN GÄNGA FÖR NITNING	71803B				14:11
22	4190	LB1, LÅSBLECK m. 1 LÄPP	93			OBEH.	4:14
22	4190	LB1, LÅSBLECK m. 1 LÄPP	93		A2		4:42
22	4191	LB1, LÅSBLECK m. 1 LÄPP	93			FZB	4:14
22	4191	LB1, LÅSBLECK m. 1 LÄPP	93		A4		4:42
23	4195	LB2, LÅSBLECK m. 2 LÄPPAR	463			OBEH.	4:14
23	4196	LB2, LÅSBLECK m. 2 LÄPPAR	463			FZB	4:14
23	4196	LB2, LÅSBRICKA 2-LÄPP	463		A4		4:42
21	4185	LB4, REKTANGULÄRT LÅSBLECK				OBEH.	4:14
21	4186	LB4, REKTANGULÄRT LÅSBLECK				FZB	4:14
15	4160	LB-AT, LÅSBRICKA GROVT. AT.	6797A			OBEH.	4:13
15	4161	LB-AT, LÅSBRICKA GROVT. AT.	6797A			FZB	4:13
15	4160	LB-AT, LÅSBRICKA, GROVT. AT.	6797A		A2		4:49
15	4161	LB-AT, LÅSBRICKA, GROVT. AT.	6797A		A4		4:49
17	4170	LB-AZ, LÅSBRICKA	6798A		A2		4:41
17	4170	LB-AZ, LÅSBRICKA	6798A				4:121
17	4171	LB-AZ, LÅSBRICKA	6798A		A4		4:41
17	4170	LB-AZ, LÅSBRICKA FINT. AZ	6798A			OBEH.	4:6

SWEBOLT AB

TEL. 08-584 909 60 FAX. 08-583 581 82

BILD	ART.GR.	BENÄMNING	DIN	ISO	KVAL	YTBEH	SIDA
17	4171	LB-AZ, LÅSBRICKA FINT. AZ	6798A			FZB	4:6
26	4210	LBFL, FLERLÄPPS LÅSBLECK	70952A			OBEH.	4:15
26	4211	LBFL, FLERLÄPPS LÅSBLECK	70952A			FZB	4:15
25	4205	LBIL, LÅSBLECK INV. LÄPP	462			OBEH.	4:15
25	4206	LBIL, LÅSBLECK INV. LÄPP	462			FZB	4:15
16	4162	LB-IT, LÅSBRICKA	6797I		A2		4:49
16	4163	LB-IT, LÅSBRICKA	6797I		A4		4:49
16	4162	LB-IT, LÅSBRICKA GROVT. IT.	6797I			OBEH.	4:13
16	4163	LB-IT, LÅSBRICKA GROVT. IT.	6797I			FZB	4:13
18	4172	LB-IZ, LÅSBRICKA	6798J		A2		4:41
18	4172	LB-IZ, LÅSBRICKA	6798J				4:121
18	4173	LB-IZ, LÅSBRICKA	6798J		A4		4:41
18	4172	LB-IZ, LÅSBRICKA FINT. IZ	6798J			OBEH.	4:6
18	4173	LB-IZ, LÅSBRICKA FINT. IZ	6798J			FZB	4:6
19	4174	LB-IZV, FÖRSÄNKT LÅSBRICKA	6798V			OBEH.	4:13
19	4174	LB-IZV, FÖRSÄNKT LÅSBRICKA	6798V		A2		4:49
19	4175	LB-IZV, FÖRSÄNKT LÅSBRICKA	6798V			FZB	4:13
19	4175	LB-IZV, FÖRSÄNKT LÅSBRICKA	6798V		A4		4:49
24	4200	LBUL, LÅSBLECK UTV. LÄPP	432			OBEH.	4:14
24	4200	LBUL, LÅSBLECK UTV. LÄPP	432		A2		4:42
24	4201	LBUL, LÅSBLECK UTV. LÄPP	432			FZB	4:14
24	4201	LBUL, LÅSBLECK UTV. LÄPP	432		A4		4:42
24	10170	LETTERSKRUV	653		5.8	OBEH.	10:6
24	10170	LETTERSKRUV	653				10:62
24	10171	LETTERSKRUV	653		5.8	FZB	10:6
25	10180	LETTERSKRUV m. ANSATS	464		5.8	OBEH.	10:6
25	10181	LETTERSKRUV m. ANSATS	464		5.8	FZB	10:6
18	10110	LH, LYFTÖGLA, HÅL	582		C15	OBEH.	10:4
18	10110	LH, LYFTÖGLA, HÅL	582		A2		10:43
18	10111	LH, LYFTÖGLA, HÅL	582		C15	FZB	10:4
18	10111	LH, LYFTÖGLA, HÅL	582		A4		10:43
18	10112	LH, LYFTÖGLA, HÅL	582		C15	FZV	10:4
18	10115	LH, LYFTÖGLA, HÅL, UNC	582		C15	OBEH.	10:26
18	10116	LH, LYFTÖGLA, HÅL, UNC	582		C15	FZB	10:26
18	10117	LH, LYFTÖGLA, HÅL, UNC	582		C15	FZV	10:26
25	7260	LITEN SKALLE + TAPP	922			OBEH.	7:18
5	7041	LKCS, KULLRIG STOR SKALLE			A2		7:50
5	7040	LKCS, STOR LÅG KULLERSK.					7:81
5	7041	LKCS, STOR LÅG KULLERSKALLE			4.6	FZB	7:12
5	7041	LKCS, STOR LÅG KULLERSKALLE				FÖRNICKLAD	7:64
47	3285	LKM, KULLAGERLÅSMUTTER m. NYLONRING					3:30
31	3280	LM, LÅSMUTTER FÖR AXEL				OBEH.	3:27
31	3281	LM, LÅSMUTTER FÖR AXEL				FZB	3:27
3	3100	LM6M, NYLONLÅSMUTTER	985		6-8	FZB	3:3
3	3100	LM6M, NYLONLÅSMUTTER	985		A2		3:40
3	3100	LM6M, NYLONLÅSMUTTER	985			OBEH.	3:52
3	3101	LM6M, NYLONLÅSMUTTER	985		10	FZB	3:3
3	3101	LM6M, NYLONLÅSMUTTER	985		A4-80		3:40
3	3101	LM6M, NYLONLÅSMUTTER	985			FÖRNICKLAD	3:52
3	3102	LM6M, NYLONLÅSMUTTER	985		A2	FZB	3:43
3	3103	LM6M, NYLONLÅSMUTTER	985		A4	FZB	3:43
23	3245	LM6MF, FLÄNSLÅSMUTTER	6926	7073	8	FZB	3:9
4	3108	LM6MH, HÖG LÅSMUTTER	6924	7040	8	FZB	3:3
4	3109	LM6MH, HÖG LÅSMUTTER	6924	7040	10	FZB	3:3
4	3103	LM6MH, NYLONLÅSM, HÖG	982		A2		3:44
4	3104	LM6MH, NYLONLÅSM, HÖG	982		A4		3:44
4	3103	LM6MH, NYLONLÅSMU., HÖG	982		8	FZB	3:3
4	3104	LM6MH, NYLONLÅSMU., HÖG	982		10	FZB	3:3

SWEBOLT AB

TEL. 08-584 909 60 FAX. 08-583 581 82

BILD	ART.GR.	BENÄMNING	DIN	ISO	KVAL	YTBEH	SIDA
11	3190	LMHM, HATTM. m. NYLONLÅSR.	986			OBEH.	3:21
11	3191	LMHM, HATTM. m. NYLONLÅSR.	986			FZB	3:21
2	14010	LN, LÅSNÅL	11024			FZB	14:2
2	14010	LN, LÅSNÅL	11024		A4		14:43
4	14012	LNN, BRUTEN NACKE				FZB	14:2
21	7220	LP, LÅSPINNE m. SPÅR	427	2342		OBEH.	7:17
21	7221	LP, LÅSPINNE m. SPÅR	427	2342		FZB	7:17
7	12100	LR, LÅSRING					12:5
8	12110	LR, LÅSRING, DUBBEL					12:5
27	3260	LRM, LÅG R. LÄTTRAD MUTTER	467			OBEH.	3:55
27	3261	LRM, LÅG R. LÄTTRAD MUTTER	467			FÖRNICKLAD	3:55
27	3260	LRM, LÅG RUND LÄTTRAD MU.	467			OBEH.	3:23
27	3260	LRM, LÅG RUND LÄTTRAD MU.	467		A1		3:45
27	3260	LRM, LÅG RUND LÄTTRAD MU.	467				3:91
27	3261	LRM, LÅG RUND LÄTTRAD MU.	467			FZB	3:23
27	3261	LRM, LÅG RUND LÄTTRAD MU.	467		A4		3:45
10	15260	LS, LISTSKRUV				FZB	15:4
5	14030	LS, LÅSSPRINT, (TRAKTORS- SPRINT)				FZB	14:2
26	10200	LS, LÄNKSKRUV	444 A,B,C		4.6	OBEH.	10:22
26	10200	LS, LÄNKSKRUV	444 B		A2		10:45
26	10201	LS, LÄNKSKRUV	444 A,B,C		4.6	FZB	10:22
26	10201	LS, LÄNKSKRUV	444 B		A4		10:45
26	10203	LS, LÄNKSKRUV	444 A,B,C		8.8	OBEH.	10:23
26	10204	LS, LÄNKSKRUV	444 A,B,C		8.8	FZB	10:23
26	10206	LS, LÄNKSKRUV	SMS			OBEH.	10:24
26	10207	LS, LÄNKSKRUV	SMS			FZB	10:24
9	9040	LSS, LEDSTÅNGSSKRUV				OBEH.	9:10
9	9041	LSS, LEDSTÅNGSSKRUV				FZB	9:10
17	10100	LT, LYFTÖGLA, TAPP	580	3266	C15	OBEH.	10:4
17	10100	LT, LYFTÖGLA, TAPP	580		A2		10:43
17	10101	LT, LYFTÖGLA, TAPP	580	3266	C15	FZB	10:4
17	10101	LT, LYFTÖGLA, TAPP	580		A4		10:43
17	10102	LT, LYFTÖGLA, TAPP	580	3266	C15	FZV	10:4
17	10105	LT, LYFTÖGLA, TAPP, UNC	580	3266	C15	OBEH.	10:26
17	10106	LT, LYFTÖGLA, TAPP, UNC	580	3266	C15	FZB	10:26
17	10107	LT, LYFTÖGLA, TAPP, UNC	580	3266	C15	FZV	10:26
11	5065	LTU, LÅSTRÅD U, AXEL				OBEH.	5:8
11	5066	LTU, LÅSTRÅD U, AXEL				FZB	5:8
3	3105	LU6M, NYLONLÅSMUTTER	UNC		8	FZB	3:31
4	3110	LU6MH, HÖG LÅSMUTTER	UNC		8	FZB	3:31
19	14430	LÅSFJÄDER FÖR KULLED					14:11
45	8340	LÅSSKRUV, CYL. SKALLE m. 2 HÅL				FZB	8:17
45	8340	LÅSSKRUV, CYL. SKALLE m. 2 HÅL			A2		8:50
46	8343	LÅSSKRUV, FÖRSÄNKT SKALLE m. 2 HÅL				FZB	8:17
46	8343	LÅSSKRUV, FÖRSÄNKT SKALLE m. 2 HÅL			A2		8:50
39	10440	M3S, TREKANTSSKRUV				OBEH.	10:34
16	3220	M4M, 4-KANTMUTTER	557		A2		3:45
16	3221	M4M, 4-KANTMUTTER	557		A4		3:45
16	3220	M4M, FYRKANTMUTTER	557			OBEH.	3:10
16	3221	M4M, FYRKANTMUTTER	557			FZB	3:10
1	3001	M6M, SEXKANTMUTTER	555	4034	6	OBEH.	3:17
1	3001	M6M, SEXKANTMUTTER	555	4034			3:90
1	3002	M6M, SEXKANTMUTTER	555	4034	6	FZB	3:17
1	3003	M6M, SEXKANTMUTTER	555	4034	6	FZV	3:17
1	3010	M6M, SEXKANTMUTTER	934		A2		3:40
1	3010	M6M, SEXKANTMUTTER	934				3:90
1	3010	M6M, SEXKANTMUTTER	934				3:70
1	3010	M6M, SEXKANTMUTTER	934				3:80
1	3011	M6M, SEXKANTMUTTER	934		A4-80		3:40

SWEBOLT AB

TEL. 08-584 909 60 FAX. 08-583 581 82

BILD	ART.GR.	BENÄMNING	DIN	ISO	KVAL	YTBEH	SIDA
1	3012	M6M, SEXKANTMUTTER		4032	A2		3:43
1	3013	M6M, SEXKANTMUTTER		4032	A4-80		3:43
1	3016	M6M, SEXKANTMUTTER	934	4032	A2	FZB	3:43
1	3017	M6M, SEXKANTMUTTER	934	4032	A4-80	FZB	3:43
1	3010	M6M, SEXKANTMUTTER 0,8d	934		8	OBEH.	3:1
1	3010	M6M, SEXKANTMUTTER 0,8d	934			OBEH.	3:51
1	3010	M6M, SEXKANTMUTTER 0,8d	934				3:95
1	3011	M6M, SEXKANTMUTTER 0,8d	934		8	FZB	3:1
1	3011	M6M, SEXKANTMUTTER 0,8d	934			FÖRNICKLAD	3:51
1	3012	M6M, SEXKANTMUTTER 0,8d	934		8	FZV	3:1
1	3016	M6M, SEXKANTMUTTER 0,8d	934		10	OBEH.	3:2
1	3017	M6M, SEXKANTMUTTER 0,8d	934		10	FZB	3:2
1	3020	M6M, SEXKANTMUTTER 0,8d	934		12	OBEH.	3:2
1	3013	M6M, SEXKANTMUTTER 0,9d	970	4032	8	OBEH.	3:1
1	3014	M6M, SEXKANTMUTTER 0,9d	970	4032	8	FZB	3:1
1	3015	M6M, SEXKANTMUTTER 0,9d	970	4032	8	FZV	3:1
1	3018	M6M, SEXKANTMUTTER 0,9d	970	4032	10	OBEH.	3:2
1	3019	M6M, SEXKANTMUTTER 0,9d	970	4032	10	FZB	3:2
1	3021	M6M, SEXKANTMUTTER 0,9d	970	4032	12	OBEH.	3:2
1	3043	M6M, SEXKANTMUTTER 1,0d		4033	8	OBEH.	3:17
1	3043	M6M, SEXKANTMUTTER 1,0d		4033		OBEH.	3:53
1	3044	M6M, SEXKANTMUTTER 1,0d		4033	8	FZB	3:17
1	3044	M6M, SEXKANTMUTTER 1,0d		4033		FÖRNICKLAD	3:53
1	3045	M6M, SEXKANTMUTTER 1,0d		4033	10	OBEH.	3:17
1	3046	M6M, SEXKANTMUTTER 1,0d		4033	10	FZB	3:17
1	3047	M6M, SEXKANTMUTTER 1,0d		4033	12	OBEH.	3:17
7	6135	M6M2H, VARMHÅLLF. MUTTER	934	ASTM.A 194 Gr 2H		OBEH.	6:5
21	3241	M6MF, FLÄNSMUTTER	6923	4161	8	FZB	3:9
21	3242	M6MF, FLÄNSMUTTER	6923	4161	10	FZB	3:9
22	3296	M6MFT, TENSILOCK	~6923		8	FZB	3:9
18	3232	M6MH, SKARVMUTTER 1,5 x D	6330		A2		3:48
19	3232	M6MH, SKARVMUTTER 1,5 x D	6330		8-10	OBEH.	3:12
18	3233	M6MH, SKARVMUTTER 1,5 x D	6330		A4		3:48
19	3233	M6MH, SKARVMUTTER 1,5 x D	6330		8-10	FZB	3:12
18	3236	M6MH, SKARVMUTTER 3 x D	6334		8-10	OBEH.	3:12
18	3236	M6MH, SKARVMUTTER 3 x D	6334		A2		3:48
18	3236	M6MH, SKARVMUTTER 3 x D	6334			OBEH.	3:55
18	3237	M6MH, SKARVMUTTER 3 x D	6334		8-10	FZB	3:12
18	3230	M6MH, SKARVMUTTER 6-KANT				OBEH.	3:12
18	3231	M6MH, SKARVMUTTER 6-KANT				FZB	3:12
18	3232	M6MH, SKARVMUTTER 6-KANT				FZV	3:12
18	3230	M6MH, SKARVMUTTER, 6-KANT			A2		3:48
18	3231	M6MH, SKARVMUTTER, 6-KANT			A4		3:48
20	3234	M6MHF, 1,5 x D m. FLÄNS	6331		8-10	OBEH.	3:12
20	3234	M6MHF, 1,5 x D m. FLÄNS	6331		A2		3:48
20	3235	M6MHF, 1,5 x D m. FLÄNS	6331		8-10	FZB	3:12
20	3235	M6MHF, 1,5 x D m. FLÄNS	6331		A4		3:48
1	3040	M6MSB, STÅLBYGGN.MUTTER	6915	7414	10	OBEH.	3:6
1	3041	M6MSB, STÅLBYGGN.MUTTER	6915	7414	10	FZB	3:6
1	3042	M6MSB, STÅLBYGGN.MUTTER	6915	7414	10	FZV	3:6
13	1301	M6S - DRYLOC YTBHANDLING ENL ÖNSKEMÅL					1:66
13	1302	M6S - DRYSEAL YTBHANDLING ENL ÖNSKEMÅL					1:66
13	1300	M6S - ESLOK YTBHANDLING ENL ÖNSKEMÅL					1:66
13	1303	M6S - PRICOTE 5 YTBHANDLING ENL ÖNSKEMÅL					1:66
2	1106	M6S, 6-KANT, DELG.	601	4016	4.6-6.8	FZB	1:41
2	1107	M6S, 6-KANT, DELG.	601	4016	4.6	FZV	1:42
4	1110	M6S, 6-KANT, DELG.		4014	8.8	OBEH.	1:3-4
4	1110	M6S, 6-KANT, DELG.	931	4014			1:81
4	1110	M6S, 6-KANT, DELG.	931	4014			1:87
4	1111	M6S, 6-KANT, DELG.		4014	8.8	FZB	1:7-8

SWEBOLT AB

TEL. 08-584 909 60 FAX. 08-583 581 82

BILD	ART.GR.	BENÄMNING	DIN	ISO	KVAL	YTBEH	SIDA
4	1111	M6S, 6-KANT, DELG.	931	4014		FÖRNICKLAD	1:82
4	1112	M6S, 6-KANT, DELG.		4014	8.8	FZV	1:10
4	1113	M6S, 6-KANT, DELG.	931		8.8	OBEH.	1:3-4
4	1114	M6S, 6-KANT, DELG.	931		8.8	FZB	1:7-8
4	1115	M6S, 6-KANT, DELG.	931		8.8	FZV	1:10
4	1130	M6S, 6-KANT, DELG.		4014	10.9	OBEH.	1:13-14
4	1131	M6S, 6-KANT, DELG.		4014	10.9	FZB	1:17-18
4	1134	M6S, 6-KANT, DELG.	931		10.9	OBEH.	1:13-14
4	1135	M6S, 6-KANT, DELG.	931		10.9	FZB	17:18
4	1137	M6S, 6-KANT, DELG.		4014	12.9	OBEH.	1:20
4	1139	M6S, 6-KANT, DELG.	931		12.9	OBEH.	1:20
2	1105	M6S, 6-KANT, HELG.	601	4016	4.6-6.8	OBEH.	1:40
4	1110	M6S, ROSTFRI, DELG.		4014	A2		1:72
4	1113	M6S, ROSTFRI, DELG.	931		A2		1:72
4	1131	M6S, ROSTFRI, DELG.	931	4014	A2	FZB	1:84
4	1111	M6S, SYRAFAST, DELG.		4014	A4		1:76
4	1112	M6S, SYRAFAST, DELG.		4014	A4-80		1:74
4	1114	M6S, SYRAFAST, DELG.	931		A4		1:76
4	1115	M6S, SYRAFAST, DELG.	931		A4-80		1:74
4	1133	M6S, SYRAFAST, DELG.	931	4014	A4-80	FZB	1:86
7	1191	M6SBBL, K6, KORT GÄNGA	610		8.8	OBEH.	1:58
5	1170	M6SF, 6-KANT MED FLÄNS	6921		8.8	OBEH.	1:31
5	1171	M6SF, 6-KANT MED FLÄNS	6921		8.8	FZB	1:32
5	1172	M6SF, 6-KANT MED FLÄNS	6921		10.9	OBEH.	1:33
5	1173	M6SF, 6-KANT MED FLÄNS	6921		10.9	FZB	1:34
5	1176	M6SFE, 6-KANT M FLÄNS			A2		1:79
6	1180	M6SFT, RÄFFLAD 6-KANTSKRUV			8.8	OBEH.	1:37
6	1181	M6SFT, RÄFFLAD 6-KANTSKRUV			8.8	FZB	1:38
32	8200	M6SF-TT, SEXKANT, TAPTITE	7500D		A2		8:48
32	8200	M6SF-TT, TAPTITE, SEXKANT	7500D			FZB	8:8
53	8381	M6S-GS, 6-KANT, GÄNGSKÄRANDE			HV450	FZB	8:21
3	1110	M6SH, 6-KANT, HELG.		4017	8.8	OBEH.	1:1-2
3	1110	M6SH, 6-KANT, HELG.	933	4017			1:81
3	1110	M6SH, 6-KANT, HELG.	933	4017			1:87
3	1110	M6SH, 6-KANT, HELG.	933	4017			1:85
3	1110	M6SH, 6-KANT, HELG.	933	4017			1:86
3	1110	M6SH, 6-KANT, HELG.	933	4017			1:88
3	1111	M6SH, 6-KANT, HELG.		4017	8.8	FZB	1:5-6
3	1111	M6SH, 6-KANT, HELG.	933	4017		FÖRNICKLAD	1:82
3	1112	M6SH, 6-KANT, HELG.		4017	8.8	FZV	1:9
3	1113	M6SH, 6-KANT, HELG.	933		8.8	OBEH.	1:1-2
3	1114	M6SH, 6-KANT, HELG.	933		8.8	FZB	1:5-6
3	1115	M6SH, 6-KANT, HELG.	933		8.8	FZV	1:9
3	1136	M6SH, 6-KANT, HELG.		4017	12.9	OBEH.	1:19
3	1138	M6SH, 6-KANT, HELG.	933		12.9	OBEH.	1:19
1	1101	M6SH, 6-KANT, HELG.	558	4018	5.8	OBEH.	1:39
1	1102	M6SH, 6-KANT, HELG.	558	4018	5.8	FZB	1:39
3	1110	M6SH, ROSTFRI, HELG.		4017	A2		1:71
3	1113	M6SH, ROSTFRI, HELG.	933		A2		1:71
3	1130	M6SH, ROSTFRI, HELG.	933	4017	A2	FZB	1:83
3	1111	M6SH, SYRAFAST, HELG.		4017	A4		1:75
3	1112	M6SH, SYRAFAST, HELG.		4017	A4-80		1:73
3	1114	M6SH, SYRAFAST, HELG.	933		A4		1:75
3	1115	M6SH, SYRAFAST, HELG.	933		A4-80		1:73
3	1132	M6SH, SYRAFAST, HELG.	933	4017	A4-80	FZB	1:85
3	1130	M6SH, 6-KANT, HELG.		4017	10.9	OBEH.	1:11-12
3	1131	M6SH, 6-KANT, HELG.		4017	10.9	FZB	1:15-16
9	1250	M6SHSZ, 6-KANT+MEJSELSPÅR	933SZ		5.8	OBEH.	1:51
9	1250	M6SHSZ, 6-KANT+MEJSELSPÅR	933SZ				1:83
9	1251	M6SHSZ, 6-KANT+MEJSELSPÅR	933SZ		5.8	FZB	1:51

SWEBOLT AB

TEL. 08-584 909 60 FAX. 08-583 581 82

BILD	ART.GR.	BENÄMNING	DIN	ISO	KVAL	YTBEH	SIDA
12	1290	M6SOB, 6-KANT + BRICKA	6900				1:54
12	1290	M6SOB, 6-KANT + BRICKA	6900		A4		1:80
6	1200	M6SPB, 6-KANT, PASSNING h11	7968		5.6	OBEH.	1:47
7	1190	M6SPBK, K6, LÅNG GÄNGA	609		8.8	OBEH.	1:57
40	8300	M6SSG, GÄNGSKÄRANDE 6-KANT	7513A			OBEH.	8:15
40	8301	M6SSG, GÄNGSKÄRANDE 6-KANT	7513A			FZB	8:15
11	1266	M6ST, TAPP	564B		8.8	OBEH.	1:53
11	1267	M6ST, TAPP	564B		8.8	FZB	1:53
10	1260	M6STG, TAPP OCH GÄNGA	561A		8.8	OBEH.	1:52
10	1261	M6STG, TAPP OCH GÄNGA	561A		8.8	FZB	1:52
32	8207	M6S-TT, TAPTITE UTAN FLÄNS	7500D			FZB	8:8
9	68300	MAGNETHYLSA					18:5
6	68100	MASKINSKRUVMEJSEL, PH, PHILIPS		SEGHÄRDAD		SVART	18:3
6	68110	MASKINSKRUVMEJSEL, PH, PHILIPS		EXTRA HÅRD		GRÅ	18:3
7	68130	MASKINSKRUVMEJSEL, POZI		SEGHÄRDAD		SVART	18:3
7	68140	MASKINSKRUVMEJSEL, POZI		EXTRA HÅRD		GRÅ	18:3
8	68150	MASKINSKRUVMEJSEL, STAR		SEGHÄRDAD		SVART	18:4
8	68160	MASKINSKRUVMEJSEL, STAR		EXTRA HÅRD		GRÅ	18:4
36	4300	MB, LÅSBRICKA FÖR KULLAGER				OBEH.	4:19
36	4301	MB, LÅSBRICKA FÖR KULLAGER				FZB	4:19
1-2	2000	MC6S, INSEXSKRUV	912	4762	8.8	OBEH.	2:1-2
1-2	2000	MC6S, INSEXSKRUV	912	4762	A2		2:61
1-2	2000	MC6S, INSEXSKRUV	912	4762			2:84
1-2	2001	MC6S, INSEXSKRUV	912	4762	8.8	FZB	2:3-4
1-2	2001	MC6S, INSEXSKRUV	912	4762	A4		2:64
1-2	2002	MC6S, INSEXSKRUV	912	4762	8.8	DACROMET	2:7
1-2	2005	MC6S, INSEXSKRUV	912	4762	12.9	OBEH.	2:5-6
1-2	2005	MC6S, INSEXSKRUV	912	4762	A4-80		2:62
1-2	2007	MC6S, INSEXSKRUV	912	4762	10.9	OBEH.	2:10
1-2	2008	MC6S, INSEXSKRUV	912	4762	10.9	FZB	2:11
1-2	2009	MC6S, INSEXSKRUV	912	4762	10.9	DACROMET	2:11
1-2	2014	MC6S, INSEXSKRUV	912	4762	A2	FÖRZINKAD	2:65
1-2	2015	MC6S, INSEXSKRUV	912	4762	A4-80	FÖRZINKAD	2:66
25	2220	MC6SB, INSEX m. BRICKA	6900		A2		2:77
17	2180	MC6SF, INSEXSKRUV m. FLÄNS			12.9	OBEH.	2:35
17	2181	MC6SF, INSEXSKRUV m. FLÄNS			12.9	FZB	2:35
17	2175	MC6SFT, INSEXSKRUV m. TENSI.			100	OBEH.	2:36
2	2003	MC6SH, HELGÄNGA	912	4762	A2		2:63
2	2004	MC6SH, HELGÄNGA	912	4762	A4		2:63
2	2003	MC6SH, INSEXSKRUV, HELG	912	4762	8.8	OBEH.	2:8
2	2004	MC6SH, INSEXSKRUV, HELG.	912	4762	8.8	FZB	2:8
2	2006	MC6SH, INSEXSKRUV, HELG.	912	4762	12.9	OBEH.	2:12
15	2160	MC6SPB, PASSBULT		7379	12.9	OBEH.	2:33
15	2160	MC6SPB, PASSBULT		~7379	A2		2:75
33	8201	MC6S-TT, TAPTITE, INSEX	7500E			FZB	8:8
1	7004	MCLS, LITEN CYL. SKALLE			4.8	FZB	7:2
12	7130	MCS Z1, OFÖRLORBAR BR.	84 Z1/6902A		4.8	FZB	7:16
13	7140	MCS Z4, OFÖRLORBAR LÅSBR.	84 Z4/6905		4.8	FZB	7:16
1	7000	MCS, CYL. SKALLE	84	1207	4.8	OBEH.	7:1
1	7000	MCS, CYL. SKALLE	84	1207	A2		7:41
1	7000	MCS, CYL. SKALLE	84	1207			7:60
1	7000	MCS, CYL. SKALLE	84	1207			7:80
1	7000	MCS, CYL. SKALLE	84	1207			7:70
1	7001	MCS, CYL. SKALLE	84	1207	4.8	FZB	7:1
1	7001	MCS, CYL. SKALLE	84	1207	A4		7:41
1	7001	MCS, CYL. SKALLE	84	1207		FÖRNICKLAD	7:60
1	7003	MCS, CYL. SKALLE	84	1207	8.8	FZB	7:2
52	8376	MCS-GS, KULLRIG, GÄNGSKÄRANDE			HV450	FZB	8:20
24	7046	MCSL, LITEN SKALLE			4.8	FZB	7:6

SWEBOLT AB

TEL. 08-584 909 60 FAX. 08-583 581 82

BILD	ART.GR.	BENÄMNING	DIN	ISO	KVAL	YTBEH	SIDA
41	8310	MCSSG, GÄNGSKÄRANDE, KULL.	7513B			OBEH.	8:15
41	8311	MCSSG, GÄNGSKÄRANDE, KULL.	7513B			FZB	8:15
3	2031	MF6S, FÖRSÄNKAT INSEXSKRUV	7991		A4		2:68
3	2030	MF6S, FÖRSÄNKAT INSEXSKRUV	7991		8.8	OBEH.	2:15
3	2030	MF6S, FÖRSÄNKAT INSEXSKRUV	7991		A2		2:67
3	2031	MF6S, FÖRSÄNKAT INSEXSKRUV	7991		10.9	OBEH.	2:13
3	2032	MF6S, FÖRSÄNKAT INSEXSKRUV	7991		10.9	FZB	2:14
3	2033	MF6S, FÖRSÄNKAT INSEXSKRUV	7991		8.8	FZB	2:16
2	7018	MFLS, LITEN FÖRSÄNKAT				FZB	7:15
2	7018	MFLS, FÖRSÄNKAT, LITEN SKALLE			A2		7:57
41	3330	MFM, FÖRSÄNKAT MUTTER 110°				OBEH.	3:24
41	3331	MFM, FÖRSÄNKAT MUTTER 110°				FZB	3:24
2	7010	MFS, FÖRSÄNKAT	963	2009	A2		7:42
2	7010	MFS, FÖRSÄNKAT	963	2009			7:61
2	7010	MFS, FÖRSÄNKAT	963	2009			7:80
2	7010	MFS, FÖRSÄNKAT	963	2009			7:71
2	7011	MFS, FÖRSÄNKAT	963	2009	4.8	FZB	7:3
2	7011	MFS, FÖRSÄNKAT	963	2009	A4		7:42
2	7011	MFS, FÖRSÄNKAT	963	2009		FÖRNICKLAD	7:61
2	7013	MFS, FÖRSÄNKAT	963	2009	8.8	FZB	7:4
2	7010	MFS, FÖRSÄNKAT	963	2009	4.8	OBEH.	7:3
51	8371	MFS-GS, FÖRSÄNKAT, GÄNGSKÄRANDE			HV450	FZB	8:20
8	10046	MFSS, FÖRSÄNKAT, MEJSELSPÅR	7969		4.6	OBEH.	10:14
8	10047	MFSS, FÖRSÄNKAT, MEJSELSPÅR	7969		4.6	FZB	10:14
42	8320	MFSSG, GÄNGSKÄRANDE, FÖRS.	7513F			OBEH.	8:16
42	8321	MFSSG, GÄNGSKÄRANDE, FÖRS.	7513F			FZB	8:16
29	7082	MFT, FÖRSÄNKAT, STAR	~965	~7046	4.8	OBEH.	7:13
29	7082	MFT, FÖRSÄNKAT, STAR	~965	~7046	A2		7:48
29	7083	MFT, FÖRSÄNKAT, STAR	~965	~7046	4.8	FZB	7:13
29	7083	MFT, FÖRSÄNKAT, STAR	~965	~7046	A4		7:48
29	7084	MFT, FÖRSÄNKAT, STAR	~965	~7046	8.8	FZB	7:13
38	8240	MFTF-TT, FLAKSKRUV, STAR				FZB	8:10
23	2215	MFTS, FÖRS. INSEXS. m. STAR	~7991		8.8	OBEH.	2:40
23	2216	MFTS, FÖRS. INSEXS. m. STAR	~7991		8.8	FZB	2:40
36	8216	MFT-TT, TAPTITE, FÖRS., STAR	~7500M			FZB	8:10
8	7080	MFX, FÖRSÄNKAT, PH	965	7046	4.8	OBEH.	7:10
8	7080	MFX, FÖRSÄNKAT, PH	965	7046	A2		7:45
8	7081	MFX, FÖRSÄNKAT, PH	965	7046	4.8	FZB	7:9
8	7081	MFX, FÖRSÄNKAT, PH	965	7046	A4		7:45
9	7090	MFX, FÖRSÄNKAT, POZI	965	7046	A2		7:45
9	7091	MFX, FÖRSÄNKAT, POZI	965	7046	4.8	FZB	7:9
9	7091	MFX, FÖRSÄNKAT, POZI	965	7046	A4		7:45
35	8210	MFX-TT, FÖRSÄNKAT, TAPTITE	7500M		A2		8:47
35	8210	MFX-TT, TAPTITE, FÖRSÄNKAT	7500M			FZB	8:9
3	6050	MHGS, HELGÄNGAD STÅNG	975		4.6	OBEH.	6:1
3	6050	MHGS, HELGÄNGAD STÅNG	975		A2		6:40
3	6050	MHGS, HELGÄNGAD STÅNG	975				6:70
3	6050	MHGS, HELGÄNGAD STÅNG	975				6:90
3	6050	MHGS, HELGÄNGAD STÅNG	975				6:80
3	6051	MHGS, HELGÄNGAD STÅNG	975		4.6	FZB	6:1
3	6051	MHGS, HELGÄNGAD STÅNG	975		A4		6:40
3	6052	MHGS, HELGÄNGAD STÅNG	975		4.6	FZV	6:1
3	6053	MHGS, HELGÄNGAD STÅNG	975		5.8	OBEH.	6:2
3	6054	MHGS, HELGÄNGAD STÅNG	975		5.8	FZB	6:2
3	6055	MHGS, HELGÄNGAD STÅNG	975		5.8	FZV	6:2
3	6056	MHGS, HELGÄNGAD STÅNG	975		8.8	OBEH.	6:3
3	6057	MHGS, HELGÄNGAD STÅNG	975		8.8	FZB	6:3
3	6058	MHGS, HELGÄNGAD STÅNG	975		8.8	FZV	6:3
3	6070	MHGS, HELGÄNGAD STÅNG	975		10.9	OBEH.	6:3
3	6073	MHGS, HELGÄNGAD STÅNG	975		12.9	OBEH.	6:3

SWEBOLT AB

TEL. 08-584 909 60 FAX. 08-583 581 82

BILD	ART.GR.	BENÄMNING	DIN	ISO	KVAL	YTBEH	SIDA
3	6080	MHGS, UNDERSKUREN			5.8	OBEH.	6:2
8	3170	MHM, HATTMUTTER	1587		6	OBEH.	3:10
8	3170	MHM, HATTMUTTER	1587		A2		3:41
8	3170	MHM, HATTMUTTER	1587			OBEH.	3:51
8	3170	MHM, HATTMUTTER	1587				3:90
8	3170	MHM, HATTMUTTER	1587				3:80
8	3171	MHM, HATTMUTTER	1587		6	FZB	3:10
8	3171	MHM, HATTMUTTER	1587		A4		3:41
8	3171	MHM, HATTMUTTER	1587			FÖRNICKLAD	3:51
8	3172	MHM, HATTMUTTER	1587			FÖRKROMAD	3:51
9	3182	MHMP, HATTMU., PLÅTKAPSEL	~1587			OBEH.	3:21
9	3183	MHMP, HATTMU., PLÅTKAPSEL	~1587			FZB	3:21
5	6100	MHPS, HELGÄNGAD PINNSKRUV	976		A2		6:41
5	6101	MHPS, HELGÄNGAD PINNSKRUV	976		A4		6:41
5	6200	MHPS, HELGÄNGAD PINNSKRUV			4.6	OBEH.	6:9
5	6201	MHPS, HELGÄNGAD PINNSKRUV			4.6	FZB	6:9
5	6210	MHPS, HELGÄNGAD PINNSKRUV			5.8	OBEH.	6:10
5	6211	MHPS, HELGÄNGAD PINNSKRUV			5.8	FZB	6:10
5	6212	MHPS, HELGÄNGAD PINNSKRUV			5.8	FZV	6:10
5	6220	MHPS, HELGÄNGAD PINNSKRUV			8.8	OBEH.	6:11
5	6221	MHPS, HELGÄNGAD PINNSKRUV			8.8	FZB	6:11
5	6222	MHPS, HELGÄNGAD PINNSKRUV			8.8	FZV	6:11
5	6240	MHPS, HELGÄNGAD PINNSKRUV			10.9	OBEH.	6:23
5	6241	MHPS, HELGÄNGAD PINNSKRUV			10.9	FZB	6:23
3	7020	MKFS, KULLERFÖRSÄNK	964	2010	A2		7:43
3	7020	MKFS, KULLERFÖRSÄNK	964	2010			7:62
3	7020	MKFS, KULLERFÖRSÄNK	964	2010			7:81
3	7020	MKFS, KULLERFÖRSÄNK	964	2010			7:71
3	7021	MKFS, KULLERFÖRSÄNK	964	2010	A4		7:43
3	7021	MKFS, KULLERFÖRSÄNK	964	2010		FÖRNICKLAD	7:62
3	7023	MKFS, KULLERFÖRSÄNK, LITEN SKALLE		A2			
3	7021	MKFS, KULLERFÖRSÄNK	964	2010	4.8	FZB	7:5
43	8330	MKFSSG, GÄNGSKÄRANDE	7513G			OBEH.	8:16
43	8331	MKFSSG, GÄNGSKÄRANDE	7513G			FZB	8:16
30	7085	MKFT, KULLERFÖRSÄNK, STAR	~966	~7047	A2		7:49
30	7086	MKFT, KULLERFÖRSÄNK, STAR	~966	~7047	A4		7:49
55	8391	MKFT-GS, KULLERFÖRSÄNK, GÄNGSKÄRANDE			HV450	FZB	8:21
10	7110	MKFX, KULLERFÖRSÄNK, PH	966	7047	A2		7:46
10	7111	MKFX, KULLERFÖRSÄNK, PH	966	7047	4.8	FZB	7:10
11	7120	MKFX, KULLERFÖRSÄNK, POZI	966	7047	A2		7:46
11	7121	MKFX, KULLERFÖRSÄNK, POZI	966	7047	4.8	FZB	7:10
10	7111	MKFX, KULLERSÖRSÄNK, PH	966	7047	A4		7:46
11	7121	MKFX, KULLERSÖRSÄNK, POZI	966	7047	A4		7:46
6	3136	MKM, KRONM UTTER	935		8	FZB	3:9
6	3130	MKM, KRONMUTTER	935		6	OBEH.	3:9
6	3130	MKM, KRONMUTTER	935		A2		3:42
6	3130	MKM, KRONMUTTER	935			OBEH.	3:52
6	3131	MKM, KRONMUTTER	935		6	FZB	3:9
6	3131	MKM, KRONMUTTER	935		A4		3:42
6	3135	MKM, KRONMUTTER	935		8	OBEH.	3:9
6	3145	MKM, KRONMUTTER	935		10	OBEH.	3:9
5	7046	MKSS, METRISK KULLRIG STOR SKALLE			4.8	FZB	7:15
17	3225	ML4M	562		A2		3:42
17	3225	ML4M, LÅG FYRKANTMUTTER	562			OBEH.	3:10
17	3226	ML4M, LÅG FYRKANTMUTTER	562			FZB	3:10
2	3096	ML6M, LÅG ELEKTROMUTTER				FÖRNICKLAD	3:53
2	3065	ML6M, LÅG SEXKANTMUTTER	936		6	OBEH.	3:5
2	3066	ML6M, LÅG SEXKANTMUTTER	936		6	FZB	3:5
2	3067	ML6M, LÅG SEXKANTMUTTER	936		6	FZV	3:5
2	3085	ML6M, LÅG SEXKANTMUTTER	439B	4035	6	OBEH.	3:5

SWEBOLT AB

TEL. 08-584 909 60 FAX. 08-583 581 82

BILD	ART.GR.	BENÄMNING	DIN	ISO	KVAL	YTBEH	SIDA
2	3085	ML6M, LÅG SEXKANTMUTTER	439B	4035		OBEH.	3:52
2	3086	ML6M, LÅG SEXKANTMUTTER	439B	4035	6	FZB	3:5
2	3086	ML6M, LÅG SEXKANTMUTTER	439B	4035		FÖRNICKLAD	3:52
2	3087	ML6M, LÅG SEXKANTMUTTER	439B	4035	6	FZV	3:5
2	3085	ML6M, LÅGMUTTER	439	4035	A2		3:40
5	2060	MLC6S, LÅG INSEXSKRUV	7984		8.8	OBEH.	2:17
5	2060	MLC6S, LÅG INSEXSKRUV	7984		A2		2:70
5	2061	MLC6S, LÅG INSEXSKRUV	7984		8.8	FZB	2:18
5	2061	MLC6S, LÅG INSEXSKRUV	7984		A4		2:70
5	2062	MLC6S, LÅG INSEXSKRUV	7984		10.9	OBEH.	2:21
4	2050	MLC6SE, LÅG INSEXSKRUV	6912		8.8	OBEH.	2:19
4	2050	MLC6SE, LÅG INSEXSKRUV	6912		A2		2:69
4	2051	MLC6SE, LÅG INSEXSKRUV	6912		8.8	FZB	2:20
4	2051	MLC6SE, LÅG INSEXSKRUV	6912		A4		2:69
16	2170	MLC6SS, LÅGSTOR SKALLE, INSEX.			10.9	OBEH.	2:34
16	2171	MLC6SS, LÅGSTOR SKALLE, INSEX.			10.9	FZB	2:34
22	2210	MLCTS, LÅG INV STAR SKRUV	~7984		8.8	OBEH.	2:39
22	2211	MLCTS, LÅG INV STAR SKRUV	~7984		8.8	FZB	2:39
10	3185	MLHM, LÅG HATTMUTTER	917		6	OBEH.	3:21
10	3185	MLHM, LÅG HATTMUTTER	917		A2		3:44
10	3185	MLHM, LÅG HATTMUTTER	917			OBEH.	3:54
10	3185	MLHM, LÅG HATTMUTTER	917				3:81
10	3186	MLHM, LÅG HATTMUTTER	917		6	FZB	3:21
10	3186	MLHM, LÅG HATTMUTTER	917		A4		3:44
10	3186	MLHM, LÅG HATTMUTTER	917			FÖRNICKLAD	3:54
7	3150	MLKM, LÅG KRONMUTTER	937		8	OBEH.	3:20
7	3150	MLKM, LÅG KRONMUTTER	937		A2		3:44
7	3151	MLKM, LÅG KRONMUTTER	937		8	FZB	3:20
7	3151	MLKM, LÅG KRONMUTTER	937		A4		3:44
22	15570	MONTAGESKRUV, KULLRIG				FZB	15:10
22	15571	MONTAGESKRUV, KULLRIG				VIT	15:10
1	6000	MPS, PINNSKRUV	SS1460		5.8	OBEH.	6:7
1	6000	MPS, PINNSKRUV	SS1460		A2		6:47
2	6000	MPS, PINNSKRUV	SS1460				6:60
1	6001	MPS, PINNSKRUV	SS1460		5.8	FZB	6:7
1	6001	MPS, PINNSKRUV	SS1460		A4		6:47
1	6002	MPS, PINNSKRUV	SS1460		5.8	FZV	6:7
1	6003	MPS, PINNSKRUV	SS1460		8.8	OBEH.	6:8
1	6004	MPS, PINNSKRUV	SS1460		8.8	FZB	6:8
1	6005	MPS, PINNSKRUV	SS1460		10.9	OBEH.	6:8
2	6030	MPS, PINNSKRUV	938		5.8	OBEH.	6:14
2	6030	MPS, PINNSKRUV	938		A2		6:45
2	6030	MPS, PINNSKRUV	938				6:61
2	6031	MPS, PINNSKRUV	938		5.8	FZB	6:14
2	6031	MPS, PINNSKRUV	938		A4		6:43
2	6032	MPS, PINNSKRUV	938		8.8	OBEH.	6:15
2	6033	MPS, PINNSKRUV	938		8.8	FZB	6:15
2	6034	MPS, PINNSKRUV	938		10.9	OBEH.	6:16
2	6035	MPS, PINNSKRUV	939		5.8	OBEH.	6:16
2	6035	MPS, PINNSKRUV	939		A2		6:46
2	6035	MPS, PINNSKRUV	939				6:61
2	6036	MPS, PINNSKRUV	939		5.8	FZB	6:17
2	6036	MPS, PINNSKRUV	939		A4		6:44
2	6037	MPS, PINNSKRUV	939		8.8	OBEH.	6:18
2	6038	MPS, PINNSKRUV	939		8.8	FZB	6:18
2	6039	MPS, PINNSKRUV	939		10.9	OBEH.	6:19
28	7052	MRT, CYL. KULLERSK., STAR	~7985	~7045	4.8	OBEH.	7:12
28	7053	MRT, CYL. KULLERSK., STAR	~7985	~7045	4.8	FZB	7:12
28	7055	MRT, CYL. KULLERSK., STAR	~7985	~7045	8.8	FZB	7:12

SWEBOLT AB

TEL. 08-584 909 60 FAX. 08-583 581 82

BILD	ART.GR.	BENÄMNING	DIN	ISO	KVAL	YTBEH	SIDA
28	7052	MRT, CYL. KULLERSKALLE, STAR~7985		~7045	A2		7:47
28	7053	MRT, CYL. KULLERSKALLE, STAR~7985		~7045	A4		7:47
54	8386	MRT-GS, KULLRIG, GÄNGSKÄRANDE, STAR			HV450	FZB	8:21
37	8208	MRT-TT, TAPTITE, KULLRIG, STAR~7500C				FZB	8:10
14	7150	MRX Z1, OFÖRLORBAR BR.	7985 Z1/6902A		4.8	FZB	7:16
15	7160	MRX Z4, OFÖRLORBAR LÄSBR.	7985 Z4/6905		4.8	FZB	7:16
7	7061	MRX, CYL. KULLERSK., POZI	7985	7045	4.8	FZB	7:9
6	7050	MRX, CYL. KULLERSKALLE, PH	7985	7045	4.8	OBEH.	7:9
6	7050	MRX, CYL. KULLERSKALLE, PH	7985	7045	A2		7:44
6	7051	MRX, CYL. KULLERSKALLE, PH	7985	7045	4.8	FZB	7:9
6	7051	MRX, CYL. KULLERSKALLE, PH	7985	7045	A4		7:44
7	7060	MRX, CYL. KULLERSKALLE, POZI	7985	7045	A2		7:44
7	7061	MRX, CYL. KULLERSKALLE, POZI	7985	7045	A4		7:44
6	7053	MRX, LITEN CYL. KULLERSK. PH	~7985	~7045	4.8	FZB	7:11
31	7111	MRXC, COMBISPÅRSKRUV + PH				FZB	7:19
50	8366	MRX-GS, KULLRIG, GÄNGSKÄRANDE, PH			HV450	FZB	8:19
34	8205	MRX-TT, KULLRIG, TAPTITE	7500C		A2		8:47
34	8205	MRX-TT, TAPTITE, KULLRIG	7500C			FZB	8:9
4	7031	MSCS, STOR CYL SKALLE	85	1580	4.8	FZB	7:7
4	7033	MSCS, STOR CYL SKALLE	85	1580	8.8	FZB	7:8
4	7030	MSCS, STOR CYL. SKALLE	85	1580	A2		7:51
4	7030	MSCS, STOR CYL. SKALLE	85	1580			7:63
4	7030	MSCS, STOR CYL. SKALLE	85	1580			7:81
4	7031	MSCS, STOR CYL. SKALLE	85	1580	A4		7:52
4	7031	MSCS, STOR CYL. SKALLE	85	1580		FÖRNICKLAD	7:63
8	15020	MSI, MONTAGESKRUV				FZB	15:3
8	15021	MSI, MONTAGESKRUV				VIT	15:3
8	15022	MSI, MONTAGESKRUV				SVART	15:3
9	15025	MSII, MONTAGESKRUV m. BORRSPETS				FZB	15:3
9	15026	MSII, MONTAGESKRUV m. BORRSPETS				VIT	15:3
9	15027	MSII, MONTAGESKRUV m. BORRSPETS				SVART	15:3
21	10140	MSK4F, 4-KANT m. FLÄNS	478		8.8	OBEH.	10:21
21	10142	MSK4F, 4-KANT m. FLÄNS	478		10.9	OBEH.	10:21
1	10001	MVBF, VAGNSBULT	603	8677	4.6	OBEH.	10:1
1	10001	MVBF, VAGNSBULT	603	8677	A2		10:41
1	10002	MVBF, VAGNSBULT	603	8677	4.6	FZB	10:1
1	10002	MVBF, VAGNSBULT	603	8677	A4		10:41
1	10003	MVBF, VAGNSBULT	603	8677	4.6	FZV	10:7
1	10004	MVBF, VAGNSBULT	603	8677	8.8	OBEH.	10:8
1	10005	MVBF, VAGNSBULT	603	8677	8.8	FZB	10:8
1	10006	MVBF, VAGNSBULT	603	8677	8.8	FZV	10:8
1	10001	MVBF, VAGSBULT	603	8677			10:60
3	10015	MVBFF, FÖRSÄNKT VAGNSBULT	605		4.6	OBEH.	10:10
3	10016	MVBFF, FÖRSÄNKT VAGNSBULT	605		4.6	FZB	10:10
3	10017	MVBFF, FÖRSÄNKT VAGNSBULT	608		4.6	OBEH.	10:11
3	10018	MVBFF, FÖRSÄNKT VAGNSBULT	608		8.8	OBEH.	10:11
2	10010	MVBFFK, FÖRS. m. KNASTER	604		4.6	OBEH.	10:9
2	10011	MVBFFK, FÖRS. m. KNASTER	604		4.6	FZB	10:9
4	10020	MVBFK, VAGNSB. m. KNASTER	607		4.6	OBEH.	10:12
4	10021	MVBFK, VAGNSB. m. KNASTER	607		4.6	FZB	10:12
5	6110	MVHGS, VARMHÅLLF. GÄNGST.	ASTM. A 193B7			OBEH.	6:5
5	6111	MVHPS, VARMHÅLLF. PINNSKR.	ASTM..A 193B7			OBEH.	6:5
12	3200	MVM, VINGMUTTER ADDUC	315			OBEH.	3:10
12	3201	MVM, VINGMUTTER ADDUC	315			FZB	3:10
6	6120	MVPS, VARMHÅLLFASTA	2510L 24CrMo V-57				6:6
1	4030	NB, NITBRICKA					4:80
2	4030	NB, NITBRICKA				OBEH.	4:4
2	4031	NB, NITBRICKA				FZB	4:4
9	4131	NL, NORDLOCKBRICKA, LIMMAD			A4		4:43
9	4131	NL, SMÅ LIMMADE	NORDLOCK			FZB	4:8

SWEBOLT AB

TEL. 08-584 909 60 FAX. 08-583 581 82

BILD	ART.GR.	BENÄMNING	DIN	ISO	KVAL	YTBEH	SIDA
9	4130	NL, SMÅ OLIMMADE				OBEH.	4:8
9	4133	NL, STORA LIMMADE				FZB	4:8
9	4132	NL, STORA OLIMMADE				OBEH.	4:8
34	3212	NM, NITMUTTER				OBEH.	3:25
34	3213	NM, NITMUTTER				FZB	3:25
20	15401	NYLONPLUGG					15:8
29	13915	P6BMKOS, PLAN KORT, 6-KANT, ÖPPEN			STÅL	OBEH.	13:80
29	13916	P6BMKOS, PLAN KORT, 6-KANT, ÖPPEN			STÅL	FZG	13:80
29	13917	P6BMKOS, PLAN KORT, 6-KANT, ÖPPEN			STÅL	FZB	13:80
28	13905	P6BMSS, PLAN 6-KANT, SLUTEN			STÅL	OBEH.	13:79
28	13906	P6BMSS, PLAN 6-KANT, SLUTEN			STÅL	FZG	13:79
28	13907	P6BMSS, PLAN 6-KANT, SLUTEN			STÅL	FZB	13:79
27	13900	P6BMÖS, PLAN 6-KANT, ÖPPEN			STÅL	OBEH.	13:79
27	13901	P6BMÖS, PLAN 6-KANT, ÖPPEN			STÅL	FZG	13:79
27	13902	P6BMÖS, PLAN 6-KANT, ÖPPEN			STÅL	FZB	13:79
8	2080	P6SS, STOPPSKRUV PLAN	913	4026	45HRC	OBEH.	2:27
8	2080	P6SS, STOPPSKRUV PLAN	913	4026	A2		2:73
8	2081	P6SS, STOPPSKRUV PLAN	913	4026	45HRC	FZB	2:29
8	2081	P6SS, STOPPSKRUV PLAN	913	4026	A4		2:74
25	3250	PALM, PALMUTTER	7967	1479		OBEH.	3:16
25	3250	PALM, PALMUTTER	7967		A2		3:45
25	3251	PALM, PALMUTTER	7967	1479		FZB	3:16
25	3251	PALM, PALMUTTER	7967		A4		3:45
17	5100	PB, PASSBRICKA, SHIMS	988			OBEH.	5:2
1	4000	PB, PLANBRICKA	125	7089			4:90
1	4050	PB, PLANBRICKA	433				4:91
2	4050	PB, PLANBRICKA	433	7092	HV250	OBEH.	4:9
2	4050	PB, PLANBRICKA	433	7092			4:61
2	4051	PB, PLANBRICKA	433	7092	HV250	FZB	4:9
2	4051	PB, PLANBRICKA	433	7092		FÖRNICKLAD	4:61
2	4053	PB-FRP, PLANBRICKA FÖR FRP	433	7092	A2		4:44
2	4054	PB-FRP, PLANBRICKA FÖR FRP	7349			FZB	4:21
2	4054	PB-FRP, PLANBRICKA FÖR FRP	433	7092	A4		4:44
2	4058	PBG, PLANBRICKA GROV	1441			OBEH.	4:12
2	4059	PBG, PLANBRICKA GROV	1441			FZB	4:12
2	4055	PBM, PLANBRICKA MEDEL	1440			OBEH.	4:12
2	4056	PBM, PLANBRICKA MEDEL	1440			FZB	4:12
22	13721	PBMSAL, PLAN SKALLE, SLUTEN			ALU		13:72
22	13705	PBMSS, PLAN SKALLE, SLUTEN			STÅL	OBEH.	13:70
22	13706	PBMSS, PLAN SKALLE, SLUTEN			STÅL	FZG	13:70
22	13707	PBMSS, PLAN SKALLE, SLUTEN			STÅL	FZB	13:70
22	13725	PBMSSAL, PLAN SKALLE SMALLGRIP, SLUTEN			ALU		13:72
22	13710	PBMSSS, PLAN SKALLE SMALLGRIP, SLUTEN			STÅL	OBEH.	13:71
22	13711	PBMSSS, PLAN SKALLE SMALLGRIP, SLUTEN			STÅL	FZG	13:71
22	13712	PBMSSS, PLAN SKALLE SMALLGRIP, SLUTEN			STÅL	FZB	13:71
21	13724	PBMSÖAL, PLAN SKALLE SMALLGRIP, ÖPPEN			ALU		13:72
21	13715	PBMSÖS, PLAN SKALLE SMALLGRIP, ÖPPEN			STÅL	OBEH.	13:71
21	13716	PBMSÖS, PLAN SKALLE SMALLGRIP, ÖPPEN			STÅL	FZG	13:71
21	13717	PBMSÖS, PLAN SKALLE SMALLGRIP, ÖPPEN			STÅL	FZB	13:71
21	13720	PBMÖAL, PLAN SKALLE, ÖPPEN			ALU		13:72
21	13730	PBMÖRS, PLAN SKALLE ÖPPEN			ROSTFRI		13:72
25	13850	PBMÖRS, PLAN SKALLE, RILLAD, ÖPPEN			STÅL	OBEH.	13:78
25	13851	PBMÖRS, PLAN SKALLE, RILLAD, ÖPPEN			STÅL	FZG	13:78
25	13852	PBMÖRS, PLAN SKALLE, RILLAD, ÖPPEN			STÅL	FZB	13:78
21	13700	PBMÖS, PLAN SKALLE, ÖPPEN			STÅL	OBEH.	13:70
21	13701	PBMÖS, PLAN SKALLE, ÖPPEN			STÅL	FZG	13:70
21	13702	PBMÖS, PLAN SKALLE, ÖPPEN			STÅL	FZB	13:70
21	13732	PBMÖSRS, PLAN SKALLE SMALLGRIP, ÖPPEN			ROSTFRI		13:72
1	4260	PBT, PASSBRICKA	7349		A2		4:44
1	4261	PBT, PASSBRICKA	7349		A4		4:44

SWEBOLT AB

TEL. 08-584 909 60 FAX. 08-583 581 82

BILD	ART.GR.	BENÄMNING	DIN	ISO	KVAL	YTBEH	SIDA	
17	17042	PGI, PRESSGÄNGINSATS FÖR TERMOPLAST					16:7	
16	17040	PGIH, PRESSGÄNGINSATS m. HULLINGAR					16:6	
19	17046	PGIHL, PRESSGÄNGINSATS, TYP H-L					16:7	
18	17044	PGIL, PRESSGÄNGINSATS FÖR ULTRALJUDSMONTAG					16:7	
52	4680	PLASTFOT, TYP VL				SVART	4:92	
19	15400	PLASTPLUGG					15:8	
33	3295	PM, PRESSMUTTER				OBEH.	3:25	
33	3295	PM, PRESSMUTTER			A2		3:46	
33	3296	PM, PRESSMUTTER				FZB	3:25	
32	3290	PMA, PRESSMUTTER (ANCOR)				OBEH.	3:25	
32	3290	PMA, PRESSMUTTER (ANCOR)			A1		3:46	
32	3290	PMA, PRESSMUTTER (ANCOR)					3:81	
32	3291	PMA, PRESSMUTTER (ANCOR)				FZB	3:25	
34	3310	PMK, PRESSMUTTER (KALEI)				OBEH.	3:25	
34	3310	PMK, PRESSMUTTER (KALEI)			A2		3:46	
34	3311	PMK, PRESSMUTTER (KALEI)				FZB	3:25	
19	61240	POPINITBARR, Nr. 119, DUBBEL	1897			STÅL	HSS	18:26
18	61230	POPINITBARR, Nr. 123, ENKEL	1897			STÅL	HSS	18:26
14	11130	PRYM, SPIRALSPÄNNSTIFT	7343	8750				11:6
14	11130	PRYM, SPIRALSPÄNNSTIFT	7343	8750	1.4310			11:45
14	11135	PRYM, SPIRALSPÄNNSTIFT, KRAFTIG	7344	8748				11:10
42	10425	PS, PENDELSKRUV					FZB	10:5
16	7170	PSS, PLAN m. SPÅR	551	4766			OBEH.	7:14
16	7170	PSS, PLAN m. SPÅR	551	4766	A1			7:54
16	7170	PSS, PLAN m. SPÅR	551	4766				7:65
16	7170	PSS, PLAN m. SPÅR	551	4766				7:81
16	7171	PSS, PLAN m. SPÅR	551	4766			FZB	7:14
16	7171	PSS, PLAN m. SPÅR	551	4766	A4			7:54
1	4000	RB, PLANBRICKA	125A+B	7089/7090				4:60
1	4000	RB, PLANBRICKA	125	7089				4:70
1	4000	RB, PLANBRICKA	125	7089				4:80
1	4000	RB, PLANBRICKA	125A	7089				4:110
1	4000	RB, PLANBRICKA	125A	7089				4:116
1	4001	RB, PLANBRICKA	125A+B	7089/7090			FÖRNICKLAD	4:60
1	4003	RB, PLANBRICKA	125A	7089	HV200		OBEH.	4:1
1	4004	RB, PLANBRICKA	125A	7089	HV200		FZB	4:1
1	4005	RB, PLANBRICKA	125A	7089	HV200		FZV	4:1
1	4006	RB, PLANBRICKA	125		HV140		OBEH.	4:1
1	4007	RB, PLANBRICKA	125		HV140		FZB	4:1
1	4008	RB, PLANBRICKA	125		HV140		FZV	4:1
1	4310	RB, RINGBRICKA					FÖRNICKLAD	4:61
33	4253	RB4, BRICKA m. 4-KANTHÅL	440V				OBEH.	4:17
33	4254	RB4, BRICKA m. 4-KANTHÅL	440V				FZB	4:17
21	13910	RBMS, RÖRANPASSAD				STÅL	OBEH.	13:80
21	13911	RBMS, RÖRANPASSAD				STÅL	FZG	13:80
21	13912	RBMS, RÖRANPASSAD				STÅL	FZB	13:80
2	4069	RBS, STOR PLANBRICKA	9021	7093			FZV	4:3
2	4070	RBS, STOR PLANBRICKA	9021	7093			OBEH.	4:3
2	4070	RBS, STOR PLANBRICKA	9021		A2			4:40
2	4070	RBS, STOR PLANBRICKA	9021	7093				4:60
2	4070	RBS, STOR PLANBRICKA	9021	7093				4:90
2	4070	RBS, STOR PLANBRICKA	9021	7093				4:70
2	4070	RBS, STOR PLANBRICKA	9021	7093				4:80
2	4071	RBS, STOR PLANBRICKA	9021	7093			FZB	4:3
2	4071	RBS, STOR PLANBRICKA	9021		A4			4:40
2	4071	RBS, STOR PLANBRICKA	9021	7093			FÖRNICKLAD	4:60
40	10460	RF, FÖRSLUTNING	7605				OBEH.	10:35
40	10461	RF, FÖRSLUTNING	7605				FZB	10:35

SWEBOLT AB

TEL. 08-584 909 60 FAX. 08-583 581 82

BILD	ART.GR.	BENÄMNING	DIN	ISO	KVAL	YTBEH	SIDA
27	4215	RFB, FÖRSLUTNINGSBR. RAK	443	A		OBEH.	4:16
27	4216	RFB, FÖRSLUTNINGSBR. RAK	443	B		OBEH.	4:16
27	4215	RFB, FÖRSLUTNINGSBRICKA RAK	443A		A2		4:50
2	12011	RK, RUNDAD KIL, H7	6885A				12:1
2	12010	RK, RUNDAD KIL, H9	6885A				12:1
2	12009	RK, RUNDKIL	6885A		A2		12:41
2	12010	RK, RUNDKIL	6885A		A4		12:41
11	9060	RK, RUNDKROK, TRÄGÄNGA				OBEH.	9:10
11	9061	RK, RUNDKROK, TRÄGÄNGA				FZB	9:10
17	13600	RKBL-AL/AL	ALU		ALU		13:53
17	13602	RKBL-AL/AL, SVART	ALU		ALU	5010	13:55
17	13601	RKBL-AL/AL, VIT	ALU		ALU	9010	13:54
26	3255	RM, RUND LÄTTRAD MUTTER	466			OBEH.	3:23
26	3255	RM, RUND LÄTTRAD MUTTER	466		A2		3:45
26	3255	RM, RUND LÄTTRAD MUTTER	466			OBEH.	3:55
26	3255	RM, RUND LÄTTRAD MUTTER	466				3:91
26	3256	RM, RUND LÄTTRAD MUTTER	466			FZB	3:23
26	3256	RM, RUND LÄTTRAD MUTTER	466		A4		3:45
26	3256	RM, RUND LÄTTRAD MUTTER	466			FÖRNICKLAD	3:55
1	3058	RM6M, RÖRGÄNGA	~934	~4033	6	OBEH.	3:32
1	3060	RM6M, RÖRGÄNGA	431		6	OBEH.	3:33
1	3061	RM6M, RÖRGÄNGA	431		6	FZB	3:33
29	3270	RMH, RUNDMU. m. SPÄNT HÅL	547			OBEH.	3:23
29	3271	RMH, RUNDMU. m. SPÄNT HÅL	547			FZB	3:23
1	3060	RML6M, RÖRGÄNGA	431		A2		3:49
1	3061	RML6M, RÖRGÄNGA	431		A4		3:49
28	3265	RMS, RUND SLITSMUTTER	546			OBEH.	3:23
28	3265	RMS, RUND SLITSMUTTER	546		A1		3:46
28	3265	RMS, RUND SLITSMUTTER	546			OBEH.	3:55
28	3266	RMS, RUND SLITSMUTTER	546			FZB	3:23
28	3266	RMS, RUND SLITSMUTTER	546			FÖRNICKLAD	3:55
30	3275	RMSH, RUNDMU. m. SIDOHÅL	548			OBEH.	3:24
30	3276	RMSH, RUNDMU. m. SIDOHÅL	548			FZB	3:24
19	13060	RN, RÖRNIT	7339			FÖRNICK.	13:123
20	13065	RN, RÖRNIT	7340A				13:124
9	10050	RP 906, KONISK, INV. 6-KANT	906	M+R	5.8	OBEH.	10:2
9	10050	RP 906, KONISK, INV. 6-KANT	906	M+R	A2		10:42
9	10051	RP 906, KONISK, INV. 6-KANT	906	M+R	5.8	FOS	10:2
9	10052	RP 906, KONISK, INV. 6-KANT	906	M+R	5.8	FZB	10:2
9	10051	RP 906, KONISK, INV. 6-KANT	906	M+R	A4		10:42
10	10055	RP 908, INV. 6-KANT m. FLÄNS	908	M+R	5.8	OBEH.	10:2
10	10055	RP 908, INV. 6-KANT m. FLÄNS	908	M+R	A2		10:42
10	10056	RP 908, INV. 6-KANT m. FLÄNS	908	M+R	5.8	FOS	10:2
10	10056	RP 908, INV. 6-KANT m. FLÄNS	908	M+R	A4		10:42
10	10057	RP 908, INV. 6-KANT m. FLÄNS	908	M+R	5.8	FZB	10:2
11	10060	RP 908T, FLÄNS OCH TÄTNING	~908	M+R	5.8	OBEH.	10:15
12	10065	RP 910, 6-KANT	910	M+R	5.8	OBEH.	10:2
12	10065	RP 910, 6-KANT	910	M+R	A2		10:42
12	10066	RP 910, 6-KANT	910	M+R	5.8	FOS	10:2
12	10066	RP 910, 6-KANT	910	M+R	A4		10:42
12	10067	RP 910, 6-KANT	910	M+R	5.8	FZB	10:2
14	10075	RP 910M, 6-KANT, MAGNETISK	910	M+R	5.8	OBEH.	10:15
13	10070	RP 910T, 6-KANT m. TÄTNING	~910	M+R	5.8	OBEH.	10:15
15	10080	RP, 6-KANT, METRISK GÄNGA	7604A+C	5.8		OBEH.	10:17
15	10080	RP, 6-KANT, METRISK GÄNGA	7604A				10:62
15	10081	RP, 6-KANT, METRISK GÄNGA	7604A		5.8	FZB	10:17
15	10083	RP, 6-KANT, METRISK GÄNGA	7604C		5.8	FZB	10:17
16	10085	RP, 6-KANT, RÖRGÄNGA	7604C		5.8	FZB	10:17
10	11090	RP, RÄFFELPINNE	1473	8740			11:9
9	10050	RP-906, KONISK, INV. 6-KANT	906				10:61

SWEBOLT AB

TEL. 08-584 909 60 FAX. 08-583 581 82

BILD	ART.GR.	BENÄMNING	DIN	ISO	KVAL	YTBEH	SIDA
10	10055	RP-908, INV. 6-KANT m. FLÄNS	908				10:61
12	10065	RP-910, 6-KANT	910				10:61
12	11066	RP-910, 6-KANT	910			FÖRNICKLAD	10:61
8	11070	RPA, RÄFFELPINNE	1471	8744			11:8
9	11080	RPB, RÄFFELPINNE	1472	8745			11:8
7	11060	RPC, RÄFFELPINNE	1470	8739			11:8
12	11110	RPD, RÄFFELPINNE	1475	8742			11:9
11	11100	RPE, RÄFFELPINNE	1474	8741			11:9
20	4180	RRB, RÄFFLAD BRICKA schnorr				OBEH.	4:10
20	4180	RRB, RÄFFLAD BRICKA schnorr			A2		4:44
20	4180	RRB, RÄFFLAD BRICKA schnorr					4:120
20	4181	RRB, RÄFFLAD BRICKA schnorr				FZB	4:10
8	5050	RS, SPÄRRYTTARE, AXEL	6799			OBEH.	5:1
8	5050	RS, SPÄRRYTTARE, AXEL	6799		A2		5:41
8	5050	RS, SPÄRRYTTARE, AXEL	6799		KOPPAR		5:60
8	5050	RS, SPÄRRYTTARE, AXEL	6799		TENN - BRONS		5:60
8	5051	RS, SPÄRRYTTARE, AXEL	6799			FZB	5:1
8	5051	RS, SPÄRRYTTARE, AXEL	6799		MAGNET. BRONS		5:60
11	2120	RSK6SS, STOPPSKRUV SKÅLAD	RÖRG.			OBEH.	2:51
38	3306	RSM, SVETSMU. HÅL TYP "D"				OBEH.	3:14
38	3307	RSM, SVETSMU. HÅL TYP "D"				FZB	3:14
37	3304	RSM, SVETSMU. PLAN TYP "C"				OBEH.	3:14
37	3305	RSM, SVETSMU. PLAN TYP "C"				FZB	3:14
35	3300	RSM, SVETSMU. VÅRTA UNDERSIDA TYP "A"				OBEH.	3:13
35	3301	RSM, SVETSMU. VÅRTA UNDERSIDA TYP "A"				FZB	3:13
36	3302	RSM, SVETSMU. VÅRTA ÖVERSIDA TYP "B"				OBEH.	3:13
36	3303	RSM, SVETSMU. VÅRTA ÖVERSIDA TYP "B"				FZB	3:13
37	3300	RSM, SVETSMUTTER PLAN TYP "C"			A2		3:47
23	8062	RTB, KULLRIG, BORRSP., STAR	7504N			FZB	8:14
11	8023	RTK, TRUBBIG, STAR	7981F	7049F		FZB	8:3
64	8443	RTK-COMBI				FZB	8:12
8	8015	RTS, KULLRIG, SPETS, STAR	7981C	7049C		FZB	8:3
8	8015	RTS, KULLRIG, SPETS, STAR	7981C	7049C	A2		8:45
8	8016	RTS, KULLRIG, SPETS, STAR	7981C	7049C	A4		8:46
63	8441	RTS-COMBI				FZB	8:12
46	3830	RUND SKARVMUTTER				OBEH.	3:12
46	3830	RUND SKARVMUTTER			A2		3:48
46	3831	RUND SKARVMUTTER				FZB	3:12
46	3831	RUND SKARVMUTTER			A4		3:48
46	3832	RUND SKARVMUTTER				FZV	3:12
13	5080	RW, KLÄMLÅSRING, HÅL	7993B			OBEH.	5:9
13	5081	RW, KLÄMLÅSRING, HÅL	7993B			MFZG	5:9
21	8060	RXB, KULLRIG, BORRSP., PH	7504N			FZB	8:6
22	8061	RXB, KULLRIG, BORRSP., POZI	7504N			FZB	8:6
21	8060	RXB, KULLRIG, BORRSPETS	7504N		A2		8:49
9	8020	RXK, KULLRIG, TRUBBIG, PH	7981F	7049F		FZB	8:2
10	8021	RXK, KULLRIG, TRUBBIG, POZI	7981F	7049F		FZB	8:2
6	8011	RXS, KULLRIG, SPETS, PH	7981C	7049C		FZB	8:1
6	8011	RXS, KULLRIG, SPETS, PH	7981C	7049C	A2		8:43
6	8013	RXS, KULLRIG, SPETS, PH	7981C	7049C	A4		8:44
7	8012	RXS, KULLRIG, SPETS, POZI	7981C	7049C		FZB	8:1
7	8012	RXS, KULLRIG, SPETS, POZI	7981C	7049C	A2		8:43
7	8014	RXS, KULLRIG, SPETS, POZI	7981C	7049C	A4		8:44
48	8356	RXSB, KULLRIG SKALLE, OFÖRFLORBAR BRICKA				FZB	8:18
39	8220	RXSF, KULLRIG MED FLÄNS	~7981			FZB	8:7
49	8361	RXS-GS, KULLRIG, GÄNGSKÄRANDE, PH			HV450	FZB	8:19
24	15580	RÄNNKROKSKRUV				FZB	15:10
6	4100	S4B, FYRKANTBRICKA	436			OBEH.	4:8
6	4100	S4B, FYRKANTBRICKA	436		A2		4:46
6	4101	S4B, FYRKANTBRICKA	436			FZB	4:8

SWEBOLT AB

TEL. 08-584 909 60 FAX. 08-583 581 82

BILD	ART.GR.	BENÄMNING	DIN	ISO	KVAL	YTBEH	SIDA
6	4101	S4B, FYRKANTBRICKA	436		A4		4:46
6	4102	S4B, FYRKANTBRICKA	436			FZV	4:8
9	2090	S6SS, STOPPSKRUV m. SPETS	914	4027	45HRC	OBEH.	2:27
9	2090	S6SS, STOPPSKRUV m. SPETS	914	4027	A2		2:73
9	2091	S6SS, STOPPSKRUV m. SPETS	914	4027	45HRC	FZB	2:29
9	2091	S6SS, STOPPSKRUV m. SPETS	914	4027	A4		2:74
12	5072	SB, LÅSRING, AXEL				OBEH.	5:9
12	5073	SB, LÅSRING, AXEL				FZB	5:9
12	5070	SB, LÅSRING, AXEL RUND	7993A			OBEH.	5:9
12	5071	SB, LÅSRING, AXEL RUND	7993A			MFZG	5:9
15	1291	SB, STÅLBYGGNADSBULT			8.8	FZV	1:43
3	4072	SBB, STÅLBYGGNADSBRICKA	6916	7416	C45	OBEH.	4:3
3	4073	SBB, STÅLBYGGNADSBRICKA	6916	7416	C45	FZB	4:3
3	4074	SBB, STÅLBYGGNADSBRICKA	6916	7416	C45	FZV	4:3
8	1194	SBL, STÅLBYGGNADSBULT	7990		4.6-5.6	FZB	1:49
8	1195	SBL, STÅLBYGGNADSBULT	7990		4.6-5.6	FZV	1:50
8	1193	SBL, STÅLBYGGNANDBULT	7990		4.6-5.6	OBEH.	1:48
34	4075	SBRB, STÅLBYGGNADSBRICKA HÖG				FZV	4:3
34	4076	SBRB, STÅLBYGGNADSBRICKA	7989			OBEH.	4:3
34	4077	SBRB, STÅLBYGGNADSBRICKA	7989			FZB	4:3
34	4078	SBRB, STÅLBYGGNADSBRICKA	7989			FZV	4:3
15	14380	SCHACKEL			A2		14:47
15	14380	SCHACKEL, FÖR KEDJA				FZV	14:9
15	14381	SCHACKEL, RUND TYP				FZV	14:9
15	14381	SCHACKEL, RUND TYP			A4		14:47
30	13925	SF6BMOAL, SJÄLVFÖRSÄNKANDE, ÖPPEN			ALU		13:81
30	13920	SF6BMOS, SJÄLVFÖRSÄNKANDE, ÖPPEN			STÅL	OBEH.	13:81
30	13921	SF6BMOS, SJÄLVFÖRSÄNKANDE, ÖPPEN			STÅL	FZG	13:81
30	13922	SF6BMOS, SJÄLVFÖRSÄNKANDE, ÖPPEN			STÅL	FZB	13:81
26	13935	SFBMROS, SJÄLVFÖRS. M. RILLOR, ÖPPEN			STÅL	OBEH.	13:82
26	13936	SFBMROS, SJÄLVFÖRS. M. RILLOR, ÖPPEN			STÅL	FZG	13:82
26	13937	SFBMROS, SJÄLVFÖRS. M. RILLOR, ÖPPEN			STÅL	FZB	13:82
23	13810	SFBMRS, SJÄLVFÖRSÄNKANDE, ÖPPEN			ROSTFRI		13:76
23	13800	SFBMS, SJÄLVFÖRSÄNKANDE ÖPPEN			STÅL	OBEH.	13:77
23	13801	SFBMS, SJÄLVFÖRSÄNKANDE ÖPPEN			STÅL	FZG	13:77
23	13802	SFBMS, SJÄLVFÖRSÄNKANDE ÖPPEN			STÅL	FZB	13:77
38	4233	SFÄRISK BRICKA	6319C			OBEH.	4:18
38	4234	SFÄRISK BRICKA	6319D			OBEH.	4:18
1	5000	SGA, LÅSRING, AXEL	471			OBEH.	5:1
1	5000	SGA, LÅSRING, AXEL	471		A2		5:40
1	5001	SGA, LÅSRING, AXEL	471			MFZG	5:1
1	5001	SGA, LÅSRING, AXEL	471		A4		5:40
2	5010	SGH, LÅSRING, HÅL	472			OBEH.	5:1
2	5010	SGH, LÅSRING, HÅL	472		A2		5:40
2	5011	SGH, LÅSRING, HÅL	472			MFZG	5:1
2	5011	SGH, LÅSRING, HÅL	472		A4		5:40
4	5022	SGHL, LÅSRING m. LÄPP, AXEL	984			OBEH.	5:6
10	17026	SGI, SPLITGÄNGINSATS FÖR PLAST					16:5
11	17028	SGIF, SPLITGÄNGINSATS MED FLÄNS					16:5
12	17030	SGIT, SPLITGÄNGINSATS FÖR TERMOPLAST					16:5
4	12030	SK, SKALLKIL	6887				12:3
43	4600	SK, SKYDDSKAPSLEL FÖR SKRUV o MUTTER				SVART	4:97
43	4601	SK, SKYDDSKAPSLEL FÖR SKRUV o MUTTER				VIT	4:97
43	4602	SK, SKYDDSKAPSLEL FÖR SKRUV o MUTTER				RÖD	4:97
43	4603	SK, SKYDDSKAPSLEL FÖR SKRUV o MUTTER				GRÖN	4:97
43	4604	SK, SKYDDSKAPSLEL FÖR SKRUV o MUTTER				BEIGE	4:97
24	2073	SK6S, SÄKERHETSSKRUV m. INV TAPP		~7380	10.9	OBEH.	2:41
24	2073	SK6S, SÄKERHETSSKRUV m. INV TAPP		~7380	A2		2:76
11	2110	SK6SS, STOPPSKRUV SKÅLAD	916	4029	45HRC	OBEH.	2:28

SWEBOLT AB

TEL. 08-584 909 60 FAX. 08-583 581 82

BILD	ART.GR.	BENÄMNING	DIN	ISO	KVAL	YTBEH	SIDA
11	2110	SK6SS, STOPPSKRUV SKÅLAD	916	4029	A2		2:73
11	2111	SK6SS, STOPPSKRUV SKÅLAD	916	4029	45HRC	FZB	2:30
11	2111	SK6SS, STOPPSKRUV SKÅLAD	916	4029	A4		2:74
9	13351	SKBL-AL/AL	ALU		ALU		13:3
9	13350	SKBL-AL/ST	ALU		STÅL		13:7
9	13362	SKBL-AL/ST, SVART	ALU		STÅL	5010	13:25
9	13361	SKBL-AL/ST, VIT	ALU		STÅL	9010	13:25
9	13354	SKBL-KO/RF	KOPPAR		ROSTFRI		13:23
12	13390	SKBLMG-AL/ST	ALU		STÅL		13:36
9	13353	SKBL-RF/RF	ROSTFRI		ROSTFRI		13:24
16	13331	SKBLSM-AL/ST, STORT HUVUD	ALU		STÅL		13:43
9	13352	SKBL-ST/ST	STÅL		STÅL		13:22
44	10511	SKENSKRUV				FZB	10:31
23	15575	SKIVSKRUV				FZB	15:10
19	5090	SKLB, SNABBKLÄMBRICKA				OBEH.	5:10
19	5091	SKLB, SNABBKLÄMBRICKA				FZB	5:10
50	4670	SKRUVPLUGG, GPN 700, form A				GUL	4:92
19	7200	SKSS, SKÅLAD m. SPÅR	438	7436		OBEH.	7:14
19	7200	SKSS, SKÅLAD m. SPÅR	438	7436	A2		7:55
19	7201	SKSS, SKÅLAD m. SPÅR	438	7436		FZB	7:14
19	7201	SKSS, SKÅLAD m. SPÅR	438	7436	A4		7:55
44	4600	SKYDDSHUV				SVART	4:97
10	14180	SKYDDSHUV FÖR SMÖRJNIPPEL				NYLON	14:3
48	4640	SKYDDSHUV, FÖSÄNKT INSEX				SVART	4:98
48	4641	SKYDDSHUV, FÖSÄNKT INSEX				VIT	4:98
48	4642	SKYDDSHUV, FÖSÄNKT INSEX				GRÖN	4:98
48	4643	SKYDDSHUV, FÖSÄNKT INSEX				RÖD	4:98
48	4644	SKYDDSHUV, FÖSÄNKT INSEX				BEIGE	4:98
49	4650	SKYDDSHUV, INSEX				SVART	4:98
49	4651	SKYDDSHUV, INSEX				VIT	4:98
49	4652	SKYDDSHUV, INSEX				GRÖN	4:98
49	4653	SKYDDSHUV, INSEX				RÖD	4:98
49	4654	SKYDDSHUV, INSEX				BEIGE	4:98
45	4610	SKYDDSHUV, KULLRIG SKRUV				SVART	4:98
45	4611	SKYDDSHUV, KULLRIG SKRUV				VIT	4:98
45	4612	SKYDDSHUV, KULLRIG SKRUV				RÖD	4:98
45	4613	SKYDDSHUV, KULLRIG SKRUV				GRÖN	4:98
46	4620	SKYDDSHUV, POZI				SVART	4:98
46	4621	SKYDDSHUV, POZI				VIT	4:98
46	4622	SKYDDSHUV, POZI				RÖD	4:98
46	4623	SKYDDSHUV, POZI				GRÖN	4:98
46	4624	SKYDDSHUV, POZI				BEIGE	4:98
47	4630	SKYDDSHUV, SPÅR				SVART	4:98
47	4631	SKYDDSHUV, SPÅR				VIT	4:98
47	4632	SKYDDSHUV, SPÅR				RÖD	4:98
47	4633	SKYDDSHUV, SPÅR				GRÖN	4:98
47	4634	SKYDDSHUV, SPÅR				BEIGE	4:98
18		SKYDDSLOCK FÖR BLINDNIT			PLAST		13:60
42	4660	SKYDDSPLUGG				SVART	4:97
42	4661	SKYDDSPLUGG				VIT	4:97
42	4662	SKYDDSPLUGG				RÖD	4:97
42	4663	SKYDDSPLUGG				GRÖN	4:97
42	4664	SKYDDSPLUGG				BEIGE	4:97
42	4665	SKYDDSPLUGG, TYP B				GUL	4:97
53	4685	SKYDDSPLUGG, KONISK, TYP C				NATUR	4:94
51	4676	SKYDDSPROPP				BLÅ	4:92
6	14040	SL, SLANGKLAMMER	ABA		A2		14:19
6	14041	SL, SLANGKLAMMER	ABA		A4		14:19
6	14040	SL, SLANGKLAMMER ABA				FZB	14:16-18
2	15011	SLAGANKARE				FZB	15:1

SWEBOLT AB

TEL. 08-584 909 60 FAX. 08-583 581 82

BILD	ART.GR.	BENÄMNING	DIN	ISO	KVAL	YTBEH	SIDA
2	15011	SLAGANKARE			A4		15:20
2	15011	SLAGANKARE				OBEH.	15:20
2	15012	SLAGANKARE				FZV	
3	15010	SLAGDORN FÖR SLAGANKARE					15:1
21	15030	SLAGNIT				ALU/STÅL	15:9
8	14110	SMÖRJNIPPEL, 45°				OBEH.	14:3
8	14111	SMÖRJNIPPEL, 45°				FZB	14:3
9	14120	SMÖRJNIPPEL, 90°				OBEH.	14:3
9	14121	SMÖRJNIPPEL, 90°				FZB	14:3
7	14100	SMÖRJNIPPEL, RAK				OBEH.	14:3
7	14101	SMÖRJNIPPEL, RAK				FZB	14:3
1	14000	SP, SAXPINNE	94	1234		OBEH.	14:1
1	14000	SP, SAXPINNE	94	1234	A2		14:41
1	14001	SP, SAXPINNE	94	1234		FZB	14:1
1	14001	SP, SAXPINNE	94	1234	A4		14:42
10	6280	SP, SVETSPINNBULT			5.8	OBEH.	6:13
18	5250	SPB, SPÄNNBRICKA	6796			OBEH.	5:4
18	5250	SPB, SPÄNNBRICKA	6796		A2		5:42
18	5251	SPB, SPÄNNBRICKA	6796			MFZG	5:4
18	5251	SPB, SPÄNNBRICKA	6796		A4		5:42
39	3315	SPEEDNUTS		FST		OBEH.	3:29
39	3316	SPEEDNUTS		FST		FZB	3:29
18	15420	SPIKPLUGG, FÖRSÄNKT					15:7
17	15410	SPIKPLUGG, KULLRIG					15:7
11	15135	SPS, SPÅNSKIVESKRUV m. 4 NIBB				FZB	15:4
25	14500	SPÄNNMUTTER	1479			OBEH.	14:13
25	14501	SPÄNNMUTTER	1479			FZB	14:13
25	14502	SPÄNNMUTTER	1479			FZV	14:13
	12051	SR, KLÄMRING					12:4
5	12040	SR, STÄLLRING m. STOPPSKRUV	705				12:4
5	12040	SR, STÄLLRING m. STOPPSKRUV	705		A2		12:42
6	12050	SR, STÄLLRING m. STOPPSKRUV					12:4
7	5040	SRA, SPÄNNRING, AXEL				OBEH.	5:7
1	4032	SRB, PLANBRICKA	126	7091	HV140	OBEH.	4:2
1	4033	SRB, PLANBRICKA	126	7091	HV140	FZB	4:2
1	4034	SRB, PLANBRICKA	126	7091	HV140	FZV	4:2
1	4016	SRB, PLANBRICKA, SMS 71				OBEH.	4:4
1	4017	SRB, PLANBRICKA, SMS 71				FZB	4:4
1	4018	SRB, PLANBRICKA, SMS 71				FZV	4:4
2	4035	SRKB, KAROSSERIBRICKA				OBEH.	4:4
2	4036	SRKB, KAROSSERIBRICKA				FZB	4:4
31	10310	SS, SKENSKRUV				OBEH.	10:30
31	10311	SS, SKENSKRUV				FZB	10:30
17	7180	SSS, SPETSIG m. SPÅR	553	7434		OBEH.	7:14
17	7180	SSS, SPETSIG m. SPÅR	553	7434	A1		7:54
17	7180	SSS, SPETSIG m. SPÅR	553	7434			7:65
17	7181	SSS, SPETSIG m. SPÅR	553	7434		FZB	7:14
17	7181	SSS, SPETSIG m. SPÅR	553	7434	A4		7:54
14	2150	STAR-NYCKEL				OBEH.	2:32
14	2151	STAR-NYCKEL				FZB	2:32
13	17032	STGIK, SPLITTRÄGÄNGINSATS, KORT					16:6
15	17036	STGIL, SPLITTRÄGÄNGINSATS, LÅNG					16:6
14	17034	STGIM, SPLITTRÄGÄNGINSATS, MEDEL					16:6
10	13310	STKBL-AL/ST	ALU		STÅL		13:26
21	2050	STOPPSKRUV ESLOK, PLAN	913	4026		OBEH.	2:53
21	2056	STOPPSKRUV ESLOK, SKÅL	916	4029		OBEH.	2:53
21	2052	STOPPSKRUV ESLOK, SPETS	914	4027		OBEH.	2:53
21	2054	STOPPSKRUV ESLOK, TAPP	915	4028		OBEH.	2:53
32	10320	SUHS, UPPHÄNGNINGSSKRUV, SMAL				OBEH.	10:31

SWEBOLT AB

TEL. 08-584 909 60 FAX. 08-583 581 82

BILD	ART.GR.	BENÄMNING	DIN	ISO	KVAL	YTBEH	SIDA
32	10321	SUHS, UPPHÄNGNINGSSKRUV, SMAL				FZB	10:31
13	5075	SW, SPÄNNRING, HÅL				OBEH.	5:9
13	5176	SW, SPÄNNRING, HÅL				FZB	5:9
14	3215	SVM4M, SVETSMUTTER 4-KANT	928			OBEH.	3:11
15	3216	SVM6M, SVETSMUTTER	929		A2		3:41
15	3217	SVM6M, SVETSMUTTER	929		A4		3:41
15	3216	SVM6M, SVETSMUTTER 6-KANT	929			OBEH.	3:11
20	7210	SXH, SPÅRSKRUV m. KRYSSHÅL	404			OBEH.	7:20
20	7211	SXH, SPÅRSKRUV m. KRYSSHÅL	404			FZB	7:20
46	10610	SÖ, SKRUVÖGLA				OBEH.	10:6
46	10610	SÖ, SKRUVÖGLA			A2		10:46
46	10611	SÖ, SKRUVÖGLA				FZB	10:6
46	10611	SÖ, SKRUVÖGLA			A4		10:46
47	10615	SÖT, SKRUVÖGLA, TREKANT				OBEH.	10:37
47	10616	SÖT, SKRUVÖGLA, TREKANT				FZB	10:37
22	10150	T4SS, STÄLLSKRUV	479		8.8	OBEH.	10:21
22	10152	T4SS, STÄLLSKRUV	479		10.9	OBEH.	10:21
4	9020	T6S, 6-KANT TRÄSKRUV	571			OBEH.	9:1
4	9020	T6S, 6-KANT TRÄSKRUV	571		A2		9:40
4	9021	T6S, 6-KANT TRÄSKRUV	571			FZB	9:1
4	9021	T6S, 6-KANT TRÄSKRUV	571		A4		9:40
4	9022	T6S, 6-KANT TRÄSKRUV	571			FZV	9:1
5	9101	T6SF, 6-KANT m. FLÄNS				FZB	9:1
5	9102	T6SF, 6-KANT m. FLÄNS				FZV	9:1
10	2100	T6SS, STOPPSKRUV m. TAPP	915	4028	45HRC	OBEH.	2:28
10	2100	T6SS, STOPPSKRUV m. TAPP	915	4028	A2		2:73
10	2101	T6SS, STOPPSKRUV m. TAPP	915	4028	45HRC	FZB	2:30
10	2101	T6SS, STOPPSKRUV m. TAPP	915	4028	A4		2:74
19	10120	T6SS, STÄLLSKRUV, 6-KANT, TAPP	561B		8.8	OBEH.	10:20
27	7280	TAPPSKRUV	927			OBEH.	7:18
45	10600	TB, T-SPÅRSBULT	787			FZB	10:36
1	4300	TB, TUNN BRICKA				FÖRNICKLAD	4:61
39	4400	TB, TÄTNINGSBRICKA				SVART	4:95
39	4401	TB, TÄTNINGSBRICKA				NATUR	4:95
39	4402	TB, TÄTNINGSBRICKA				RÖD	4:95
39	4403	TB, TÄTNINGSBRICKA				GRÖN	4:95
37	4410	TB, TÄTNINGSBRICKA				SVART	4:95
1	4080	TBR, TÄTNINGSBRICKA	7603				4:71
1	4080	TBR, TÄTNINGSBRICKA	7603				4:81
4	4020	TBRB, TJOCK FASAD BRICKA				OBEH.	4:7
4	4020	TBRB, TJOCK FASAD BRICKA			A2		4:45
4	4021	TBRB, TJOCK FASAD BRICKA				FZB	4:7
4	4021	TBRB, TJOCK FASAD BRICKA			A4		4:45
4	4022	TBRB, TJOCK FASAD BRICKA				FZV	4:7
40	4450	TBRP, TÄTNINGSBRICKA RÖRPROPP				SVART	4:96
40	4451	TBRP, TÄTNINGSBRICKA RÖRPROPP				NATUR	4:96
40	4452	TBRP, TÄTNINGSBRICKA RÖRPROPP				RÖD	4:96
40	4453	TBRP, TÄTNINGSBRICKA RÖRPROPP				GRÖN	4:96
40	4454	TBRP, TÄTNINGSBRICKA RÖRPROPP				BEIGE	4:96
5	4025	TBRSB, TJOCK FASAD STOR BRICKA				OBEH.	4:7
5	4025	TBRSB, TJOCK FASAD STOR BRICKA			A2		4:45
5	4026	TBRSB, TJOCK FASAD STOR BRICKA				FZB	4:7
5	4026	TBRSB, TJOCK FASAD STOR BRICKA			A4		4:45
5	4027	TBRSB, TJOCK FASAD STOR BRICKA				FZV	4:7
18	5200	TF, TALLRIKSFJÄDER	2093 A, B, C			OBEH.	5:3
14	13550	TFBL-AL/ST	ALU		STÅL		13:51
14	13551	TFBL-KO/ST	KOPPAR		STÅL		13:52

SWEBOLT AB

TEL. 08-584 909 60 FAX. 08-583 581 82

BILD	ART.GR.	BENÄMNING	DIN	ISO	KVAL	YTBEH	SIDA
2	9005	TFS, FÖRSÄNK	97			OBEH.	9:6
2	9005	TFS, FÖRSÄNK	97		A2		9:53
2	9005	TFS, FÖRSÄNK	97				9:60
2	9006	TFS, FÖRSÄNK	97			FZB	9:6
2	9006	TFS, FÖRSÄNK	97		A4		9:54
2	9006	TFS, FÖRSÄNK	97			FÖRNICKLAD	9:60
22	9371	TFTD-S, FÖRSÄNK, SPAX, STAR				FZB	9:8
7	9030	TFX, FÖRSÄNK, POZI	7997		A2		9:55
7	9030	TFX, FÖRSÄNK, POZI	7997				9:61
7	9031	TFX, FÖRSÄNK, POZI	7997			FZB	9:9
7	9031	TFX, FÖRSÄNK, POZI	7997		A4		9:56
7	9031	TFX, FÖRSÄNK, POZI	7997			FÖRNICKLAD	9:61
13	9324	TFXD-S,				FZB	9:8
57	8406	T-FXS, FÖR TERMOPLAST, FÖRSÄNK				FZB	8:22
13	9325	TFX-S, FÖRSÄNK, SPAX, POZI				FZB	9:7
1	12000	TK, TVÄR KIL	6885B				12:2
1	12000	TK, TVÄRKIL	6885B		A4		12:40
10	13291	TKBL-AL/AL	ALU		ALU		13:27
10	13292	TKBL-AL/RF	ALU		ROSTFRI		13:28
10	13290	TKBL-AL/ST	ALU		STÅL		13:26
10	13302	TKBL-AL/ST, SVART	ALU		STÅL	5010	13:33
10	13301	TKBL-AL/ST, VIT	ALU		STÅL	9010	13:33
10	13296	TKBLG-AL/ST, m. GUMMIBRICKA	ALU		STÅL		13:32
10	13293	TKBL-KO/ST	KOPPAR		STÅL		13:29
10	13295	TKBL-RF/RF	ROSTFRI		ROSTFRI		13:31
10	13294	TKBL-ST/ST	STÅL		STÅL		13:30
3	9010	TKFS, KULLERFÖRSÄNK	95			OBEH.	9:6
3	9010	TKFS, KULLERFÖRSÄNK	95		A2		9:53
3	9011	TKFS, KULLERFÖRSÄNK	95			FZB	9:6
3	9011	TKFS, KULLERFÖRSÄNK	95		A4		9:54
3	9011	TKFS, KULLERFÖRSÄNK	95				9:60
3	9012	TKFS, KULLERFÖRSÄNK	95			FÖRNICKLAD	9:60
61	8426	T-KFTS, FÖR TERMOPLAST, KULLERFÖRSÄNK, STAR				FZB	8:23
24	9373	TKFT-S, KULLERF., SPAX, STAR				FZB	9:12
8	9035	TKFX, KULLERFÖRSÄNK, POZI	7995		A2		9:55
8	9035	TKFX, KULLERFÖRSÄNK, POZI	7995				9:61
8	9036	TKFX, KULLERFÖRSÄNK, POZI	7995			FZB	9:9
8	9036	TKFX, KULLERFÖRSÄNK, POZI	7995		A4		9:56
8	9036	TKFX, KULLERFÖRSÄNK, POZI	7995			FÖRNICKLAD	9:61
15	9328	TKFX-S, KULLERFÖRS, SPAX, POZI				FÖRN.	9:7
15	9327	TKFX-S, KULLERFÖRS., SPAX, POZI				FZB	9:7
1	9000	TKS, KULLRIG SKALLE	96			OBEH.	9:6
1	9000	TKS, KULLRIG SKALLE	96		A2		9:53
1	9000	TKS, KULLRIG SKALLE	96				9:60
1	9001	TKS, KULLRIG SKALLE	96			FZB	9:6
1	9001	TKS, KULLRIG SKALLE	96		A4		9:54
1	9001	TKS, KULLRIG SKALLE	96			FÖRNICKLND	9:60
23	9372	TKT-S, KULLRIG, SPAX, STAR				FZB	9:12
14	9326	TKX-S, KULLRIG, SPAX, POZI				FZB	9:7
40	3320	TM, T-SPÅRMUTTER	508			OBEH.	3:24
40	3321	TM, T-SPÅRMUTTER	508			FZB	3:24
59	8416	T-M6S, FÖR TERMOPLAST, SEXKANT				FZB	8:23
58	8411	T-MCS, FÖR TERMOPLAST, CYLINDRISK				FZB	8:22
	6155	TR6M, TRAPETSMUTTER, 6-KANT				OBEH.	6:4
2	4250	TRB, FÖR TRÄKONSTR.	440R			OBEH.	4:17
2	4251	TRB, FÖR TRÄKONSTR.	440R			FZB	4:17
20	5320	TRG, TÄTNINGSRING STÅL/GUMMI			FZG	5:11	
4	6075	TRHGS, HELGÄNGAD STÅNG	TRAPETSGÄNGA		5.8	OBEH.	6:4
8	6150	TRM, TRAPETSMUTTER, RUND				OBEH.	6:4
8	6160	TRM, TRAPETSMUTTER, RUND				BRONS Cu4	6:4

SWEBOLT AB

TEL. 08-584 909 60 FAX. 08-583 581 82

BILD	ART.GR.	BENÄMNING	DIN	ISO	KVAL	YTBEH	SIDA
60	8421	T-RTS, FÖR TERMOPLAST, KULLRIG, STAR				FZB	8:11
6	9025	TRX, KULLRIG, POZI	7996		A2		9:55
6	9025	TRX, KULLRIG, POZI	7996				9:61
6	9026	TRX, KULLRIG, POZI	7996			FZB	9:9
6	9026	TRX, KULLRIG, POZI	7996		A4		9:56
6	9026	TRX, KULLRIG, POZI	7996			FÖRNICKLAD	9:61
56	8401	T-RXS, FÖR TERMOPLAST, KULLRIG				FZB	8:11
62	8431	T-RXSF, FÖR TERMOPLAST, KULLRIG, FLÄNS, STAR				FZB	8:11
18	7190	TSS, TAPP m. SPÅR	417	7435		OBEH.	7:14
18	7190	TSS, TAPP m. SPÅR	417	7435	A2		7:55
18	7191	TSS, TAPP m. SPÅR	417	7435	A4		7:55
18	7191	TSS, TAPP m.SPÅR	417	7435		FZB	7:14
	13958	TÅNG FÖR BLINDNITMUTTER, TR 100					13:94
	13958	TÅNG FÖR BLINDNITMUTTER, TR 200					13:95
	13958	TÅNG FÖR BLINDNITMUTTER, TR 300					13:96
31	5352	TÅNG, BÖJD, FÖR LÅSRINGAR					5:70
32	5353	TÅNG, BÖJD, FÖR LÅSRINGAR					5:70
29	5350	TÅNG, RAK, FÖR LÅSRINGAR					5:70
30	5351	TÅNG, RAK, FÖR LÅSRINGAR					5:70
41	4608	TÄTNINGSRING, DUBBELSIDIG					4:96
1	3050	U6M, SEXKANTM,UTTER	UNC		A2		3:49
1	3050	U6M, SEXKANTMUTTER	UNC		8	OBEH.	3:31
1	3051	U6M, SEXKANTMUTTER	UNC		8	FZB	3:31
1	3051	U6M, SEXKANTMUTTER	UNC		A4		3:49
1	3052	U6M, SEXKANTMUTTER	UNC		8	FZV	3:31
18	3238	U6MH, SKARVMUTTER	UNC			OBEH.	3:34
18	3239	U6MH, SKARVMUTTER	UNC			FZB	3:34
3-4	1155	U6S, 6-KANT	UNC		A2		1:77
3-4	1156	U6S, 6-KANT	UNC		A4		1:77
3-4	1155	U6S, UNC-GÄNGA	B 18.2.1		8.8	OBEH.	1:59
3-4	1156	U6S, UNC-GÄNGA	B 18.2.1		8.8	FZB	1:60
3-4	1157	U6S, UNC-GÄNGA	B 18.2.1		8.8	FZV	1:61
3-4	1158	U6S, UNC-GÄNGA	B 18.2.1		10.9	OBEH.	1:62
7	4122	UB14, U-BALKSBRICKA, 14 %	435			FZV	4:11
7	4120	UB14, U-BALKSBRICKA, 14%	435			OBEH.	4:11
7	4120	UB14, U-BALKSBRICKA, 14%	435		A2		4:47
7	4121	UB14, U-BALKSBRICKA, 14%	435			FZB	4:11
7	4121	UB14, U-BALKSBRICKA, 14%	435		A4		4:47
7	4115	UBB, U-BALKSBRICKA, 8%	434			OBEH.	4:11
7	4115	UBB, U-BALKSBRICKA, 8%	434		A2		4:47
7	4116	UBB, U-BALKSBRICKA, 8%	434			FZB	4:11
7	4116	UBB, U-BALKSBRICKA, 8%	434		A4		4:47
7	4117	UBB, U-BALKSBRICKA, 8%	434			FZV	4:11
9	5055	UC, U-CLIPS, AXEL				OBEH.	5:7
9	5056	UC, U-CLIPS, AXEL				FZB	5:7
1-2	2010	UC6S, INSEXSRUV	UNC		A2		2:78
1-2	2011	UC6S, INSEXSRUV	UNC		A4		2:79
1-2	2018	UC6S, INSEXSRUV SERIE 1936	UNC		12.9	OBEH.	2:44
2	2016	UC6S, INSEXSRUV, SERIE 1960	UNC		8.8	FZB	2:43
2	2017	UC6S, INSEXSRUV, SERIE 1960	UNC		12.9	OBEH.	2:44
3	1120	UDDA LÄNGDER HELG.		4017	8.8	OBEH.	1:1-2
3	1120	UDDA LÄNGDER HELG.		4017	A2		1:71
3	1121	UDDA LÄNGDER HELG.		4017	8.8	FZB	1:5-6
3	1121	UDDA LÄNGDER HELG.		4017	A4		1:75
3	1122	UDDA LÄNGDER HELG.		4017	8.8	FZV	1:9
3	1122	UDDA LÄNGDER HELG.		4017	A4-80		1:73
3	1123	UDDA LÄNGDER HELG.	933		8.8	OBEH.	1:5-6
3	1123	UDDA LÄNGDER HELG.	933		A2		1:71
3	1124	UDDA LÄNGDER HELG.	933		8.8	FZB	1:7-8
3	1124	UDDA LÄNGDER HELG.	933		A4		1:75

SWEBOLT AB

TEL. 08-584 909 60 FAX. 08-583 581 82

BILD	ART.GR.	BENÄMNING	DIN	ISO	KVAL	YTBEH	SIDA
3	1125	UDDA LÄNGDER HELG.	933		8.8	FZV	1:9
3	1125	UDDA LÄNGDER HELG.	933		A4-80		1:73
4	1128	UDDA LÄNGDER, HELG.	933		10.9	OBEH.	1:11-12
4	1129	UDDA LÄNGDER, HELG.	933		10.9	FZB	1:15-16
4	1132	UDDA LÄNGDER, HELG.		4017	10.9	OBEH.	1:11-12
4	1133	UDDA LÄNGDER, HELG.		4017	10.9	FZB	1:15-16
3	2035	UF6S, FÖRSÄNKAT INSEXSKRUV	UNC		10.9	OBEH.	2:46
2	7015	UFS, FÖRSÄNKAT	UNC		4.8	FZB	7:21
2	7015	UFS, FÖRSÄNKAT	UNC		A4		7:56
19	9340	UFT, FÖRSÄNKAT, STAR			A2		9:47
19	9341	UFT, FÖRSÄNKAT, STAR				FZB	9:5
19	9341	UFT, FÖRSÄNKAT, STAR			A4		9:48
16	9311	UFX, FÖRSÄNKAT, POZI				FZB	9:3
16	9311	UFX, FÖRSÄNKAT, POZI			A2		9:41
16	9312	UFX, FÖRSÄNKAT, POZI			A4		9:42
6	11050	UGKP, GÅNG KONISK PINNE	UNC				11:14
3	6060	UHGS, HELGÅNGAD STÅNG	UNC		4.6	OBEH.	6:1
3	6060	UHGS, HELGÅNGAD STÅNG	UNC		A2		6:40
3	6061	UHGS, HELGÅNGAD STÅNG	UNC		4.6	FZB	6:1
3	6061	UHGS, HELGÅNGAD STÅNG	UNC		A4		6:40
8	3175	UHM, HATTMUTTER	UNC		6	OBEH.	3:33
8	3176	UHM, HATTMUTTER	UNC		6	FZB	3:33
5	6203	UHPS, HELGÅNGAD PINNSKRUV	UNC		4.6	OBEH.	6:22
5	6204	UHPS, HELGÅNGAD PINNSKRUV	UNC		4.6	FZB	6:22
30	10300	UHS, UPPHÄNGNINGSSKRUV			4.6	OBEH.	10:30
30	10301	UHS, UPPHÄNGNINGSSKRUV			4.6	FZB	10:30
6	2075	UK6S, KULLRIG INSEXSKRUV	UNC		10.9	OBEH.	2:48
21	9360	UKFT, KULLERFÖRSÄNKAT, STAR			A2		9:51
21	9361	UKFT, KULLERFÖRSÄNKAT, STAR				FZB	9:4
21	9361	UKFT, KULLERFÖRSÄNKAT, STAR			A4		9:52
18	9320	UKFX, KULLERFÖRSÄNKAT, POZI			A2		9:45
18	9321	UKFX, KULLERFÖRSÄNKAT, POZI				FZB	9:4
18	9321	UKFX, KULLERFÖRSÄNKAT, POZI			A4		9:46
6	3155	UKM, KRONMUTTER	UNC		8	OBEH.	3:35
6	3156	UKM, KRONMUTTER	UNC		8	FZB	3:35
20	9350	UKT, KULLRIG, STAR			A2		9:49
20	9351	UKT, KULLRIG, STAR				FZB	9:5
20	9351	UKT, KULLRIG, STAR			A4		9:50
17	9301	UKX, KULLRIG, POZI				FZB	9:2
17	9301	UKX, KULLRIG, POZI			A2		9:43
17	9302	UKX, KULLRIG, POZI			A4		9:44
2	3090	UL6M, LÅG SEXKANTMUTTER	UNC		6	OBEH.	3:31
2	3091	UL6M, LÅG SEXKANTMUTTER	UNC		6	FZB	3:31
2	3090	UL6M, LÅGMUTTER	UNC		A2		3:48
5	2066	ULC6S, LÅG INSEXSKRUV	UNC		12.9	OBEH.	2:48
1	7005	ULCS, CYL. SKALLE	UNC		4.8	FZB	7:21
1	7005	ULCS, CYL. SKALLE	UNC		A4		7:56
8	2085	UP6SS, STOPPSKRUV PLAN	UNC		45HRC	OBEH.	2:49
1	6010	UPS, PINNSKRUV, UNC	SS1948		5.8	OBEH.	6:20
1	6010	UPS, PINNSKRUV, UNC	SS1948		A2		6:48
1	6011	UPS, PINNSKRUV, UNC	SS1948		5.8	FZB	6:20
1	6011	UPS, PINNSKRUV, UNC	SS1948		A4		6:48
1	6013	UPS, PINNSKRUV, UNC	SS1948		8.8	OBEH.	6:21
1	6014	UPS, PINNSKRUV, UNC	SS1948		8.8	FZB	6:21
9	2095	US6SS, STOPPSKRUV m. SPETS	UNC		45HRC	OBEH.	2:49
20	10130	USK4SS, STÄLLSKRUV, 4-KANT				OBEH.	10:20
11	2115	USK6SS, STOPPSKRUV SKÅLAD	UNC		45HRC	OBEH.	2:49
11	2116	USK6SS, STOPPSKRUV SKÅLAD	UNC		A4		2:80
10	2105	UT6SS, STOPPSKRUV m. TAPP	UNC		45HRC	OBEH.	2:49

SWEBOLT AB

TEL. 08-584 909 60 FAX. 08-583 581 82

BILD	ART.GR.	BENÄMNING	DIN	ISO	KVAL	YTBEH	SIDA
1	10008	UVBF, VAGNSBULT	UNC	603	4.6	OBEH.	10:27
1	10009	UVBF, VAGNSBULT	UNC	603	4.6	FZB	10:27
12	3205	UVM, VINGMUTTER		UNC		OBEH.	3:34
12	3206	UVM, VINGMUTTER		UNC		FZB	3:34
3-4	1165	W6S, WITHWORTH GÄNGAD			8.8	OBEH.	1:65
13	14340	VAJERLÅS	741			FZB	14:7
13	14340	VAJERLÅS	741		A2		14:45
13	14341	VAJERLÅS	741			FZV	14:7
29	14524	VANTSKRUV m. HAKAR	1480				14:15
26	14521	VANTSKRUV m. PINNBULT	1480				14:14
27	14522	VANTSKRUV m. ÖGELBULT	1480				14:14
28	14523	VANTSKRUV m. ÖGLA+HAKE	1480				14:15
26	14520	VANTSKRUV, HYLSA	1480				14:14
22	5340	VB, VÅGBRICKA				OBEH.	5:13
16	15561	VENTB, m. FLÄNS, MEJSELSPÅR, BORRSPETS				FZB	15:6
15	15560	VENTS, m. FLÄNS, MEJSELSPÅR				FZB	15:6
22	3291	VERBUS RIPP			10	FZB	3:30
3	2040	WF6S, FÖRSÄNKT INSEXSKRUV	WITHW+BSF		10.9	OBEH.	2:46
1	3037	VFM6M, FING., VÄNSTERG.	934		8	OBEH.	3:18
1	3038	VFM6M, FING., VÄNSTERG.	934		8	FZB	3:18
1	3039	VFM6M, FING., VÄNSTERG.	970	4032	8	OBEH.	3:18
7	6130	VHM6M, VARMHÅLLF. MUTTER	2510NF	24CrMo5		OBEH.	6:5
7	10045	VHSS, VÅGHYVELSKRUV			8.8	OBEH.	10:14
31	8090	WING-TEKS				FZB	8:7
12	9070	VK, VINKELKROK, TRÄGÄNGA				OBEH.	9:11
12	9071	VK, VINKELKROK, TRÄGÄNGA				FZB	9:11
3	12020	WK, WOODRUFFKIL	6888				12:2
12	9073	VKK, VINKELKROK, KRAFTIG, TRÄGÄNGA				FZB	9:11
48	10620	VKM, VINKELKROK				OBEH.	10:37
48	10621	VKM, VINKELKROK				FZB	10:37
12	3200	VM, VINGMUTTER	315				3:91
12	3200	VM, VINGMUTTER ADDUC	315			OBEH.	3:51
12	3201	VM, VINGMUTTER ADDUC	315			FÖRNICKLAD	3:51
1	3022	VM6M, VÄNSTERGÄNGA	934		8	OBEH.	3:2
1	3023	VM6M, VÄNSTERGÄNGA	934		8	FZB	3:2
1	3026	VM6M, VÄNSTERGÄNGA 0,8d	934		10	OBEH.	3:18
1	3024	VM6M, VÄNSTERGÄNGA 0,9d	970	4032	8	OBEH.	3:18
1	3025	VM6M, VÄNSTERGÄNGA 0,9d	970	4032	8	FZB	3:18
13	3202	VM-A, VINGMUTTER AM-TYP				OBEH.	3:10
13	3203	VM-A, VINGMUTTER AM-TYP				FZB	3:10
13	3200	VM-A, VINGMUTTER, AM-TYP			A2		3:41
13	3201	VM-A, VINGMUTTER, AM-TYP			A4		3:41
3	6090	VMHGS, VÄNSTERGÄNGA			8.8	OBEH.	6:3
2	3070	VML6M, LÅG, VÄNSTERG.	936/439B	4035	6	OBEH.	3:5
2	3071	VML6M, LÅG, VÄNSTERG.	936/439B	4035	6	FZB	3:5
28	10220	VS, VINGSKRUV	316			OBEH.	10:5
28	10220	VS, VINGSKRUV	316				10:62
28	10220	VS, VINGSKRUV	316				10:70
28	10221	VS, VINGSKRUV	316			FZB	10:5
28	10221	VS, VINGSKRUV	316			FÖRNICKLAD	10:62
28	10220	VS, VINGSKRUV, AM-TYP	316		A2		10:44
28	10221	VS, VINGSKRUV, AM-TYP	316		A4		10:44
6	10040	VÄGRÄCKESSKRUV			4.6	FZV	10:14
10	9050	ÖST, ÖGLESKRUV, TRÄGÄNGA				OBEH.	9:10
10	9050	ÖST, ÖGLESKRUV, TRÄGÄNGA			A2		9:57
10	9050	ÖST, ÖGLESKRUV, TRÄGÄNGA					9:62
10	9051	ÖST, ÖGLESKRUV, TRÄGÄNGA				FZB	9:10

SWEBOLT AB

TEL. 08-584 909 60 FAX. 08-583 581 82